

Control Material Flow and Purge Lines

The Adjustable Purge Valve (APV) controls material flow from a hopper or surge bin, and is ideal for use with central drying and conveying systems.

Designed for flange-mount applications, the APV releases material into the conveying lines as needed, and then purges the material lines to prevent material cross-contamination and/or moisture regain.

The APV can be used in either dry or ambient air conveying applications.



Model APV

Automatically Purges Conveying Line With Air

The Adjustable Purge Valve will remain open for a specified amount of time (set by the user in the central loading control) during the vacuum conveying cycle to allow material to flow through the valve.

While vacuum is still present, the material valve closes and the material flow stops. The flow of air continues through the valve and material line, fully purging the valve and material line.

The valve conveniently bolts to the bottom of the material hopper discharge. Unlike alternative models, a separate distribution box is not required.

The APV can be used with FLX-128 Plus and ELC Loading Controls when used to convey from a single source to a single destination. However, when conveying from multiple sources to multiple destinations, the FLX-128 Plus must be used.

For inline mounting applications, refer to the Purge Valve specification sheet.

- ▶ **Design ensures complete purging**
This valve design ensures positive material shut off and successfully evacuates all material from the valve during purging.
- ▶ **Flexible installation**
Equipped with a 360° swiveling material outlet which allows quick placement of equipment during installation.
- ▶ **Modular components; easy maintenance**
Bolt-on components allow common wear parts to be easily maintained without the need for removing the entire valve.
- ▶ **Smooth, aluminum body**
A non-corrosive, aluminum body provides a smooth path for material and air to flow. All other valve components are made of stainless steel.
- ▶ **Easy and safe to clean**
Removable with no tools, the cleanout door provides wide open access.
- ▶ **Dual-pump systems; one material source**
Purge material conveying lines that are served by separate vacuum pumps with the Dual Outlet Adjustable Purge Valve.
- ▶ **High-wear plating is available as an option**



How it Works

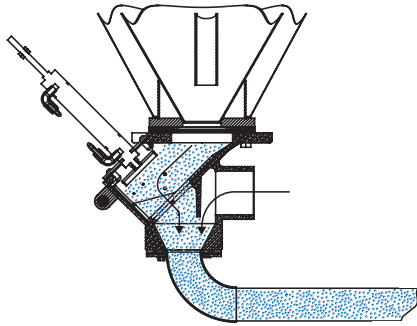

The opening of the valve during loading cycle.

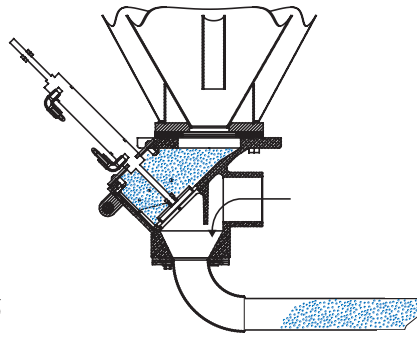

The closing of the valve during the purging cycle.

Material conveying

When a signal from the loading system is received, the solenoid valve on the APV will engage the dispensing valve. The dispensing valve will open to a pre-determined level and allow the hopper material to flow down to the lower portion of the APV, which is under high velocity air from the dryer's vacuum system. The high velocity air will then transport the hopper material to its destination. This is the load time.

Purging

After a period of time, (the loading time is set by the user at the central loading control) the dispensing valve will close causing the material flow to stop. The loading system will continue to flow through the valve, clean the valve and completely convey the hopper material to its destination. This is referred to as purge time.

Application



Both the Single and Dual Outlet Adjustable Purge Valve (APV) convey and completely purge material lines resulting in contamination-free processing. Use the Single Outlet APV when only one (1) vacuum pump is used. In applications where two (2) vacuum pumps are required to convey material from a single material source, the Dual Outlet APV is ideal. A "Y" diverter casting in addition to two (2) APVs comprises the dual outlet assembly. **NOTE:** An optional straight outlet tube is available for gravity flow applications.

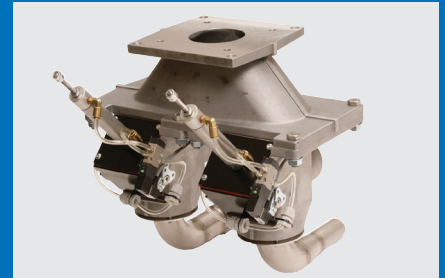

Accessories

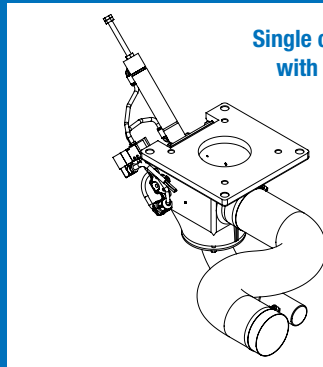

Single outlet APV with dry air kit

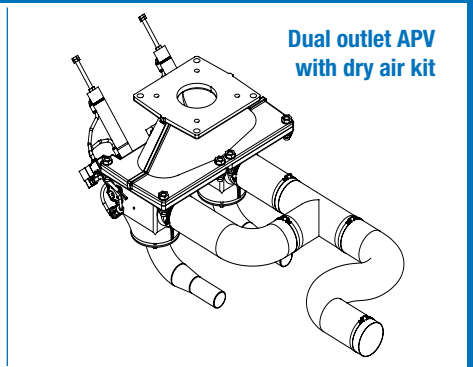

Dual outlet APV with dry air kit

Dry air conveying kit

The dry air conveying kit provides low dewpoint air to the air inlet of the APV and is recommended for applications where dried material is being conveyed and moisture regain is a concern. (Pictured here is the Dual Outlet APV with the Dry Air Conveying Kit attached.)

Specifications

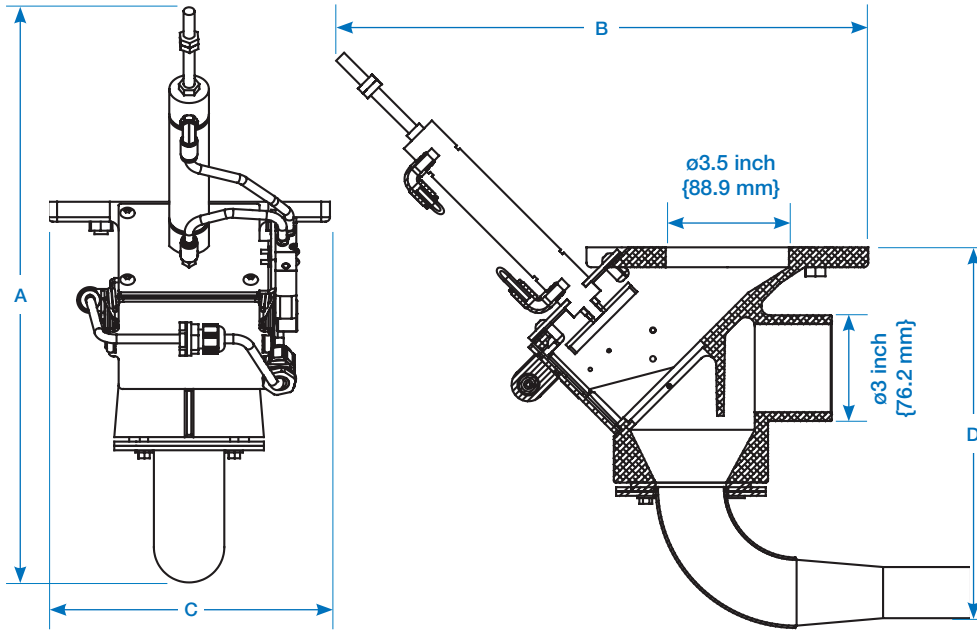

Specification Notes

- * Throughputs will depend upon pump size, material line size and conveying distances.
 - † Overall height will vary slightly due to line size.
 - ‡ The height under the hopper may vary by up to 1.5 inches (38.1 mm) depending on the material tube size. Material tube sizes change based on line size and on the amount of material being conveyed. An optional straight tube outlet is available for gravity flow.
- Specifications may change without notice. Consult with a Conair representative for the most current information.

Model	APV	
Performance characteristics* inches {mm}		
Material inlet size diameter	3.5 {88.9}	
Purge air inlet	3.0 {76.2}	
Type of inlet/outlet connection	bolt-on	
Body type aluminum	cast	
Dimensions inches {mm}		
A - Overall height †	16.3 {414.0}	
B - Depth	15.1 {383.5}	
C - Width	8.0 {203.2}	
D - Height under the hopper ‡	Discharge line OD	Height under the hopper
	1.5 {38.1}	10.8 {274.3}
	1.75 {44.5}	10.8 {274.3}
	2.0 {50.8}	10.8 {274.3}
	2.25 {57.2}	10.9 {277.6}
	2.5 {63.5}	11.8 {299.7}
	3.0 {76.2}	12.1 {306.0}
Weight lb {kg}		
Installed	12.0 {5.4}	
Shipping	22.0 {9.9}	
Electrical compatibility		
Available voltage	24 VAC, 24 VDC, 120 VAC	
Compressed air requirement		
0.1 ft ³ /min {3 l/min} @ minimum of 60 psi {4.1 bar} maximum of 100 psi {6.9 bar}; 1/4 NPT male fitting.		

Mounting Interface

- IB02 for 5 x 5 inch bolt pattern
- IB03 for 7 x 7 inch bolt pattern

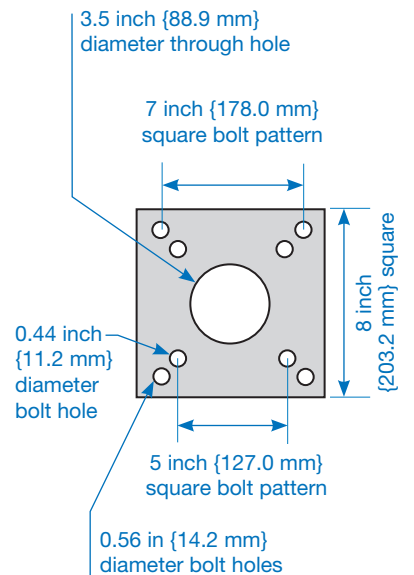

Specifications

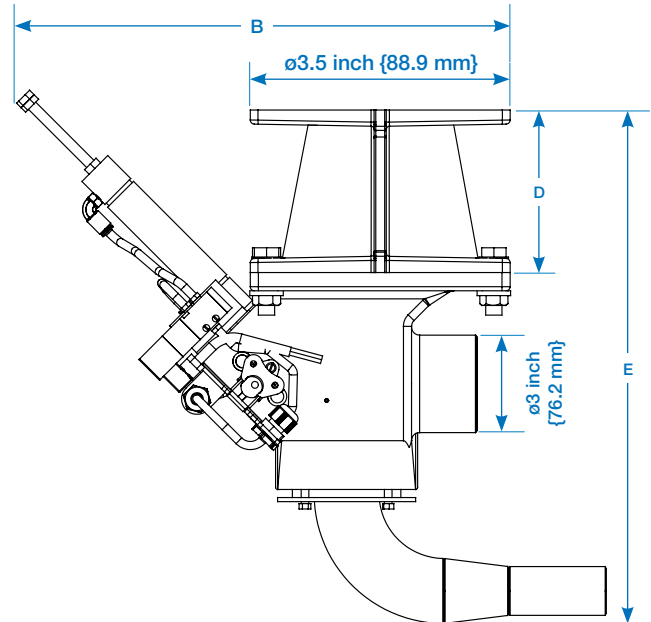
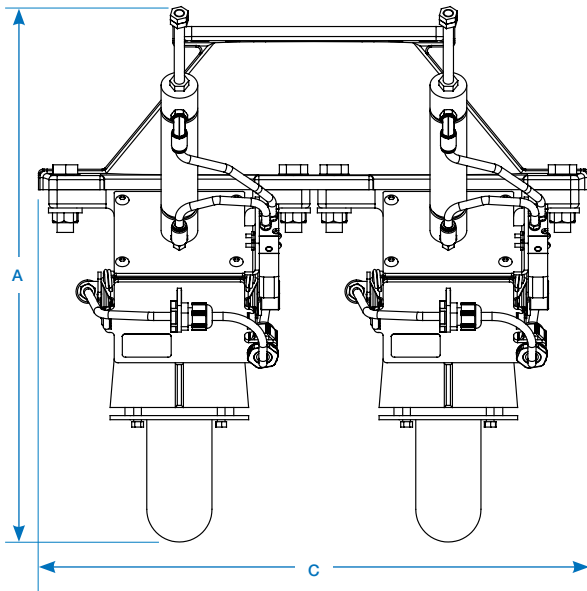

Model	Dual Outlet APV	
Performance characteristics*	inches {mm}	
Material inlet size diameter	3.5 {88.9}	
Purge air inlet	3.0 {76.2}	
Type of inlet/outlet connection	bolt-on	
Body type aluminum	cast	
Dimensions	inches {mm}	
A - Overall height†	16.3 {414.0}	
B - Depth	15.1 {383.5}	
C - Width	16.9 {429.3}	
D - Adapter plate height	5.0 {127.0}	
E - Height under the hopper‡	Discharge line OD	Height under the hopper
	1.5 {38.1}	15.8 {401.3}
	1.75 {44.5}	15.8 {401.3}
	2.0 {50.8}	15.8 {401.3}
	2.25 {57.2}	15.9 {403.9}
	2.5 {63.5}	16.8 {426.7}
	3.0 {76.2}	17.1 {434.3}
Weight	lb {kg}	
Installed	45.0 {20.5}	
Shipping	55.0 {24.9}	
Electrical compatibility		
Available voltage	24 VAC, 24 VDC, 120 VAC	
Compressed air requirement		
0.2 ft ³ /min {5.6 l/min} @ minimum of 60 psi {4.1 bar} maximum of 100 psi {6.9 bar}; two (2) 1/4 NPT male fittings.		

Mounting Interface

IB02 for 5 x 5 inch bolt pattern

IB03 for 7 x 7 inch bolt pattern

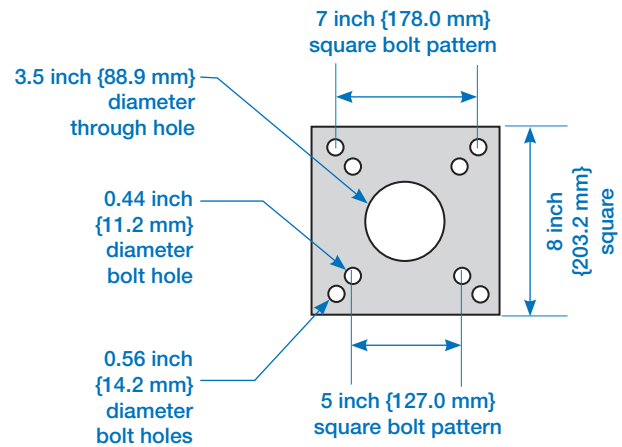

Specification Notes

* Throughputs will depend upon pump size, material line size and conveying distances.

† Overall height will vary slightly due to line size.

‡ The height under the hopper may vary by up to 1.5 inches {38.1 mm} depending on the material tube size. Material tube sizes change based on line size and on the amount of material being conveyed. An optional straight tube outlet is available for gravity flow.

Specifications may change without notice. Consult with a Conair representative for the most current information.

