

Touch Controlled Machine-side Drying

Conair Carousel Plus™ dehumidifying dryers guarantee moisture removal from resins, regardless of moisture content. You can be assured your molded or extruded products will be unaffected by moisture content that can jeopardize their quality.

Equipped with highly efficient desiccant wheels, long-life tube heaters and powerful blowers, Conair D Series Dryers can be coupled with a single hopper for efficient resin drying up to 400 lbs/hr {181.4 kg/hr} or more (see chart, next page).

These D Series Dryers, models 150 through 400 offer a choice of full-color, high-resolution touchscreen controls, for the simplest, yet most sophisticated control over the drying of your valuable resin.



Model D150
Shown with
DC-C control

Throughputs from 150 to 400 lb/hr, No Cooling Water Required

Conair Carousel Plus Dryers use molecular sieve desiccant that is bonded onto a fiberglass substrate and formed into a light, compact, continuously rotating wheel that never breaks down, while providing low-pressure, free-flow of dehumidified air.

The result is rock-steady, spike-free drying temperatures and low, consistent dewpoint levels, critical for processing engineering resins. Desiccant is efficiently regenerated at reduced temperatures, making Conair Carousel Plus Dryers the most energy efficient dryer you can buy.

With the optional air-to-air aftercooler, this dryer does not require cooling water, saving additional installation and operating costs. All Conair desiccant dryers use proven desiccant wheel technology for the most reliable dehumidification of resin possible.

dX Series, mobile drying and conveying systems are also available.

▶ **Choice of simple to use, advanced touchscreen controls**

Intuitive screen navigation will allow you to easily view critical drying parameters such as dewpoint, temperature and alarms. Choose the 4-inch DC-C Plus or 7-inch DC-C Premium for economically priced reliability in the most easy to understand, yet fully featured drying control ever produced.

▶ **Reduced energy costs, smaller footprint**

The desiccant wheel assembly heats and cools more easily than previous drying technology, saving you up to 50% on your energy bill. 90% fewer parts and 70% lighter structural mass means less to heat, and no cooling water required, therefore less wasted energy.

▶ **Maximum uptime, maximum reliability**

The D Series includes significantly fewer parts and easier access for easy maintenance, so you can expect less wear, less downtime and many years of trouble-free operation. There are no indexing desiccant beds, no complex air valves and no loose desiccant beads. The desiccant wheel is a solid, continuously rotating trouble-free desiccant module. Shift-after-shift, year after year, these dryers will deliver worry-free drying performance.

▶ **Precise, adjustable dewpoint control**

Precision dewpoint control is built into the control and allows you to easily select a desired dewpoint. The control does the rest by adjusting dryer functions to precisely deliver that drying dewpoint, day in and day out, from one resin supply to another. Never worry about over-drying or under-drying again.



How it Works

The core of the Carousel Plus Dryer is the Munters® unique fluted desiccant rotor, which is made of molecular sieve desiccant. The molecular sieve has been grown onto the rotor's porous fiberglass substrate, preventing desiccant break down and dusting over time. The desiccant rotor revolves slowly at the rate of 12 revolutions per hour, passing through three cycles with each revolution.

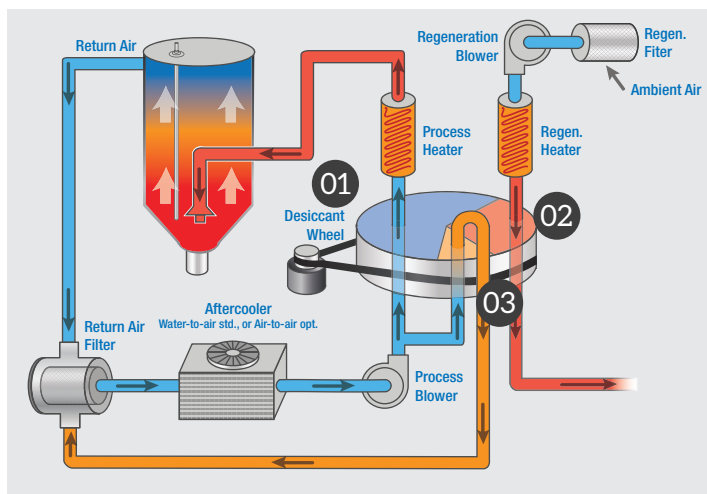

The Benefits

- The high airflow across the rotor surface area produces a resin-drying low dewpoint within 5 minutes of start-up and offers multi-year media life with virtually no maintenance.
- The continuously revolving rotor provides rock steady temperature and dewpoint control.
- The rotor technology minimizes energy consumption by reducing the structural mass. Less structural mass to heat means less energy wasted.

01

The dry air is dehumidified in the adsorption cycle, capturing and removing moisture from the drying air stream.

02

The desiccant passes into the high temperature regeneration cycle; absorbed moisture is heated and purged out of the desiccant to the atmosphere.

03

The desiccant is then advanced to the post-regeneration cooling cycle and cooled with closed loop dry air. This unique closed loop cooling technology eliminates moisture that can cause defects in parts.

Recommended Throughputs (60 Hz chart)*			For 50 Hz Application, Reduce Rates by 17%					
Material	Drying Temp / °F {°C}	Drying Time / Hr †	Initial Moisture %	Bulk Density ‡	Model Throughput Rate§ / Lb / Hr			
					D150 **	D200 **	D300 **	D400 **
ABS	180-190 {82-88}	4	0.40	40 {0.64}	150	200	300	400
Acetal	180-230 {82-110}	4	0.60	40 {0.64}	113	149	225	300
Acrylic	170-180 {77-82}	4	0.30	40 {0.64}	173	233	347	465
Nylon	160-180 {71-82}	6	0.40	40 {0.64}	162	215	323	430
PBT	210-260 {99-127}	4	0.30	45 {0.72}	168	223	335	445
PC	250 {121}	4	0.30	40 {0.64}	155	208	313	416
PE (HD/LP) w/40% black	170 {77}	5	-	26-34 {0.42-0.54}	150	200	300	400
PET virgin bottle grade	300-350 {144-177}	6	0.30	50 {0.80}	150	200	300	400
PETG	140-150 {60-66}	6	0.30	50 {0.80}	162	215	323	430
Polysulfone	200-275 {93-135}	4	0.50	50 {0.80}	92	123	185	245
Polyurethane	180-210 {82-99}	4	0.50	40 {0.64}	105	140	210	280
SAN	160-180 {71-82}	2 - 4	0.30	45 {0.72}	188	250	375	500

Select the right dryer for your application –

1. Identify the resin and throughput rate.

Use the chart to quickly select the correct dryer model for your throughput rate.

2. Multiply the suggested drying time by your throughput rate to determine the hopper size.

Refer to Conair drying hopper specifications, or contact a Conair representative to determine the correct hopper for your application.

3. Select the dryer model and options to suit your application.

Carousel Plus™ D Series models can be used for individual station drying applications.

Application Notes

* Material throughputs are based on typical virgin material with initial moisture content as supplied by the material suppliers. Consult Conair if specific initial and final moisture content of your material are known for your application.

† The parameters of drying temperature and time may vary depending upon the type, grade and manufacturer of the material being processed. Consult your material supplier for their precise recommendations.

‡ Unit of measurement for bulk density is lb/ft³ {g/cm³}. Bulk density listed is the nominal weight for typical pellets. The bulk density may vary somewhat depending upon the size and shape of the pellets. The bulk density of regrind may vary widely depending upon the size and the shape of the flake. Be sure to consider the bulk density of the material when selecting and the drying time desired.

§ Throughputs will vary by type of material. Consult Conair concerning throughputs for materials that are not listed here.

** All Conair Dryers are equipped with an aftercooler as standard. The aftercooler reduces the temperature of the return air from the drying hopper, improving the efficiency of the desiccant. If using the water-cooled aftercooler option, the aftercooler must be connected to supply water with the proper flow rate and temperature.



Choose the control you need... DC-C Plus or DC-C Premium

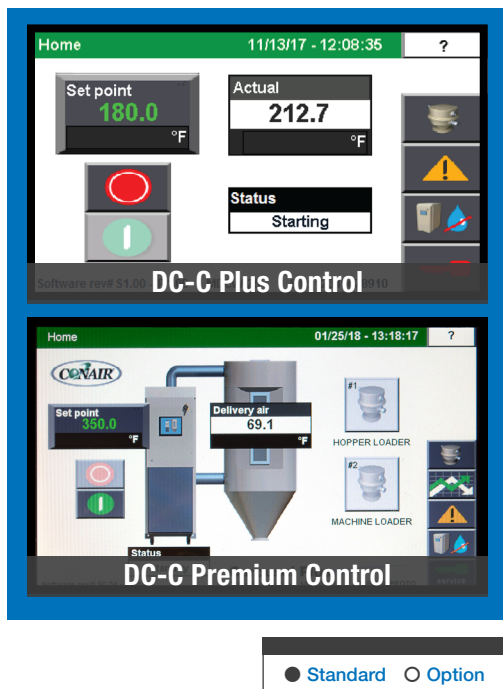

● Standard ○ Option

Control	DC-C Plus	DC-C Premium
Standard		
Processor / control type	Proprietary	Proprietary
Display / HMI screen	4-inch color	7-inch color
Trending screens (dewpoint, temperature, heater on-time)	●	●
Auto start/stop	1 day/time	7 day/time
English / metric units	●	●
Password protected	●	●
Web-enabled	●	●
Temperature Setback (manual/auto)	○	●
Dewpoint monitor and control	●	●
Energy Usage Meter	●	●
Audible and Visual alarm	●	●
VNC viewer		●
Air-to-air heat exchange	○	○
Predictive maintenance	●	●
Available options		
Drying Monitor		○
Vacuum Conveying	○	○
Number of vacuum receivers	1	2
Ratio loading		Conveying dependent
Purge		Conveying dependent
Vacuum fill		Conveying dependent
Modbus TPC Communications		○
H2O flow control		○
UL option		○
Process filter check	○	○
Water-cooled aftercooler	○	○

Feature Descriptions

- **Audible and visual alarm** - A combination of a blinking alarm light and a horn.
- **Temperature setback** - Automatically reduces the drying temperature when the machine throughput is reduced. Processors using resins prone to degradation due to over drying greatly benefit from this feature. ** Standard on DC-C Premium control, optional on DC-C Plus.*
- **Dewpoint monitor** - Monitor the performance of the dryer with a digital dewpoint readout of the drying air.
- **Dewpoint control** - Allows the dryer to maintain an operator-selected dewpoint level. This feature helps prevent overdrying of moisture sensitive materials such as nylon. Location and season changes can drastically change the atmospheric dewpoint of air. Dewpoint control is used to increase or decrease the regeneration temperature as needed depending on atmospheric conditions. This saves energy costs and increases end-product quality.
- **Optional air-to-air aftercooler** - The optional air-to-air aftercooler means no water hook-up is required for operation. An aftercooler is required to reduce the temperature of the return air from the hopper, which improves the efficiency of the desiccant. The new air-to-air cooler achieves drying efficiency at temperatures up to 375°F {191°C}, while saving water and simplifying installation.

Option Descriptions

- **Volatile Trap** - For materials that give off plasticizer residue when dried, an optional Volatile Trap is recommended to demist the volatiles from the hopper's return air and collect them prior to the air entering the desiccant. Volatile traps extend desiccant life, reduce maintenance and include a convenient drain spigot. Volatile trap requires the optional water-cooled aftercooler.
- **Precooler** - For drying temperatures below 150°F {65°C}, an optional Precooler is required to remove the internal heat of the dryer for low temperature drying. Precooler water connections match those of the standard aftercooler as listed in the specifications section.
- **Process filter check** - To conveniently monitor air flow critical for drying, the Process Filter Check option provides an alarm when the resin drying air filter is blinded, jeopardizing effective drying. Process Filter Check provides essential guidance to maintenance intervals.
- **Communications** - When connected to a network the controller on the network may read actual temperatures, change setpoints, read dryer status, and process and display this information at a central location. Ethernet communications are available on the DC-C Premium control.

- **Drying Monitor** - Save time and money from the aggravation of improperly dried material. The Drying Monitor automatically monitors the heat profile inside your drying hopper with a 6-zone temperature probe, to protect resin from over or under-drying. A control alarm and a light tower alert if proper drying is in jeopardy. Advanced notice provides time to correct issues instead of wasted drying and product defects from common issues like:
 - Failed or out-of-place process temperature probe,
 - Improperly sized hopper or dryer or unplanned change of rate,
 - Loss of power,
 - Lack of resin or loading equipment failure,
 - Reduced airflow through filters, kinked hoses or obstructions.
 Your DC-C control will alarm on most dryer-related problems, but the Drying Monitor goes further, to report proper drying happening inside the drying hopper. **Not available on the DC-C Plus control.*

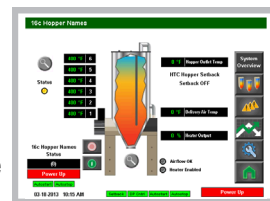

Specifications

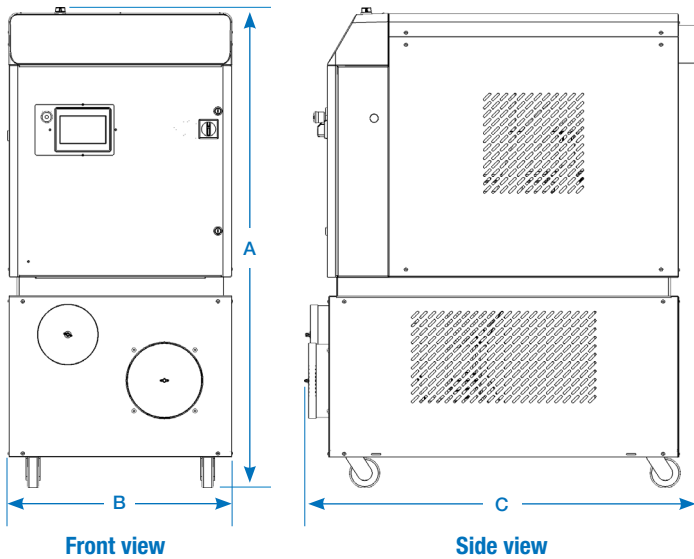

Application Notes

All dryers are supplied with an aftercooler as standard. The aftercooler reduces the temperature of the return air from the drying hopper, improving the efficiency of the desiccant. If using the water-cooled aftercooler, the aftercooler must be connected to supply water with the proper flow rate and temperature.

Central drying

Central dryers have no process heaters and are used to supply dry air to multiple drying hoppers. The central dryer, equipped with a desiccant wheel and regeneration system, supplies dehumidified air, which is heated to individual set points by the heaters and controls located at each drying hopper. These D Series dryers are not able to be used as central drying systems.

Additional filtration options

The standard return air cartridge filter is sized for the airflow of each dryer model and is suited for most applications. You should consider adding an optional dust collector and/or volatile trap if:

- The material contains excessive fines. An additional dust collector or cyclone will extend time between filter cleaning.
- The material produces volatiles during drying which condense into a waxy or oily residue. A volatile trap will help to protect the desiccant.

Models	D150	D200	D300	D400
Performance characteristics (with full hopper)				
Drying temperature *	100° - 375°F {38° - 191°C} with options			
Dewpoint	-40°F {-40°C}			
Dimensions inches {cm}				
A - Height	64.2 {163.1}			
B - Overall width	29.7 {75.3}			
C - Depth	52.6 {133.5}			
Outlet/inlet tube size OD	2.5 {63.5}		5.0 {127}	
Approximate weight lbs {kg}				
Installed	672 {305}	739 {335}	795 {361}	851 {386}
Shipping	885 {401}	1114 {505}	1170 {531}	1461 {663}
Voltage - Full load amps (standard dryer / central drying)				
230 V/3 phase/60 Hz	42.4 / 17.3	57.4 / 19.7	67.5 / 29.8	N/A
400 V/3 phase/50 Hz†	24.4 / 9.9	33.0 / 11.3	38.8 / 17.1	64.2 / 20.8
460 V/3 phase/60 Hz	21.2 / 8.6	28.7 / 9.8	33.8 / 14.9	55.8 / 18.1
575 V/3 phase/60 Hz	17.0 / 6.9	23.0 / 7.9	21.7 / 12.0	44.7 / 14.5
Water-cooled requirements (for aftercooler or precooler)*§				
Recommended temperature**	45° - 85°F {7.2° - 29.4°C}			
Water flow gal./min. {liters/min.}	3 {11.4}			
Water connections NPT	3/4 inch			

Specification Notes

* Total kW listed at a process setpoint of 250°F {121°C} and a regeneration temperature of 350°F {177°C}.

† Dryers running at 50 Hz will have 17% less airflow, and a 17% reduction in material throughput.

‡ When drying below 150°F {66°C} a precooler is required.

§ When ambient temperature is above 110°F {43°C} and drying above 375°F {191°C} a water-cooled aftercooler is required.

**Temperatures above or below the recommended levels may affect dryer performance. Tower, chiller or municipal water sources can be used.

††FLA data for reference purposes only. Does not include any options or accessories on equipment. For full FLA detail for power circuit design of specific machines and systems, refer to the electrical diagrams of the equipment order and the nameplate applied to the machine.

Specifications may change without notice. Consult a Conair representative for the most current information.

