

Mobile Cart Dryers With Conveying Control

Mobile drying and conveying systems eliminate the need for machine-mounted hoppers by placing all components on a safe, convenient cart.

Set-up, pre-drying, clean-out and maintenance can all take place without tying up valuable process machine time, or climbing on the machine.

The DC-C Control is available in two configurations. The 4-inch DC-C Plus control is perfect for standard operation: set it and forget it. For more advanced features, the 7-inch DC-C Premium offers everything you want. Regardless which control you choose, you'll be getting a simple-to-use operator station that isn't intimidating to the user. Intuitive icons, help screens, and full-color touch operation make the DC-C control a favorite.



Model dx-25

Mobile Performance Up to 100 lbs/hr, No Cooling Water Required

These Carousel Plus™ dx models are small enough to be used beside the machine.

dx units feature true closed-loop drying and conveying technology to eliminate moisture that can cause defects in parts. You can dry at temperatures up to 375°F {191°C} and at through put rates of 10 to more than 100 pounds per hour {4.3 to 45.4 kg/hr}.

The Carousel Plus Dryers use molecular sieve desiccant that is bonded into a fiberglass substrate and formed into a continuously rotating wheel. The result is rock steady drying temperatures and dewpoint levels, critical for processing moisture and temperature sensitive material.

The new optional air-to-air aftercooler is available and does not require cooling water, saving additional costs.

▶ **Simple to use, advanced touchscreen control – two options**

The DC-C control on the dx dryers makes controlling your mobile drying and conveying easier than ever. The 4-inch Plus, or 7-inch Premium touchscreen control has descriptive help screens for operators and features detailed trending screens, auto start capabilities, password protection and has Conair's Drying Monitor capabilities built into the DC-C Premium control (requires the appropriate hardware).

▶ **Closed-loop drying/conveying**

Each unit provides drying temperatures up to 375°F {191°C}, automatic desiccant regeneration and dewpoints of -40°F {-40°C}.

▶ **No-downtime material changes**

With a spare dx system, material changes are fast. Roll one unit to the processing machine, while another heats and pre-dries material for the next run.

▶ **Maximum uptime, maximum reliability, smaller footprint**

With significantly reduced part count, easy access and less wear, you can expect many years of trouble-free operation. The weight of the desiccant assembly has been reduced by 70%, the part count reduced by 90%, there are no more indexing bed plates, no more cumbersome 4-way valves and no more messy desiccant beads.

▶ **Precise, adjustable dewpoint control**

The dewpoint control option built into the control system allows you to select a particular dewpoint value, which the control locks onto and maintains. The control then adjusts various dryer functions to precisely hold the dewpoint selected, virtually eliminating any chance of overdrying expensive material.



How it Works

The core of the Carousel Plus Dryer is the Munters® unique fluted desiccant rotor, which is made of molecular sieve desiccant. The molecular sieve has been grown into the rotor's porous fiberglass substrate, preventing desiccant break down and dusting over time.

The desiccant rotor revolves slowly at the rate of 12 revolutions per hour passing through three cycles with each revolution.

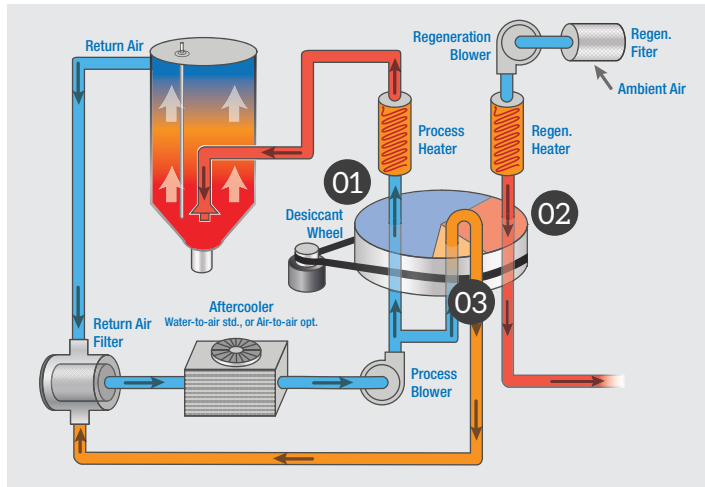

The Benefits

- The high airflow across the rotor surface area produces a resin-drying low dewpoint within five minutes of start-up and offers multi-year media life with virtually no maintenance.
- The continuously revolving rotor provides rock steady temperature and dewpoint control.
- The rotor technology minimizes energy consumption by reducing the structural mass. Less structural mass to heat means less energy wasted.

01

The dry air is dehumidified in the adsorption cycle, capturing and removing moisture from the drying air stream.

02

The desiccant passes into the high temperature regeneration cycle; absorbed moisture is heated and purged out of the desiccant to the atmosphere.

03

The desiccant is then advanced to the post regeneration cooling cycle and cooled with closed loop dry air. This unique closed loop cooling technology eliminating moisture that can cause defects in parts.

Recommended Throughputs (60 Hz chart)*			For 50 Hz Application, Reduce Rates by 17%						
Material	Drying Temp / °F (°C)	Drying Time / Hr †	Initial Moisture	Bulk Density ‡	Model Throughput Rate§ / lb/hr				
					dx15**	dx25**	dx50**	dx75**	dx100**
ABS	180-190 {82-88}	4	0.40	40 {0.64}	15	25	50	75	100
Acetal	180-230 {82-110}	4	0.60	40 {0.64}	13	19	37	55	75
Acrylic	170-180 {77-82}	4	0.30	40 {0.64}	17	29	59	86	116
Nylon	160-180 {71-82}	6	0.40	40 {0.64}	16	27	54	80	108
PBT	210-260 {99-127}	4	0.30	45 {0.72}	17	28	56	83	112
PC	250 {121}	4	0.30	40 {0.64}	16	26	52	77	104
PE (HD/LP) w/40% black	170 {77}	5	-	26-34 {0.42-0.54}	15	25	50	75	100
PET virgin bottle grade	300-350 {144-177}	6	0.30	50 {0.80}	15	25	50	75	100
PETG	140-150 {60-66}	6	0.30	50 {0.80}	16	27	54	80	108
Polysulfone	200-275 {93-135}	4	0.50	50 {0.80}	8	16	32	46	62
Polyurethane	180-210 {82-99}	4	0.50	40 {0.64}	9	17	35	51	70
SAN	160-180 {71-82}	2-4	0.30	45 {0.72}	20	31	63	94	125

Select the right dryer for your application

- 1. Identify the resin and throughput rate.**
Use the chart to quickly select the correct dryer model for your throughput rate.
- 2. Multiply the suggested drying time by your throughput rate to determine the hopper size.** Refer to Conair drying hopper specifications, or contact a Conair representative to determine the correct hopper for your application.
- 3. Select the dryer model and options to suit your application.**
Carousel Plus™ D Series models can be used for individual station drying applications.

Application Notes

- * Material throughputs are based on typical virgin material with initial moisture content as supplied by the material suppliers. Consult Conair if specific initial and final moisture content of your material are known for your application.
- † The parameters of drying temperature and time may vary depending upon the type, grade and manufacturer of the material being processed. Consult your material supplier for their precise recommendations.
- ‡ Unit of measurement for bulk density is lb/ft³ {g/cm³}. Bulk density listed is the nominal weight for typical pellets. The bulk density may vary somewhat depending upon the size and shape of the pellets. The bulk density of regrind may vary widely depending upon the size and the shape of the flake. Be sure to consider the bulk density of the material when selecting and the drying time desired.
- § Throughputs will vary by type of material. Consult Conair concerning throughputs for materials that are not listed here.
- ** All Conair Dryers are equipped with an aftercooler as standard. The aftercooler reduces the temperature of the return air from the drying hopper, improving the efficiency of the desiccant. If using the water-cooled aftercooler option, the aftercooler must be connected to supply water with the proper flow rate and temperature.



DC-C Control Features and Options



Control	DC-C Plus	DC-C Premium
Standard		
Processor / control type	Proprietary	Proprietary
Display / HMI screen	4-inch color	7-inch color
Trending screens (dewpoint, temp., etc.)	●	●
Auto start/stop	1 day/time	7 day/time
English / metric units	●	●
Password protected	●	●
Temperature Setback (manual/auto)	○	●
Dewpoint monitor and control	●	●
Energy Usage Meter	●	●
Audible and Visual alarm	●	●
VNC viewer		●
Air-to-air heat exchange	○	○
Predictive maintenance	●	●
Phase detection	●	●
Available options		
Drying Monitor		○
Vacuum Conveying	○	○
Number of vacuum receivers	1	2
Ratio loading		Conveying dependent
Purge		Conveying dependent
Vacuum fill		Conveying dependent
Modbus TPC Communications		○
H2O flow control		○
UL option		○
Process filter check	○	○
Volatile trap	○	○
Precooler	○	○
Dry air conveying	○	○
Hopper loading (+ ratio)	○	○
Water-cooled aftercooler	○	○

● Standard ○ Option

Hopper capacities

Models	RWH14-2	RWH14-3	RWH14-4	RWH18-6
Performance characteristics				
Volume ft ³ {liter}	2.0 {57}	3.0 {85}	4.0 {113}	6.0 {170}
Capacity @ 35 lb/ft ³ lb {kg}	70 {32}	105 {48}	140 {64}	210 {95}
Capacity @ 52 lb/ft ³ lb {kg}	104 {47}	156 {71}	208 {94}	312 {142}

Models	RWH24-9	RWH24-12	RWH24-18
Performance characteristics			
Volume ft ³ {liter}	9.0 {255}	12.0 {340}	18.0 {509}
Capacity @ 35 lb/ft ³ lb {kg}	315 {143}	420.0 {191}	630.0 {286}
Capacity @ 52 lb/ft ³ lb {kg}	468 {212}	624.0 {283}	936.0 {425}

Refer to the specification table on the next page for standard and optional hopper sizes for each dx dryer.

Drying Monitor – Available with DC-C Premium

Save time and money from the aggravation of improperly dried material.

The Drying Monitor automatically monitors the heat profile inside your drying hopper with a 6-zone temperature probe, to protect resin from over or under-drying. A control alarm and a light tower alert if proper drying is in jeopardy. Advanced notice provides time to correct issues instead of wasted drying and product defects from common issues like: failed or out-of-place process temperature probe, an improperly sized hopper or dryer for the application, lack of resin or loading equipment failure, reduced airflow from dirty filters, kinked hoses and other obstructions, unplanned throughput change and loss of power.

Your DC-C Premium control will alarm on most dryer-related problems, but the Drying Monitor goes further to report proper drying happening inside the drying hopper.

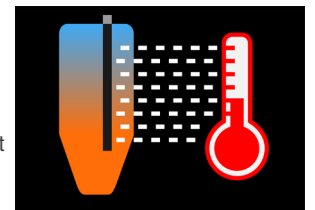

Feature Descriptions

- **Audible and visual alarm** - A combination of a blinking red alarm light and a horn alert the operator to any shut down alarm.
- **Temperature setback** - Automatically reduces the drying temperature to a lower standby mode when the machine throughput is reduced or stopped. * Standard on DC-C Premium controls, optional on DC-C Plus.
- **Dewpoint monitor** - Monitor the performance of the dryer with a digital dewpoint readout of the drying air.
- **Dewpoint control** - Allows the dryer to maintain an operator-selected dewpoint level. This feature helps prevent overdrying of moisture sensitive materials such as Nylon.
- **Communications** - Allows the dryer to be networked to industrial control systems. When a dryer is connected to a network, the controller on the network may read actual temperatures, change setpoints, read dryer status, and process and display this information at a central location. Ethernet communications are available on the DC-C Premium control.
- **Air-to-air heat exchange** - The Optional air-to-air aftercooler means no cooling water hook-up is required for operation. An aftercooler is required to reduce the temperature of the return air from the hopper, which improves the efficiency of the desiccant. The new air-to-air cooler achieves drying efficiency at temperatures up to 375°F {190.5°C}, while saving water and simplifying installation.



Specifications

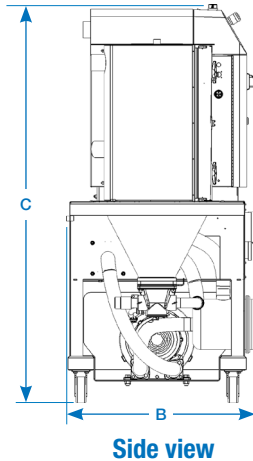
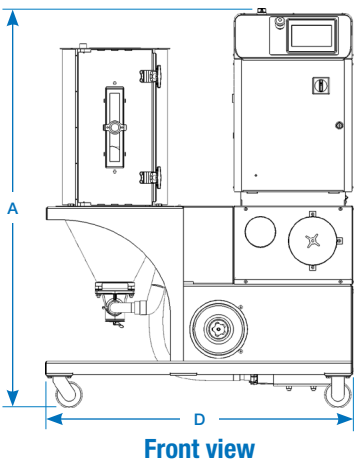

TLR Tube Loader (machine loader) TLR Tube Loader (hopper loader)

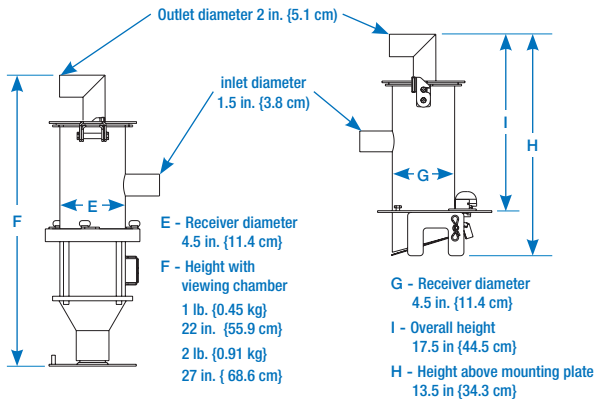

Models	dX15	dX25	dX50	dX75	dX100
Standard hopper models	RWH14-2	RWH14-3	RWH18-6	RWH24-9	RWH24-12
Alternate hopper models	N/A	RWH14-4	N/A	RWH24-12	RWH24-18
Optional hopper loading	TLR				
Optional machine loading	TLR with 1 lb. glass			TLR with 2 lb. glass	

Performance characteristics (with full hopper)	
Drying temperature	150° - 375°F {66 - 191°C}
Dewpoint	-40°F {-40°C}
Standard conveying distance	8 ft {2.44 m} vertical; 6 ft {1.83 m} horizontal
Long distance conveying option	15 ft {4.57 m} vertical; 50 ft {15.24 m} horizontal

Dimensions inches {cm}	
A - Height top of conveying pipe	73.4 {186.5}
B - Overall width	32.5 {82.5}
C - Height to top of hopper (standard)	53.7 {136.4}
C - Height to top of hopper (optional)	N/A
D - Depth	47.1 {119.5}
Drying outlet/inlet tube size OD	2.5 {6.35}

Approximate weight lbs {kg}	
Standard dryer installed	550 {250} 600 {272} 672 {305} 756 {353} 840 {381}
Standard dryer shipping	700 {318} 790 {358} 885 {401} 913 {414} 1064 {483}

Voltage - Full load amps†† (standard/long conveying distance)	
208 V/3 phase/60 Hz	18.2 / 22.2 22.6 / 26.6 29.1 / 33.1 N/A
230 V/3 phase/60 Hz	16.4 / 20.0 20.5 / 24.1 26.3 / 29.9 27.5 / 31.1
400 V/3 phase/50 Hz*	9.6 / 11.6 12.0 / 14.0 15.3 / 17.3 15.7 / 17.7
460 V/3 phase/60 Hz	8.1 / 9.9 10.1 / 11.9 13.0 / 14.8 13.6 / 15.4
575 V/3 phase/60 Hz	6.4 / 8.0 8.0 / 9.6 10.4 / 11.9 10.9 / 12.4

Water-cooled requirements (for aftercooler or precooler)†§	
Recommended temperature**	45° - 85°F {7.2° - 29.4°C}
Water flow gal./min. {liters/min.}	1 {4.6} 2 {9.1}
Water connections	NPT 3/4 inch NPT

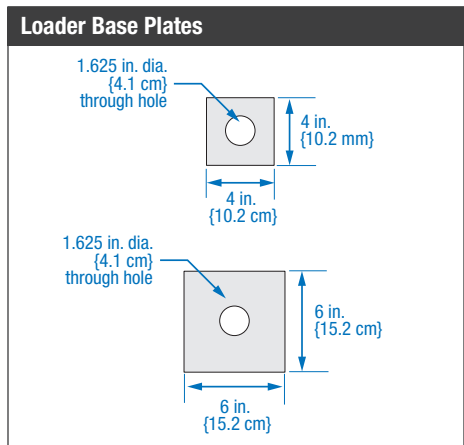

Application Notes

All dryers are supplied with an aftercooler as standard. The aftercooler reduces the temperature of the return air from the drying hopper, improving the efficiency of the desiccant. If using the water-cooled aftercooler option, the aftercooler must be connected to supply water with the proper flow rate and temperature.

When to use additional filtration
The standard return air cartridge filter is sized for the airflow of each dryer model and is suited for most applications. You should consider adding an optional dust collector and/or volatile trap if:

- The material contains excessive fines. An additional dust collector or cyclone will extend time between filter cleaning.
- The material produces volatiles during drying which condense into a waxy or oily residue. A volatile trap will help to protect the desiccant.

Specification Notes

* Dryers running at 50 Hz will have 17% less airflow, and a 17% reduction in material throughput.

† Total kW listed at a process setpoint of 250°F {121°C} and a regeneration temperature of 350°F {177°C}.

‡ When drying below 150°F {66°C} a precooler is required.

§ When ambient temperature is above 110°F {43°C} and drying above 375°F {191°C} a water-cooled aftercooler is required.

**Temperatures above or below the recommended levels may affect dryer performance. Tower, chiller, or municipal water sources can be used.

†† FLA data for reference purposes only. Does not include any options or accessories on equipment. For full FLA detail for power circuit design of specific machines and systems, refer to the electrical diagrams of the equipment order and the nameplate applied to the machine.

Specifications may change without notice. Consult a Conair representative for the most current information.

