

Portable Chillers

**Series 2 Water-Cooled (W2), Air-Cooled (A2)
and
High Ambient Air-Cooled (A2-HA) Models**

Installation

Operation

Maintenance

Troubleshooting

***Instant Access
Parts and Service
(800) 458-1960
(814) 437-6861***

www.conairnet.com



The Conair Group, Inc.
One Conair Drive
Pittsburgh, PA 15202
Phone: (412) 312-6000
Fax: (412) 312-6227

UGH018/1102



WARNING - Reliance on this Manual Could Result in Severe Bodily Injury or Death!

This manual is out-of-date and is provided only for its technical information, data and capacities. Portions of this manual detailing procedures or precautions in the operation, inspection, maintenance and repair of the product forming the subject matter of this manual may be inadequate, inaccurate, and/or incomplete and cannot be used, followed, or relied upon. Contact Conair at info@conairgroup.com or 1-800-654-6661 for more current information, warnings, and materials about more recent product manuals containing warnings, information, precautions, and procedures that may be more adequate than those contained in this out-of-date manual.

Please record your equipment's model and serial number(s) and the date you received it in the spaces provided.

It's a good idea to record the model and serial number(s) of your equipment and the date you received it in the User Guide. Our service department uses this information, along with the manual number, to provide help for the specific equipment you installed.

Please keep this User Guide and all manuals, engineering prints and parts lists together for documentation of your equipment.

Date:
Manual Number: UGH018/1102
Serial number(s):
Model number(s):
Power specifications: Amps
Volts
Phase
Cycle

DISCLAIMER: The Conair Group, Inc., shall not be liable for errors contained in this User Guide or for incidental, consequential damages in connection with the furnishing, performance or use of this information. Conair makes no warranty of any kind with regard to this information, including, but not limited to the implied warranties of merchantability and fitness for a particular purpose.

TABLE OF CONTENTS

INTRODUCTION	1-1
Purpose of the User Guide	1-2
How the Guide is Organized	1-2
Your Responsibility as a User	1-2
ATTENTION: Read this so no one gets hurt	1-3
DESCRIPTION	2-1
What is the Portable Chiller?	2-2
Typical Applications	2-3
Limitations	2-3
How it Works: Water-cooled Portable Chiller	2-4
How it Works: Air-cooled Portable Chiller	2-6
Portable Chiller Features	2-8
Specifications	2-10
Pump Curves	2-13
INSTALLATION	3-1
Unpacking the Boxes	3-2
Warnings and Cautions	3-3
Preparing for Installation	3-4
Making Process Plumbing Connections	3-5
Filling the Chiller	3-6
Checking Refrigerant Charge	3-8
Connecting the Main Power Source	3-9
Checking Electrical Connections	3-10
Initially Warming the Chiller	3-10
Checking Pump Rotation	3-11
Checking for Leaks	3-12
Initially Running the Chiller	3-13
Connecting the Remote Control	3-14
Stopping the Chiller	3-14
OPERATION	4-1
PLC Control Features	4-2
Before Starting	4-3
Powering Up	4-4
Running/Stopping the Chiller	4-5
Viewing Status Screens	4-6
Programming Settings	4-8
Changing Setpoint Temperature	4-9
Resetting PID Settings	4-10
Changing High Temperature Deviation	4-11
Setting Percent Glycol	4-12
Setting Fan Setpoints	4-14
Selecting the Temperature Scale	4-5
Setting Auto Tune Mode	4-16
Setting Discharge Pressure Setpoint	4-18
Setting PID Values	4-19
Manually Starting/Stopping the Pump	4-20

TABLE OF CONTENTS

MAINTENANCE5-1

Maintenance Features	5-2
Warnings and Cautions	5-3
Preventative Maintenance Schedule	5-4
Entering Maintenance Screens	5-6
Viewing Cycle Screens	5-7
Placing Compressors into Service	5-8
Checking Electrical Connections	5-9
Cleaning the Evaporator or Water-cooled Condenser	5-10
Cleaning the Air-cooled Condenser	5-11
Checking the Refrigerant Charge	5-12
Checking Reservoir Level	5-13

TROUBLESHOOTING6-1

Before Beginning	6-2
A Few Words of Caution	6-3
Identify the Cause of a Problem	6-3
Answering Alarms	6-4
Alarm Conditions	6-5
Alarm Errors	6-8
Alarm History Screens	6-9
Alarm Table	6-5
Control Problems	6-6
Alarm Conditions	6-8
Checking and Replacing Switches	6-27
Checking the Pressure Transducer	6-28
Replacing the RTD	6-29
Checking the Temperature Transmitter and RTD	6-30
Replacing the Temperature Transmitter	6-32
Removing Pump Components	6-33
Replacing Overload Modules	6-34
Replacing the Contactor	6-35
Replacing the PLC	6-36

APPENDIXA-1

Customer Service	A-1
Maintenance Log	B-1
Pressure Tables	C-1
Overhead Plumbing Details	D-1

PARTS AND DIAGRAMSP/D-1

INTRODUCTION

- *Purpose of the User Guide1-2*
- *How the Guide is Organized . . .1-2*
- *Your responsibility as a user . .1-2*
- *ATTENTION: Read this so
no one gets hurt1-3*

PURPOSE OF THE USER GUIDE

This User Guide describes Conair's Series 2 Water-cooled and Air-cooled Portable Chillers and explains step-by-step how to install, operate, maintain and repair this equipment.

Before installing this product, please take a few moments to read the User Guide and review the diagrams and safety information in the instruction packet. You also should review manuals covering associated equipment in your system. This review won't take long, and it could save you valuable installation and operating time later.

HOW THE GUIDE IS ORGANIZED

Symbols have been used to help organize the User Guide and call your attention to important information regarding safe installation and operation.



Symbols within triangles warn of conditions that could be hazardous to users or could damage equipment. Read and take precautions before proceeding.



Numbers within shaded squares indicate tasks or steps to be performed by the user.



A diamond indicates the equipment's response to an action performed by the user.



An open box marks items in a checklist.



A shaded circle marks items in a list.

YOUR RESPONSIBILITY AS A USER

You must be familiar with all safety procedures concerning installation, operation and maintenance of this equipment. Responsible safety procedures include:

- Thorough review of this User Guide, paying particular attention to hazard warnings, appendices and related diagrams.
- Thorough review of the equipment itself, with careful attention to voltage sources, intended use and warning labels.
- Thorough review of instruction manuals for associated equipment.
- Step-by-step adherence to instructions outlined in this User Guide.

We design equipment with the user's safety in mind. You can avoid the potential hazards identified on this machine by following the procedures outlined below and elsewhere in the User Guide.

 **ATTENTION:**
**READ THIS SO NO
ONE GETS HURT**



WARNING: Improper installation, operation, or servicing may result in equipment damage or personal injury.

This equipment should only be installed, adjusted, and serviced by qualified technical personnel who are familiar with the construction, operation, and potential hazards of this type of machine.

All wiring, disconnects and fuses should be installed by qualified electrical technicians in accordance with electrical codes in your region. Always maintain a safe ground. Do not operate the equipment at power levels other than what is specified on the machine serial tag and data plate.



WARNING: Electrical hazard

Before performing any work on this item, disconnect and lock out electrical power sources to prevent injury from unexpected energization or startup.



CAUTION: Hot Surfaces

Always protect yourself from hot surfaces when working on the Portable Chiller, especially when working on or around the compressor and condenser. These devices can reach up to 160°F (71°C). Allow these devices to cool before performing any maintenance or troubleshooting.



CAUTION: Ventilation hazard

The unit requires a clean and well ventilated operating environment. Do not place anything on top of the unit while operating. Units with fans require unrestricted outlet air flow.

Water-cooled units require a minimum of one foot clearance around the perimeter for serviceability. Air-cooled units require a minimum of two feet clearance around the perimeter for serviceability and proper air flow.



WARNING: Hazardous substance

When burned, Freon R22 refrigerant forms Phosgene gas. If the chiller is placed in the vicinity of equipment with combustible systems, the combustion air intake must be ducted in from the outside and sealed in such a manner as to prevent any refrigerant from entering the combustion chamber. Refer to the Material Safety Data Sheet for Freon R22 included in the appendix. This sheet explains the potential hazards and how to avoid them.

DESCRIPTION

- *What is the Portable Chiller? . . .*2-2
- *Typical Applications*2-3
- *Limitations*2-3
- *How it Works: Water-cooled*
 - Portable Chiller*2-4
- *How it Works: Air-cooled*
 - Portable Chiller*2-6
- *Portable Chiller Features*2-8
- *Specifications*2-10
- *Pump Curves*2-13

WHAT IS THE PORTABLE CHILLER?

The Conair Series 2 Portable Chillers provide self-contained sources of chilled water and are available in either water- or air-cooled models with ranges from 3.5 Hp to 30 Hp (approximate capacities of 3.5 tons to 30 tons of refrigeration). Pump selections are available to match most process flow and pressure requirements.

The normal temperature range of discharge chilled water is 20°F to 70°F. For applications requiring 40 °F and lower mix glycol with the water to the correct percentage.

The Air-cooled Portable Chiller A2 Models and Water-cooled Portable Chiller W2 Models are designed to provide chilled fluid for industrial applications requiring 24-hour-a-day performance. Units are totally self-contained for easy, economical installation. All parts wetted by the process are non-ferrous.

To operate, simply connect the power source, process piping and fill with water or with industrial grade ethylene glycol or propylene glycol (but not automotive antifreeze).

These chillers are ideal for machine-side cooling to maintain process temperatures in an injection molding machine or extruder and wherever you need a small, moveable cooling unit. Nominal capacities range from 3.5 to 30 tons for the both the water-cooled and air-cooled models. Capacities are based on standard pump sizes and delivering 50°F (10°C) water.

Operation of these units differ only in the medium used to remove heat from the refrigerant in the condensers. Water-cooled models use 85°F (29°C) or lower cooling water from a tower, well, or city service; air-cooled models use 95°F (35°C) maximum ambient air; and high ambient models use 120°F (49°C) maximum ambient air.

Choose Water-cooled Portable Chillers where tower water or another inexpensive water source is available. Choose Air-cooled models for maximum portability of the unit or if water is unavailable.

Brazed plate condensers are standard equipment on all water-cooled models. Air-cooled models use copper-fin tube condensers.

All standard voltages are available.

The Conair A2 and W2 Portable Chillers can be used anywhere a reliable source of process cooling water - with stable temperature control - is required.

TYPICAL APPLICATIONS

These portable chillers are available for cooling injection molding, blow molding, thermoforming, extrusion, air compressors, metal plating, anodizing, degreasing, heatset/web offset printing presses, and dryer after-coolers.

Roll the air-cooled model next to the heat source, connect it, and plug it in. They can operate almost anywhere.

The water-cooled models require a source of condenser water. Normally used in conjunction with a recirculating evaporative cooling tower system, the units have slightly better operating energy efficiencies.

Conair Series 2 Portable Chillers are designed to provide chilled water for industrial applications requiring 24-hour-a-day performance. Units are self-contained and easy to install and maintain. Choose the Conair Series 2 Portable Chillers based on the cooling load and the capacity of the unit. Pick your Conair Series 2 Portable Chillers based on:

LIMITATIONS

- **Cooling load**

Choose a portable chiller that has 10% more capacity than the process load.

- **Location**

Choose a water-cooled model if the unit will be located in an air-conditioned area. Choose the water-cooled model if a source of condenser water is readily available (i.e. cooling tower water). Do not locate the portable chiller outside unless the unit is specially modified.

- **Temperature**

The portable chiller needs to provide a cooling temperature less than 70°F (21°C).

Use this information as a general guide. Consult your Conair representative for assistance when choosing a Conair Portable Chiller.

HOW IT WORKS: WATER-COOLED PORTABLE CHILLER

Process circulation

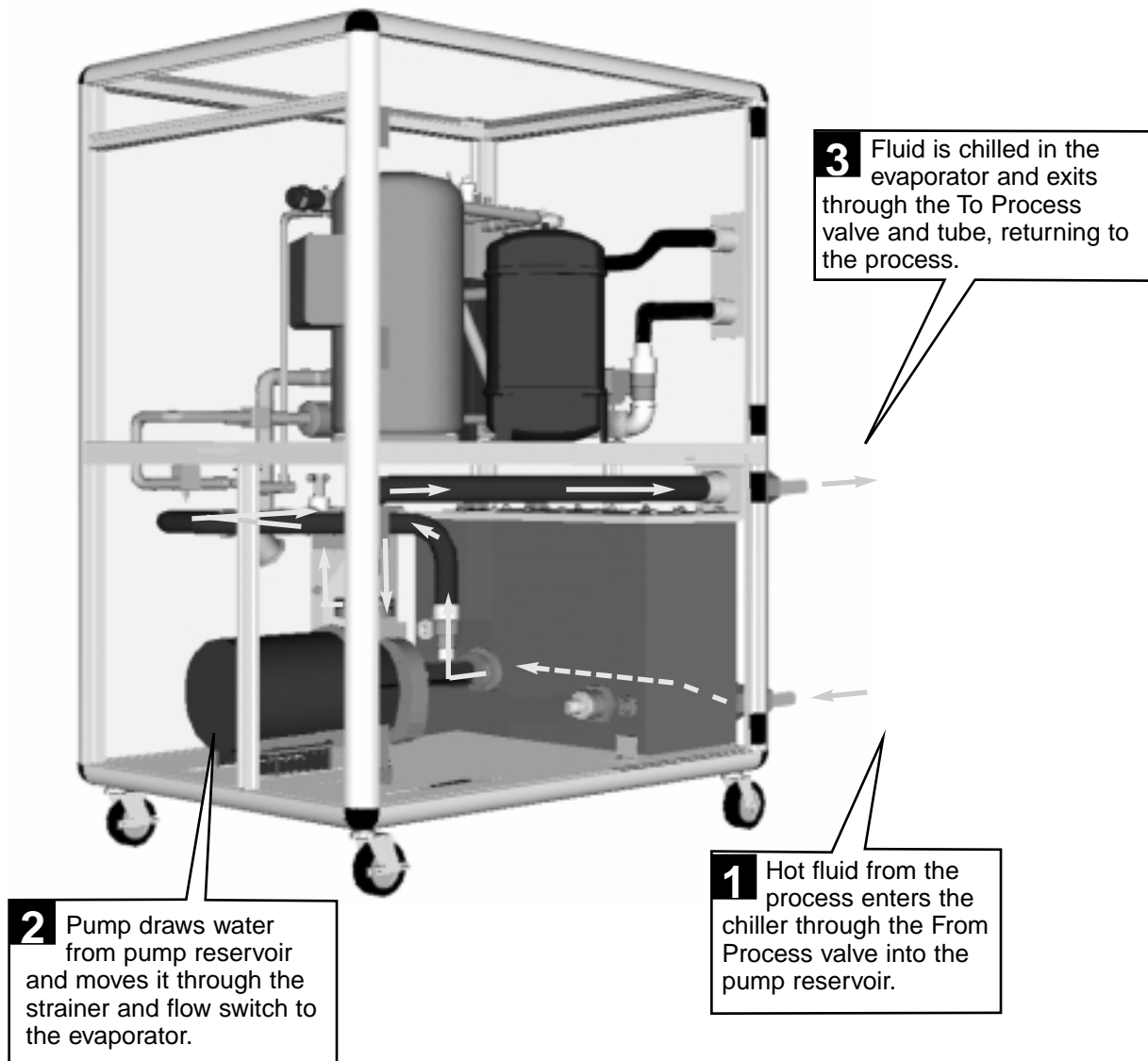

Refrigerant circulation

HOW IT WORKS: WATER-COOLED CONT'D

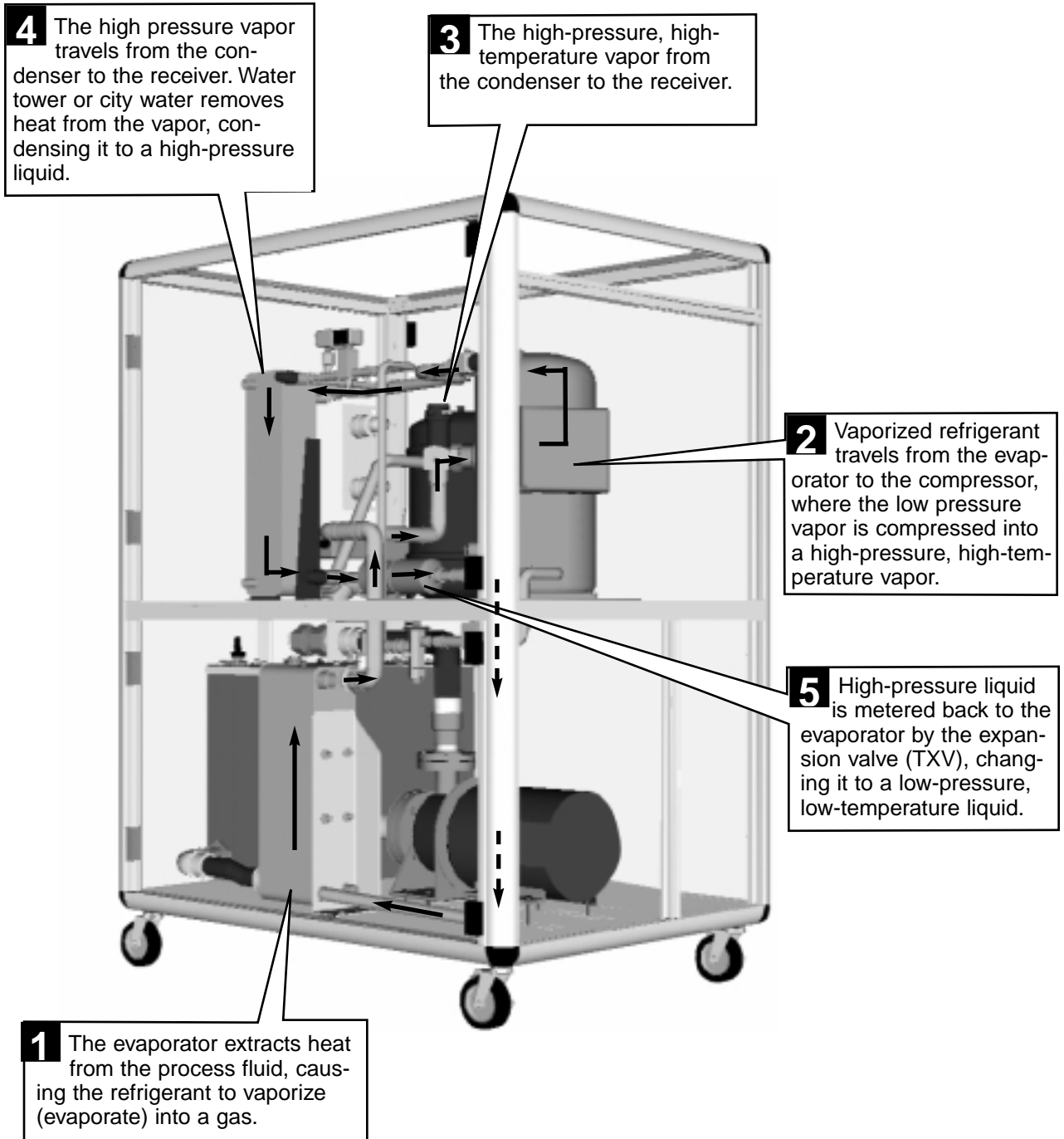

HOW IT WORKS: AIR-COOLED PORTABLE CHILLER

Process circulation

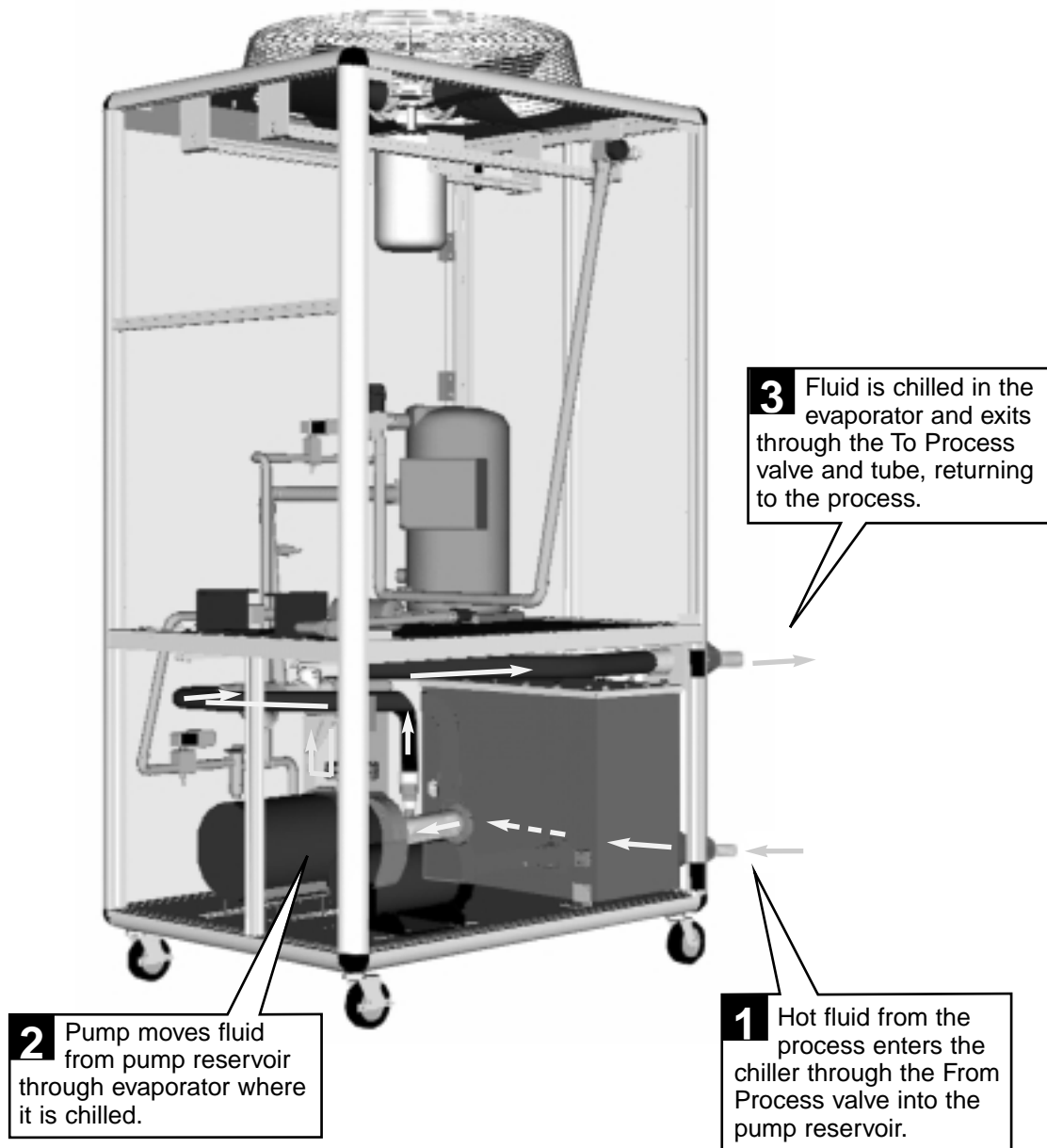

Refrigerant circulation

HOW IT WORKS: AIR-COOLED CONT'D

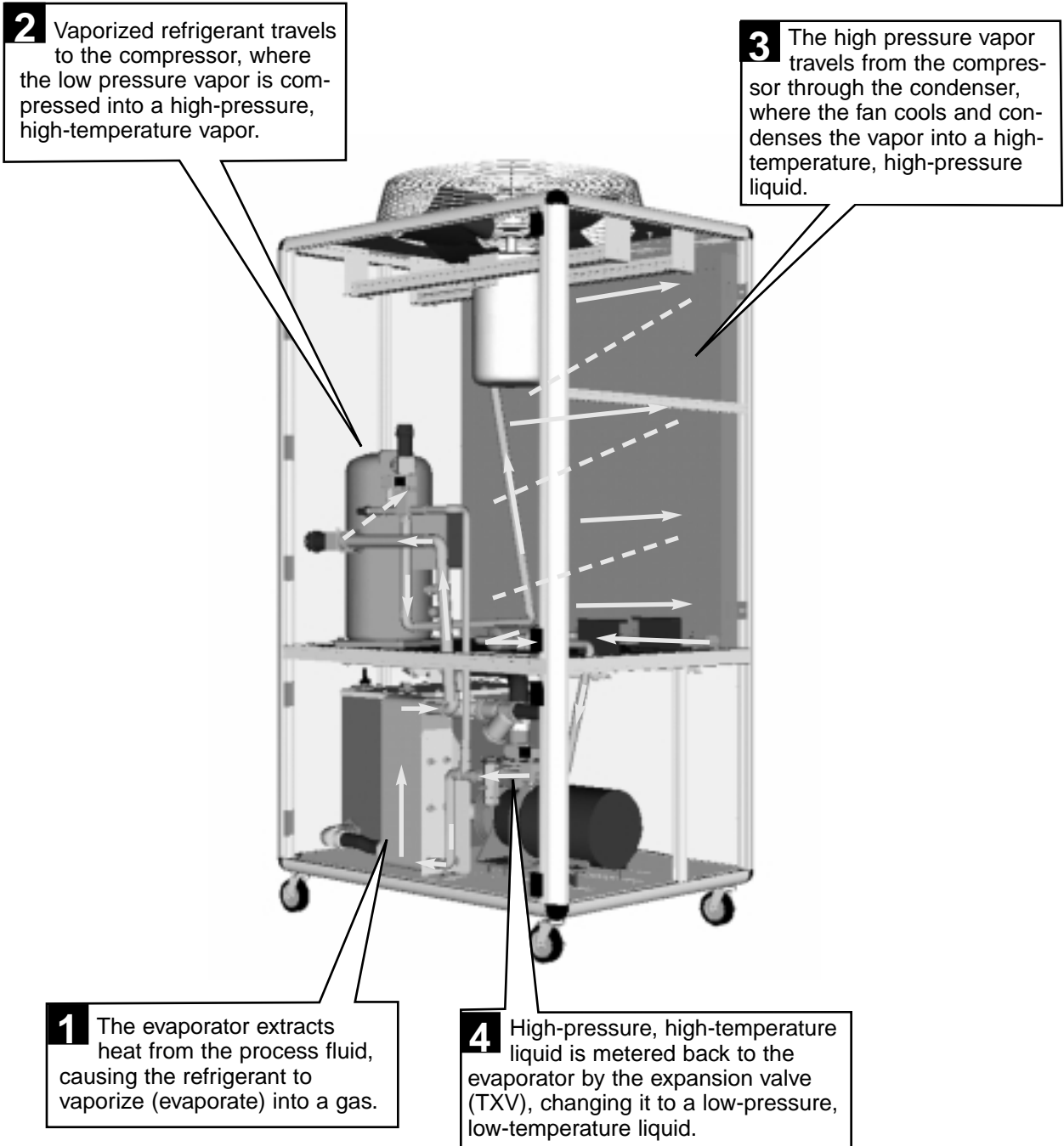

PORTABLE CHILLER FEATURES

Water-cooled Models

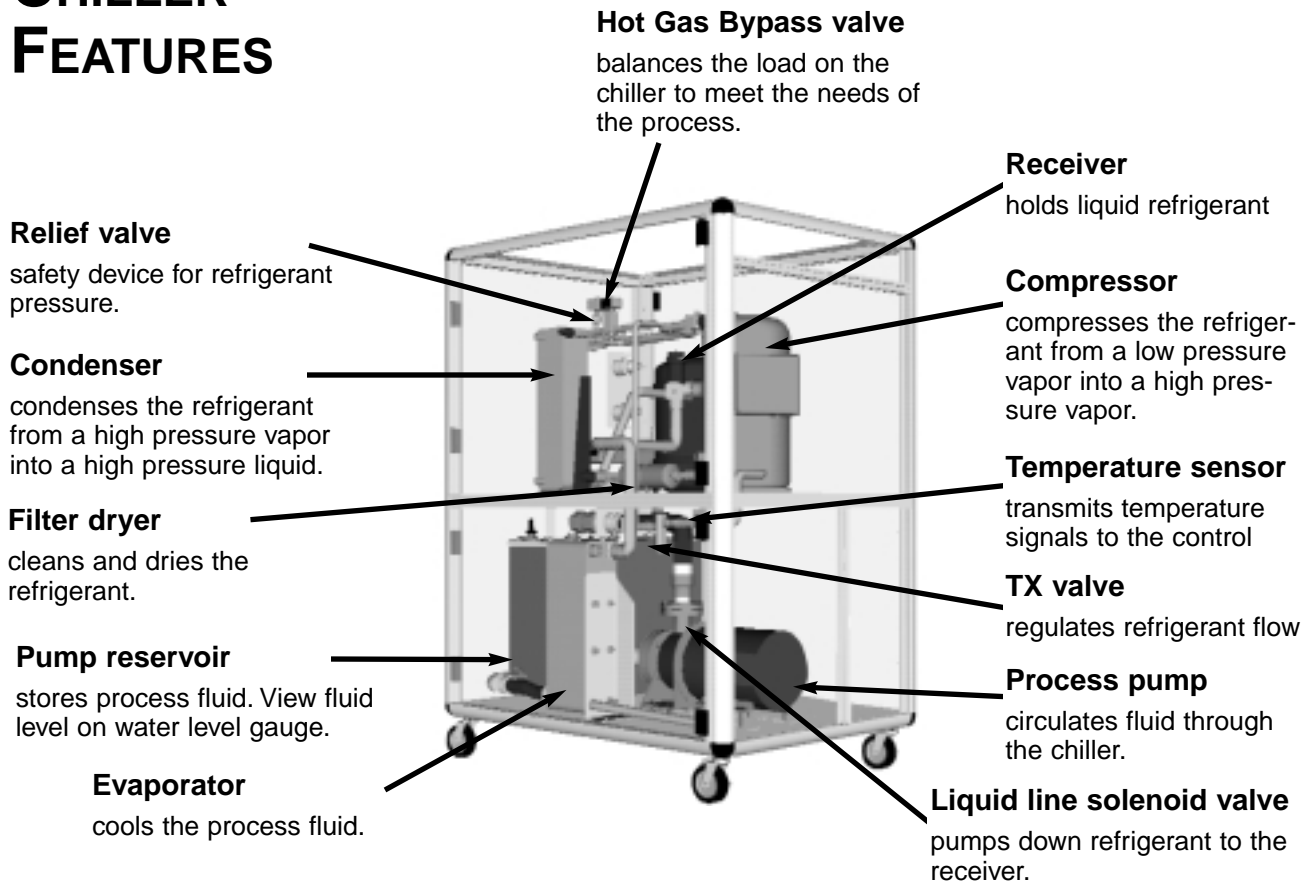

Options include:

- 60 Hz process pump
 - 2 Hp for W2-3.5
 - 3 Hp for W2-3.5, W2-5, W2-7.5, W2-10
 - 5 Hp for W2-5, W2-7.5, W2-10, W2-15
 - 7.5 Hp for W2-7.5, W2-10, W2-15, W2-20
 - 10 Hp for W2-10, W2-15, W2-20, W2-25, W2-30
 - 15 Hp for W2-15, W2-20, W2-25, W2-30
- 50 Hz process pump
 - 2 Hp for W2-3.5
 - 3 Hp for W2-3.5, W2-5, W2-7.5, W2-10
 - 5 Hp for W2-5, W2-7.5, W2-10, W2-15
 - 7.5 Hp for W2-7.5, W2-10, W2-15, W2-20
 - 10 Hp for W2-10, W2-15, W2-20, W2-25, W2-30
- Process bypass line and valve
- No reservoir/pump
- Auto fill reservoir
- Visual/audible alarm
- Remote/redundant hand control with 30 ft. or 50 ft. cable
- UL labeled controls

Air-cooled Models

PORTABLE CHILLER FEATURES

Condenser

changes the refrigerant from a high pressure vapor into a high pressure liquid.

Fan

circulates air across the condenser to condense refrigerant

Hot Gas Bypass valve

balances the load on the chiller to meet the needs of the process.

Compressor

compresses the refrigerant from a low pressure vapor into a high pressure vapor.

Pump reservoir

stores process fluid. View fluid level on water level gauge

Evaporator

cools the process fluid

Filter dryer

cleans and dries the refrigerant.

Temperature sensor

transmits temperature signals to the control

TX valve

regulates refrigerant flow

Process pump

circulates fluid through the chiller.

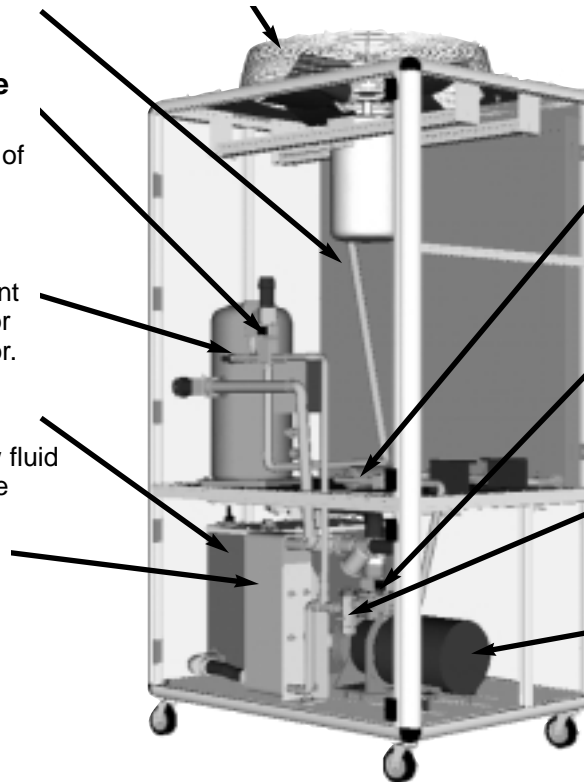

Options include:

- 60 Hz process pump
 - 2 Hp for A2-3.5
 - 3 Hp for A2-3.5, A2-5, A2-7.5, A2-10
 - 5 Hp for A2-5, A2-7.5, A2-10, A2-15
 - 7.5 Hp for A2-7.5, A2-10, A2-15, A2-20
 - 10 Hp for A2-10, A2-15, A2-20, A2-25, A2-30
 - 15 Hp for A2-15, A2-20, A2-25, A2-30
- 50 Hz process pump
 - 2 Hp for A2-3.5
 - 3 Hp for A2-3.5, A2-5, A2-7.5, A2-10
 - 5 Hp for A2-5, A2-7.5, A2-10, A2-15
 - 7.5 Hp for A2-7.5, A2-10, A2-15, A2-20
 - 10 Hp for A2-10, A2-15, A2-20, A2-25, A2-30
- Process bypass line and valve
- No reservoir/pump
- Auto fill reservoir
- Visual/audible alarm
- Remote/redundant hand control with 30 ft. or 50 ft. cable
- UL labeled controls

SPECIFICATIONS

Air-cooled Models

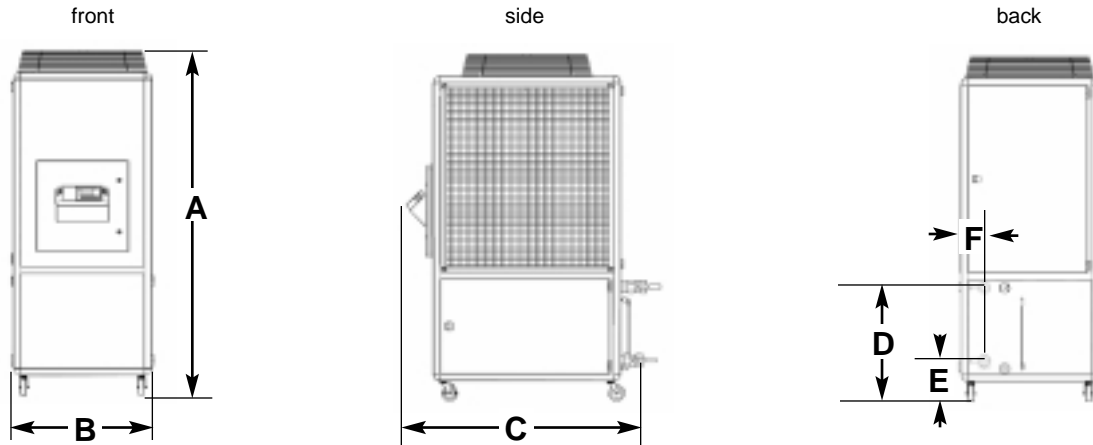

MODEL	A2-3.5	A2-5	A2-7.5	A2-10	A2-15	A2-20	A2-25	A2-30								
Performance characteristics																
Capacity [†] tons	3.2	4.7	6.9	9.9	14.6	19.9	24.6	28.9								
Compressor Hp {kW}	3.5 {2.6}	5 {3.7}	7.5 {5.6}	10 {7.5}	15 {11.2}	20 {14.9}	25 {18.6}	30 {22.4}								
Pump Hp {kW}																
60 Hz	1 {0.7}	1.5 {1.1}	1.5 {1.1}	1.5 {1.1}	2 {1.5}	3 {2.2}	3 {2.2}	5 {3.7}								
50 Hz	1.5 {1.1}	1.5 {1.1}	1.5 {1.1}	2 {1.5}	2 {1.5}	3 {2.2}	3 {2.2}	5 {3.7}								
Chilled water flow [‡] gpm {lpm}	7.7 {29}	11.2 {42}	16.6 {63}	23.9 {90}	34.9 {132}	47.7 {180}	59.1 {224}	69.4 {263}								
Chilled water pressure [§] psi {bar}	36.6 {139}	37.7 {143}	31.8 {120}	37.0 {40}	42.8 {162}	36.5 {138}	33.6 {127}	49.8 {189}								
Reservoir capacity gal {l}	15 {57}	15 {57}	25 {95}	25 {95}	25 {95}	46 {174}	46 {174}	46 {174}								
Condenser fans	1	1	1	1	1	1	1	1								
Condenser fan power Hp {kW}	1	1.5	1	1.5	5	7.5	7.5	10								
Condenser air flow	2546	3697	5402	7640	11,160	15,679	18,800	22,321								
ft ³ /min {liters/min}	{72,095}	{104,688}	{152,968}	{216,341}	{316,016}	{443,980}	{532,357}	{632,060}								
Dimensions in {mm}																
A-Height	64 {1626}			90 {2286}			94 {2388}									
B-Width	36 {914}			36 {914}			48 {1219}									
C-Length	48 {1219}			48 {1219}			48 {1219}									
D-Height to From Process valve	21 {533}			29.5 {749}			35 {889}									
E-Height to To Process valve	10.5 {267}			10.5 {267}			11 {279}									
F-Distance to valves	6 {152}			6 {152}			6 {152}									
Weight lb {kg}																
Installed	1270 {576}	1370 {621}	1570 {712}	1680 {762}	1730 {785}	1780 {807}	1880 {853}	1980 {898}								
Shipped	1100 {499}	1200 {544}	1400 {635}	1500 {680}	1550 {703}	1600 {726}	1700 {771}	1800 {816}								
Utility requirements																
Process connections NPT in	1		1.5		1.5		1.5		1.5		2		2		2	
Power consumption amps	run	full	run	full	run	full	run	full	run	full	run	full	run	full	run	full
230V/3 phase/60hz*	17.1	23.1	21.5	32.5	30.7	38.4	36.9	51.8	55.9	73.2	82.6	112.0	91.0	122.4	112.2	145.5
220V/3 phase/50hz*	21.5	28.3	26.7	34.8	36.5	42.1	48.3	58.9	65.4	76.3	96.3	116.6	105.9	127.4	131.2	151.6
460V/3 phase/60hz	8.5	11.6	10.7	16.3	15.3	19.2	18.4	25.9	27.9	36.3	41.2	56.0	45.4	61.2	56.0	72.8
380-420V/3 phase/50hz*	10.7	13.9	13.3	17.0	18.2	20.5	24.1	28.7	32.7	37.2	48.0	56.8	52.8	62.0	65.5	73.9
575V/3 phase/60hz*	6.8	9.2	8.6	13.0	12.2	15.4	14.7	20.7	22.3	29.3	32.9	44.8	36.3	49.0	44.8	58.2
380V/3 phase/60hz*	10.3	14.0	13.0	19.7	18.5	23.2	22.3	31.4	33.8	44.3	49.9	67.8	55.0	74.1	67.8	88.1

SPECIFICATION NOTES

[†] Based on 50°F (10°C) water temperature (100% water) leaving the chiller, standard pump selections, 95°F (35°C) ambient air conditions for the 60 Hz units. For the 50 Hz units, multiply the capacity by 0.8. Consult factory for other conditions. Capacity ratings are (+) 5% based on compressor manufacturer's ratings and are subject to change without notice.

[‡] Based on 50°F (10°C) water temperature leaving the chiller and 60°F (16°C) water temperature returning to the chiller.

[§] Pressure at pump discharge. See Pressure Tables in the Appendix for Evaporator and Condenser pressure drops.

* Optional

Water-cooled Models

SPECIFICATIONS

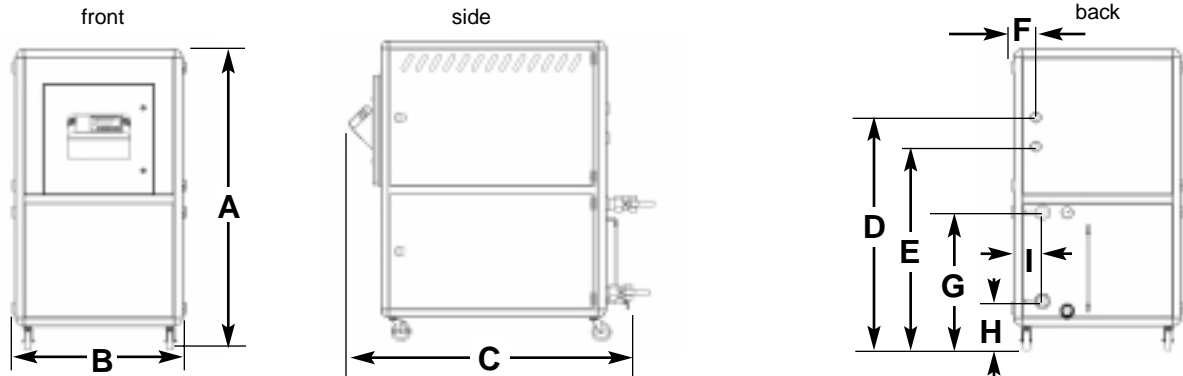

MODEL	W2-3.5	W2-5	W2-7.5	W2-10	W2-15	W2-20	W2-25	W2-30								
Performance characteristics																
Capacity [†] tons	3.3	4.8	7.1	10.2	14.9	20.4	25.3	29.7								
Compressor Hp {kW}	3.5 {2.6}	5 {3.7}	7.5 {5.6}	10 {7.5}	15 {11}	20 {15}	25 {19}	30 {22}								
Pump Hp {kW}																
60 Hz	1 {0.8}	1.5 {1.1}	1.5 {1.1}	1.5 {1.1}	2 {1.5}	3 {2.2}	3 {2.2}	5 {3.7}								
50 Hz	1.5 {1.1}	1.5 {1.1}	1.5 {1.1}	2 {1.5}	2 {1.5}	3 {2.2}	3 {2.2}	5 {3.7}								
Chilled water flow [‡] gpm {lpm}	7.9 {29.9}	11.5 {43.5}	17.0 {64.4}	24.5 {92.7}	35.8 {136}	49.1 {186}	60.6 {229}	71.2 {270}								
Chilled water pressure [§] psi {bar}	36.1 {2.5}	37.4 {2.6}	31.3 {2.2}	31.9 {2.2}	41.6 {2.9}	35.6 {2.5}	32.8 {2.3}	48.8 {3.4}								
Reservoir capacity gal {l}	15 {57}	15 {57}	25 {95}	25 {95}	25 {95}	46 {174}	46 {174}	46 {174}								
Condenser water flow gpm {lpm}	10.2 {38.6}	14.8 {56.0}	21.6 {81.0}	30.6 {116}	44.7 {169}	61.2 {232}	75.3 {285}	89.3 {338}								
Dimensions in {mm}																
A-Height	57 {1448}		65 {1651}			71 {1803}										
B-Width	36 {914}		36 {914}			48 {1219}										
C-Length	48 {1219}		48 {1219}			48 {1219}										
D-Height to condenser out	41.8 {1062}		50 {1270}			53.8 {1367}										
E-Height to condenser in	35.5 {902}		43.75 {1111}			46 {1168}										
F-Distance to valve	4.5 {114}		4.75 {121}			3.75 {95}										
G-Height to To Process valve	21 {533}		29.5 {749}			35 {889}										
H-Height to From Process valve	10.5 {267}		10.5 {267}			11 {279}										
I-Distance to valves	6 {152}		6 {152}			6 {152}										
Weight lb {kg}																
Installed	1047 {475}	1180 {535}	1420 {644}	1430 {649}	1480 {671}	1580 {717}	1680 {762}	1780 {807}								
Shipped	877 {398}	1010 {458}	1250 {567}	1260 {576}	1300 {590}	1400 {635}	1500 {680}	1600 {726}								
Utility requirements																
Process connections NPT in	1		1.5		1.5		1.5		1.5		2		2		2	
Condenser water NPT in	1		1.5		1.5		1.5		2		2		2		2	
Power consumption amps	run	full	run	full	run	full	run	full	run	full	run	full	run	full	run	full
230V/3 phase/60hz*	12.7	18.5	16.4	25.9	25.4	33.8	31.4	45.2	41.2	54.5	61.4	87.8	70.0	98.2	84.8	114.7
220V/3 phase/50hz	15.5	21.4	19.1	27.0	29.4	35.2	37.8	47.9	47.7	58.8	71.1	91.3	81.0	102.1	98.3	119.4
460V/3 phase/60hz*	6.3	9.3	8.1	13.0	12.6	16.9	15.6	22.6	20.5	28.3	30.6	43.9	34.9	49.1	42.3	57.4
380-420V/3 phase/50hz*	7.7	10.4	9.5	13.1	14.7	17.1	18.9	23.2	23.8	28.4	36.4	44.1	40.4	49.3	49.0	57.8
575V/3 phase/60hz*	5.1	7.4	6.5	10.4	10.1	13.5	12.5	18.1	16.4	22.6	24.5	35.1	27.9	39.3	33.8	45.9
380V/3 phase/60hz*	7.7	11.2	9.9	15.7	15.3	20.5	18.9	27.4	24.9	34.2	37.0	53.1	42.3	59.4	51.2	69.4

5SPECIFICATION NOTES

[†] Based on 50°F (10°C) water temperature (100% water) leaving the chiller, standard pump selections, 85°F (27°C) condenser water supply @ 25 psi minimum, for the 60 Hz units. For the 50 Hz units, multiply the capacity by 0.8 Consult factory for other conditions. Capacity ratings are (+) 5% based on compressor manufacturer's ratings and are subject to change without notice.

[‡] Based on 50°F (10°C) water temperature leaving the chiller and 60°F (16°C) water temperature returning to the chiller.

[§] Pressure at pump discharge. See Pressure Tables in the Appendix for Evaporator and Condenser pressure drops.

* Optional

SPECIFICATIONS

High ambient models

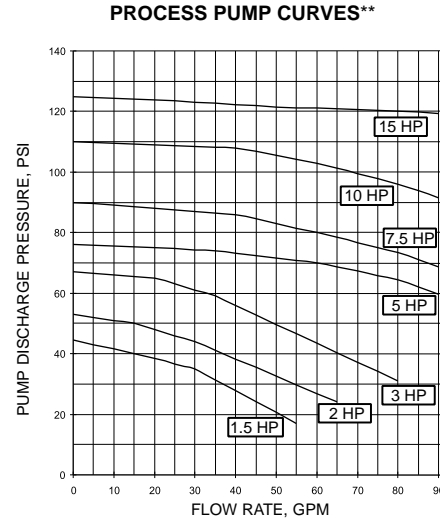
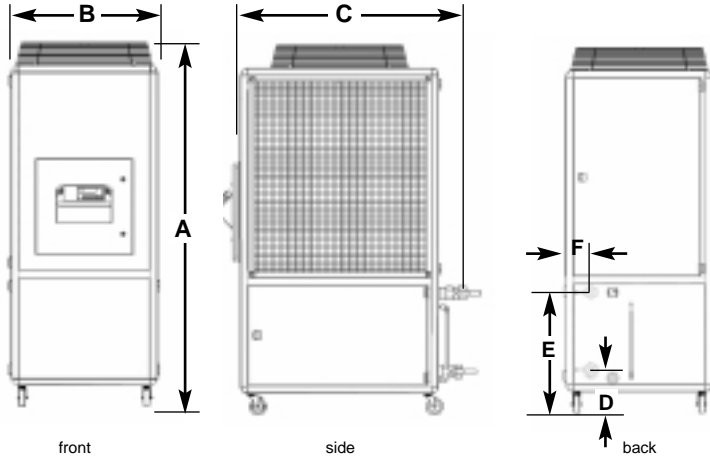

MODEL	A2-5HA		A3-5HA		A2-7.5HA		A3-7.5HA		A2-10HA	
Performance characteristics										
Capacity* tons @ 50°F LWT	3.9		3.8		6.0		5.6		8.5	
120°F {49°C} ambient	3.9		3.8		6.0		5.6		8.5	
Compressor Hp {kW}	5 {2.6}		5 {2.6}		7.5 {5.6}		7.5 {5.6}		10 {7.5}	
Process pump Hp {kW}	1.5 {1.1}		1.5 {1.1}		1.5 {1.1}		1.5 {1.1}		1.5 {1.1}	
Recirculation pump Hp {kW}	---		0.5 {0.4}		---		0.5 {0.4}		---	
Process flow† gpm {lpm}	9.36 {37}		18.2 {69}		14.4 {55}		26.9 {112}		20.4 {78}	
Process pressure‡ psi {bar}	44 {3}		40 {2.8}		42 {2.9}		38 {2.6}		41 {2.8}	
Reservoir capacity gal {liters}	15 {57}		15 {57}		15 {57}		15 {57}		25 {95}	
Condenser fan power Hp {kW}	1.5		1.5		1.5		1.5		3	
Condenser air ft³/min {cu M/min}	3725 {105}		3550 {100}		5650 {160}		5425 {153}		7800 {220}	
Process Connections NPT	1-1/2		1-1/2		1-1/2		1-1/2		1-1/2	
Dimensions in {mm}										
A - Height			64 {1626}						90 {2286}	
B - Width			36 {914}						36 {914}	
C - Length			48 {1219}						48 {1219}	
D - Height to From Process valve			21 {533}						29.5 {749}	
E - Height to To Process valve			10.5 {267}						10.5 {267}	
F - Distance to valves			6 {152}						6 {152}	
Weight lb {kg}										
Installed	1370 {621}		1470 {667}		1570 {712}		1680 {762}		1680 {762}	
Shipping	1200 {544}		1300 {589}		1400 {635}		1500 {680}		1500 {680}	
Voltages running/full load amps										
230V/3 phase/60hz	run	full	run	full	run	full	run	full	run	full
460V/3 phase/60hz	21.5	32.5	23.2	34.5	30.7	38.4	32.4	40.4	36.9	51.8
	10.7	16.3	11.6	17.2	15.3	19.2	16.1	20.1	18.4	25.9

SPECIFICATION NOTES

* Based on 50°F (10°C) water temperature (100% water) leaving the chiller, standard pump selections, Consult factory for other conditions. Capacity ratings are ± 5% based on compressor manufacturer's ratings and are subject to change without notice. 15 Hp models are only rated up to 115°F (45°C).

† Series 2 based on 50°F (10°C) water temperature leaving the chiller and 60°F (16°C) water temperature returning to the chiller. Series 3 based on 50°F (10°C) water temperature leaving the chiller and 55°F (13°C) water temperature returning to the chiller.

‡ Standard pump pressure at pump discharge (unit discharge pressure on series 3).

**Pump curves are non-overloading using the service factor of the ODP motors.

PUMP CURVES

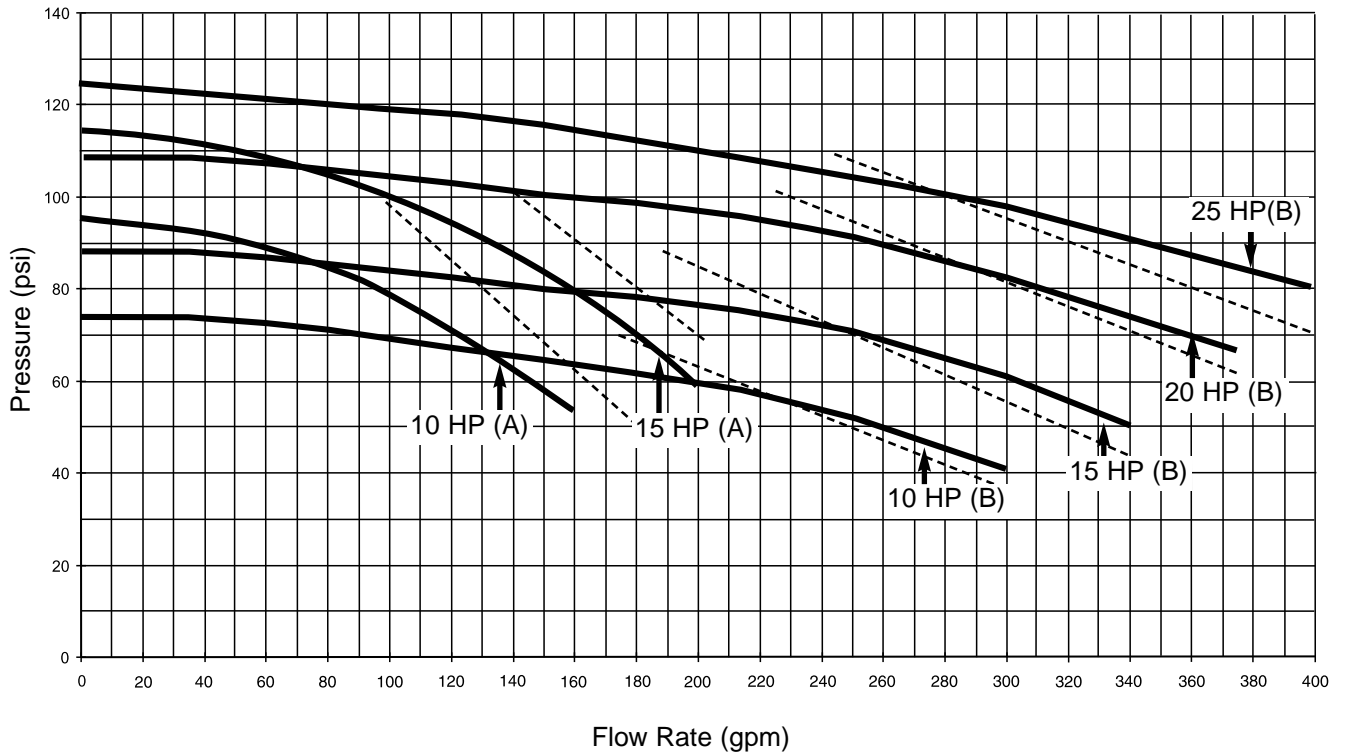
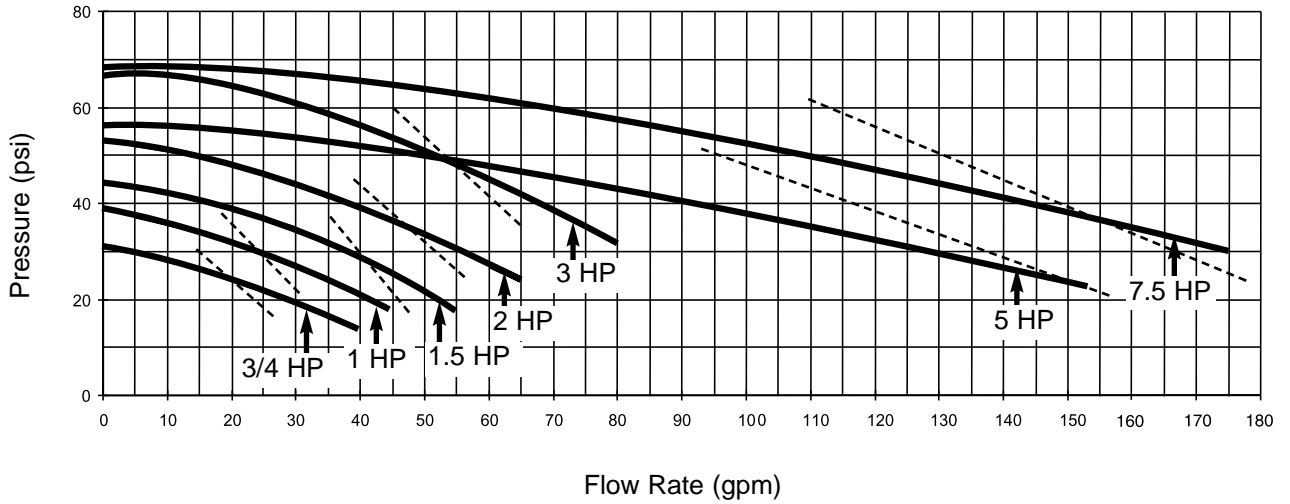

These pump curves are non-overloading using the service factor of the motors.

Dotted line ----- shows the optional TEFC pump overload.

INSTALLATION

- **Unpacking the Boxes**3-2
- **Warnings and Cautions**3-3
- **Preparing for Installation**3-4
- **Making Process Plumbing**
 - Connections**3-5
- **Filling the Chiller**3-6
- **Checking Refrigerant Charge**3-8
- **Connecting the Main**
 - Power Source**3-9
- **Checking Electrical Connections** 3-10
- **Initially Warming the Chiller**3-10
- **Checking Pump Rotation**3-11
- **Checking for Leaks**3-12
- **Initially Running the Chiller**3-13
- **Connecting the Remote Control** .3-14
- **Stopping the Chiller**3-14

UNPACKING THE BOXES

The portable chiller comes fully assembled in a single crate. The Air cooled units are shipped without the casters attached. The casters must be attached during unpacking.



CAUTION: Lifting

The Series 2 Portable Chillers are designed to easily roll on casters. If, for some reason you need to lift the chiller, take all precautions to avoid personal injury or damage to the chiller. Lift the chiller using a forklift or hoist with straps that have been positioned at the chillers' center of gravity. Do not try to lift the unit manually.

- 1** Carefully uncrate the chiller and its components.
- 2** Remove all packing material, protective paper, tape, and plastic. Compare contents to the shipping papers to ensure that you have all the parts.
- 3** Carefully inspect all components to make sure no damage occurred during shipping. If any damage is found, notify the shipping agent immediately. Check all wire terminal connections, bolts, and any other electrical connections, which may have come loose during shipping. Check for pinched wires and kinked hoses.
- 4** Cut the bands holding the chiller on the pallet.
- 5** With a forklift lift the chiller high enough to attach the casters, if shipped unattached. Thread the casters into the threaded plates on each corner of the unit.
- 6** Record serial numbers and specifications for the chiller in the blanks provided on the back of the User Guide's title page. This information will be helpful if you ever need service or parts.

WARNINGS AND CAUTIONS



WARNING: Improper installation, operation, or servicing may result in equipment damage or personal injury.

This equipment should only be installed, adjusted, and serviced by qualified technical personnel who are familiar with the construction, operation, and potential hazards of this type of machine.

All wiring, disconnects and fuses should be installed by qualified electrical technicians in accordance with electrical codes in your region. Always maintain a safe ground. Do not operate the equipment at power levels other than what is specified on the machine data plate.



CAUTION: Hot Surfaces

Always protect yourself from hot surfaces when working on the Portable chiller, especially when working on or around the compressor and condenser. These devices can reach up to 160 °F (71 °C). Allow these devices to cool before performing any maintenance or troubleshooting.



CAUTION: Ventilation

The unit requires a clean and well ventilated operating environment. Do not place anything on top of the unit while operating.

Units require enough clearance around the perimeter for access doors to open completely. Air-cooled units require a minimum of two feet clearance around the perimeter for proper air flow.



WARNING: Refrigerant hazard

Only certified refrigerant technicians should examine and correct problems involving the refrigerant circuit.



WARNING: Hazardous substance

When burned, Freon R22 refrigerant forms Phosgene gas. If the chiller is placed in the vicinity of equipment with combustible systems, the combustion air intake must be ducted in from the outside and sealed in such a manner as to prevent any refrigerant from entering the combustion chamber. Refer to the Material Safety Data Sheet for Freon R22 included in the Appendix. This sheet explains the potential hazards and how to avoid them.

PREPARING FOR INSTALLATION

Plan the location for the chiller and prepare the area properly.

Position the chiller as close to the process machine as possible. Place the chiller in position near the process machine so that fluid lines can be connected from the process machine to the chiller and back.

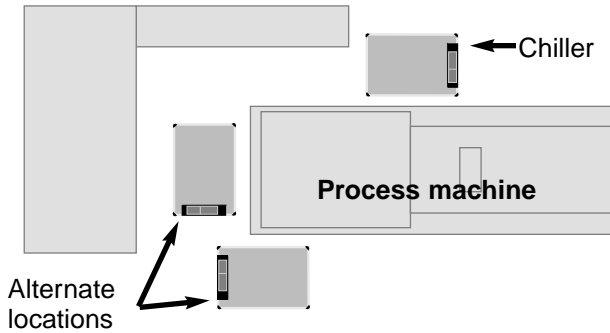

Make sure the area where the chiller is installed has:

- **A grounded power source.**

Check the chiller's serial tag for the correct amps, voltage, phase, and cycle. All wiring should be completed by qualified personnel and comply with your region's electrical codes.

- **Clearance for safe operation and maintenance.**

Make sure there is two feet clearance around the chiller for proper operation. After positioning lock casters to prevent chiller from moving. For maintenance and servicing, be sure there is enough clearance to remove all access panels completely.

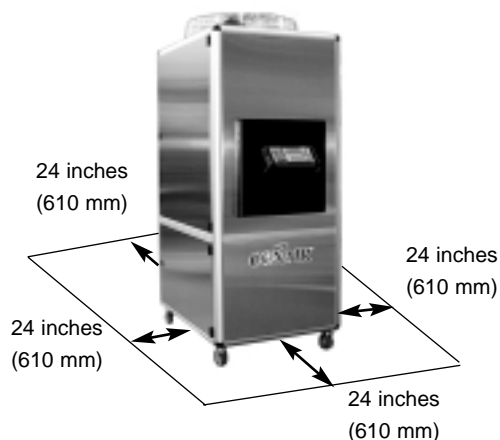

- **Available water source.**

If installing a water-cooled unit, make sure water source is plumbed to chiller installation location. High points in plumbing require vent valves; low points require drain valves.

MAKING PROCESS PLUMBING CONNECTIONS

Warm fluid from process equipment enters the chiller at the From Process valve and chilled fluid returns to the process equipment through the To Process valve.

- 1 Remove the shipping plastic pipe plug from the female connections on the back of the portable chiller.**
- 2 Make sure the male pipe threads are clean and new.**
- 3 Wrap threads with Teflon or pipe dope.**
- 4 Connect the From Process valve on the back of the chiller to the From Process tubing. Start by hand until the threads engage and then tighten with a pipe wrench. Tighten only enough to prevent leaks; do not over-tighten!**
- 5 Connect the To Process valve on the back of the chiller to the return tubing. Start by hand until the threads engage and then tighten with a pipe wrench. Tighten only enough to prevent leaks; do not over-tighten!**

For the Water-cooled Chillers connect the water source for cooling to the Condenser Water inlet on the back of the chiller. Connect the Condenser Water outlet for returning water.

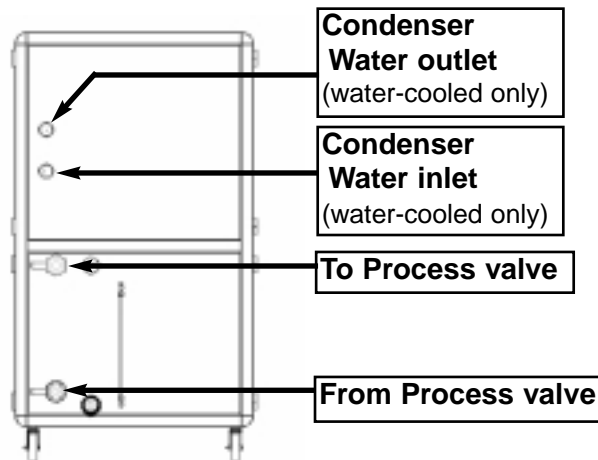

For overhead piping installations, see Overhead Plumbing Details, in the Appendix.

FILLING THE CHILLER

The chiller is shipped without coolant. The chiller is filled manually during installation. Use water as the coolant down to 40 °F (4 °C). Below 40 °F and down to 20 °F (-7 °C), use an ethylene glycol or propylene glycol solution (see % Glycol vs. Temperature chart, next page)..

To fill with water:

- 1** Attach water hose to Fill/Drain valve.
- 2** Close the To Process and From Process valves.
- 3** Open the Fill/Drain valve and fill chiller to the fill mark on the Water Level gauge. If the chiller is overfilled, the excess water spills out the vent tube. DO NOT OVERFILL.
- 4** Close the Fill/Drain valve.
- 5** Check the coolant level.
When the chiller is turned on the coolant level drops as the coolant begins to circulate, filling the connected plumbing. Check the coolant level on the back of the chiller. The coolant level shows on the water level gauge. Make sure coolant level is filled to the mark on the gauge. Add more if needed.
- 6** Disconnect water hose from Fill/Drain valve.

NOTE: If your chiller has the optional auto-fill reservoir, the level switch will automatically fill the reservoir with water as needed.

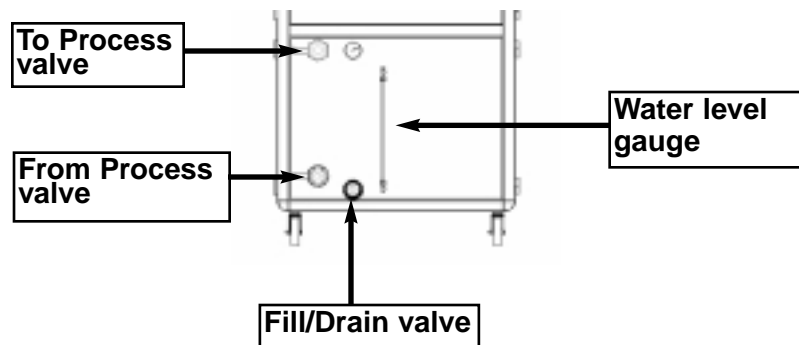

To fill with glycol solution:

FILLING THE CHILLER

CONT'D

- 1 Mix the glycol to the proper percentage.**

Use the table to determine the percentage (by volume) of glycol needed for the process temperature (in °F) you require. Do not choose a temperature below 15 °F (-9 °C). Mix the proper percentage of glycol with water.

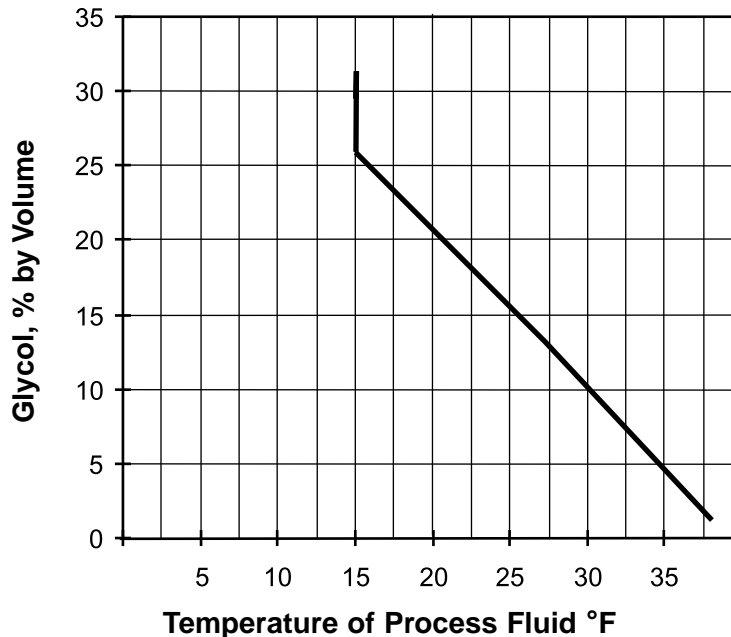

- 2 Close the To Process and From Process valves.**
- 3 Open the Fill/Drain valve and fill chiller**

to the fill mark on the Water Level gauge. If the chiller is overfilled, the excess fluid spills out the vent tube. DO NOT OVERFILL.
- 4 Close the Fill/Drain valve.**
- 5 Check the coolant level.**

The coolant level drops as the coolant begins to circulate and fill the connected plumbing. Check the coolant level on the back of the chiller. The coolant level shows on the water level gauge. Make sure coolant level is filled to the mark on the gauge. Add more if needed.
- 6 Set the Chiller control for 'Percent Glycol'.**

Set the percent glycol using the PLC control (see Setting Percent Glycol, in the Operation section). Do this step after main power is connected to the chiller and initial startup has already been performed.

CHECKING REFRIGERANT CHARGE

All chillers are fully charged with refrigerant at the factory. Your chiller's model nameplate identifies the type and amount of total refrigerant charge required.

Check refrigerant charge while the chiller is running. Check the refrigerant charge through the sight glass. For water-cooled models open the side panel for a short period of time (15 seconds maximum) and check the sight glass; for air-cooled models, locate the sight glass through the wire mesh side panel. Use a flashlight, if necessary, and check the sight glass:

- **Under full load conditions**, the refrigerant should be clear (no bubbles).
- **Under low load conditions**, when the hot-gas bypass valves are operating, bubbles may be visible in the sight glass. This is normal.

If the charge is low and the unit is under warranty, contact Conair service. Otherwise have a local, certified refrigeration technician add refrigerant to the system.



WARNING: Refrigerant hazard

Only certified refrigerant technicians should examine and correct problems involving the refrigerant circuit.



WARNING: Hazardous substance

When burned, Freon R22 refrigerant forms Phosgene gas. If the chiller is placed in the vicinity of equipment with combustible systems, the combustion air intake must be ducted in from the outside and sealed in such a manner as to prevent any refrigerant from entering the combustion chamber. Refer to the Material Safety Data Sheet for Freon R22 included in the Appendix. This sheet explains the potential hazards and how to avoid them.

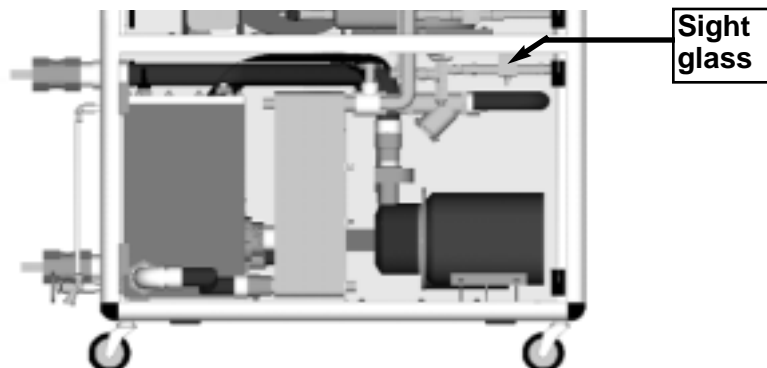

CONNECTING THE MAIN POWER SOURCE



WARNING: Improper installation, operation, or servicing may result in equipment damage or personal injury.

This equipment should only be installed, adjusted, and serviced by qualified technical personnel who are familiar with the construction, operation, and potential hazards of this type of machine.

All wiring, disconnects and fuses should be installed by qualified electrical technicians in accordance with electrical codes in your region. Always maintain a safe ground. Do not operate the equipment at power levels other than what is specified on the machine serial tag and data plate.



WARNING: Electrical hazard

Before performing any work on this item, disconnect and lock out electrical power sources to prevent injury from unexpected energization or startup.

- 1 Open the chiller's electrical enclosure.**
- 2 Connect the power wires to the terminals**
(See the wiring diagrams that came with your machine).
Route the power cable through the hole in the side of the chiller to the electrical enclosure.
- 3 Check terminal screws to make sure wires are secure.** Gently tug each wire; if wire is loose, use a screwdriver to tighten the terminal.
- 4 Connect the ground wire to grounding lug.**

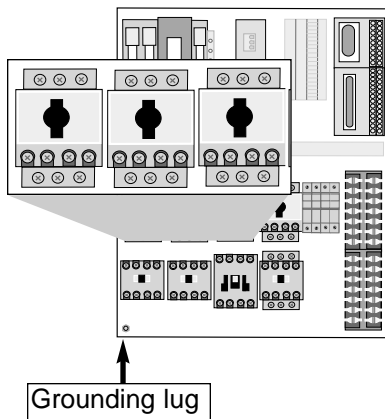

CHECKING ELECTRICAL CONNECTIONS



WARNING: Electrical hazard

Before performing any work on this item, disconnect and lock out electrical power sources to prevent injury from unexpected energization or startup.

- 1 Open electrical enclosure.**
- 2 Check the short-to-ground with an ohm meter.**
Connect the ohm meter to each of the three terminal screws and to the grounding lug. Test all three for resistance. The minimum resistance to ground should be 1 megohm. If its resistance is less than 1 megohm there is a leak in the system.

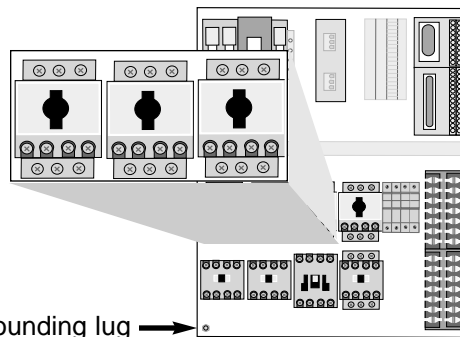

- 3 Close the electrical enclosure.**

The chiller is now ready for initial startup.

If you disconnect the chiller from the main power supply and reconnect it, the chiller needs 15 minutes for the crankcase heater to warm up. You can not use the chiller during this time.

INITIALLY WARMING THE CHILLER

- 1 Turn on main power source.**
The control boots up and when finished, the screen displays the Portable Chiller model number and the six-digit serial number.

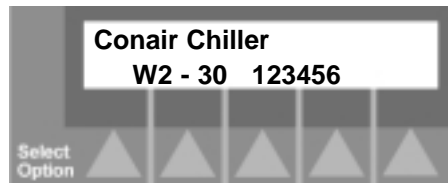

WARNING: Initial startup

Do not press any buttons after initially applying power to the chiller. Let the chiller set, undisturbed, for a minimum of 8 hours before starting the chiller. This is necessary to allow the crankcase heater to warm properly, and to prevent the refrigerant from pooling in the compressor.

CHECKING PUMP ROTATION

After the initial warm up, check for proper pump rotation. If the pump rotation is correct, all other 3-phase components will be in the proper rotation and do not need checked.

Manually turn on the pump from the main screen:

- 1 Press the arrow pointing to Run on the screen.**

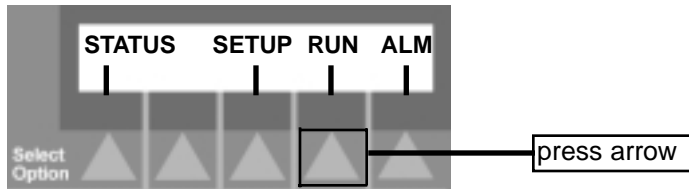

- 2 Use the Scroll arrows to scroll through Run screens to the Manual Pump screen.**

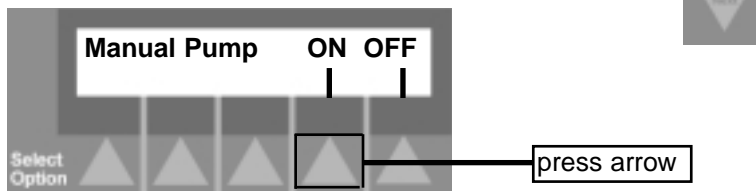

- 3 Press the ON arrow.**

The pump should begin running. Open the chiller cabinet and check the rotation of the pump. The pump should be turning clockwise. If the pump is not turning or is turning counterclockwise, press the Stop Chiller button, disconnect the main power to the chiller and swap any two main incoming wires. Reapply main power to the unit, scroll to the Manual pump screen and again turn on the pump. Pump should now be turning clockwise. If an alarm occurs, see Answering Alarms, in the Troubleshooting section. If alarm continues or reoccurs, call your Conair Service representative.

- 4 Press the Escape/Previous Screen button.**

The control returns to the main screen.



CHECKING FOR LEAKS

After checking pump rotation, continue with startup by checking the chiller for leaks. Do this by turning on only the pump from the control and letting the pump run while checking the inside of the chiller.

- 1 Press the Next arrow on the control to move to the Main screen.**



The Main screen displays:

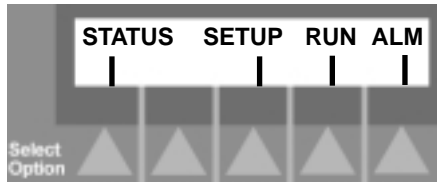

- 2 Press the Run arrow on the screen.**

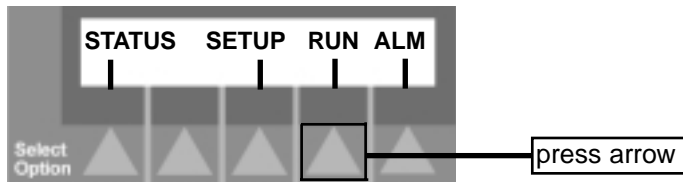

- 3 Press the Scroll arrows to scroll to the Manual Pump screen. The Manual Pump screen displays:**

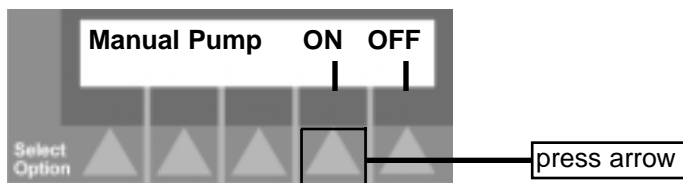

- 4 Press the Pump ON arrow.**
With the pump running check inside the chiller for leaks.

If you find leaks:

- 1 Press the Stop Chiller button on the control panel.**



- 2 Disconnect the chiller from the main power supply and repair any leaks. Dry any moisture inside the chiller.**

- 3 Reconnect the main power supply.**

INITIALLY RUNNING THE CHILLER

Only after you have checked for leaks and checked for pump rotation should you run the chiller. To initially run the chiller, from the main screen:

1 Press the Run arrow.

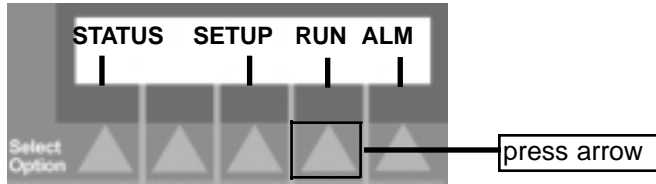

The Run screen displays:

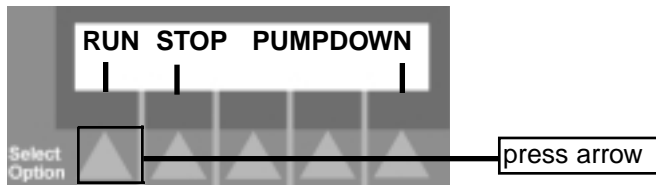

2 Press the RUN arrow.

Verify that the chiller begins to run. Check that the Compressor lights and the Process Pump light on the control panel are lit.

3 If you get an alarm message on the display:

If you get a *Compressor1, 2 Rotation Error* message, press the Stop Chiller button, unplug chiller from main power supply, switch any two incoming main power leads, and apply main power supply. Wait for the required warmup time and then press Run arrow.

4 Press the Escape/Previous button to return to the Main screen.



CONNECTING THE REMOTE CONTROL

If your chiller has the optional remote interface, you need to connect it to the chiller control. If the control is hinged on the bottom. Pull down on the top of the outer bezel of the control to expose the internal wiring. Plug the interface cable from the remote controller into the communication cable connection. Otherwise open the control center and access the communications port on the back of the door.

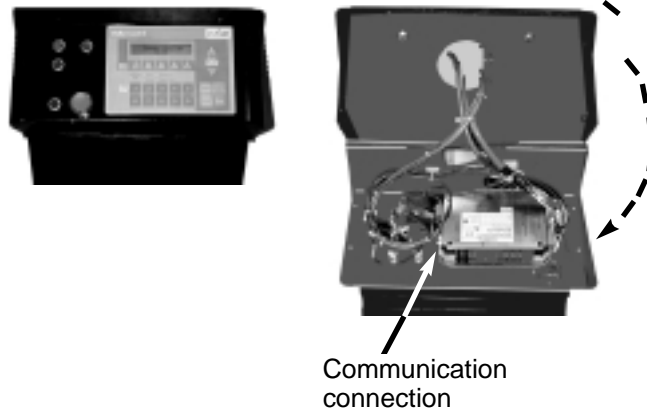

STOPPING THE CHILLER

To stop the chiller, press the Stop Chiller button on the control panel.



The compressor shuts off after a pumpdown and the pump shuts off 10 seconds later. This allows the chiller to pump down the refrigerant system and store the refrigerant in the receiver (water-cooled models) or condenser (air-cooled models). This prolongs the life of the compressor.

NOTE: If you want to restart the chiller immediately after stopping it, pressing the Run arrow on the display starts the pump (the Process Pump light on the control panel lights) but the compressor will not turn on for three minutes. After three minutes the compressor turns on and the Compressor light on the control panel lights. This allows temperatures to lower, making restart easier, and prolonging the life of the compressor.

If the chiller is not working properly at any time, stop the chiller and refer to the Troubleshooting section. If you do not encounter any problems, proceed to the Operation section.

OPERATION

- **PLC Control Features**4-2
- **Before Starting**4-3
- **Powering Up**4-4
- **Running/Stopping the Chiller** .4-5
- **Viewing Chiller Status**4-6
- **Programming Settings**4-8
- **Changing Setpoint**
 - Temperature**4-9
- **Resetting PID Settings**4-10
- **Changing High Temperature**
 - Deviation**4-11
- **Setting Percent Glycol**4-12
- **Setting Fan Setpoints**4-14
- **Selecting the**
 - Temperature Scale**4-15
- **Setting Auto Tune Mode**4-16
- **Setting Discharge**
 - Pressure Setpoint**4-18
- **Selecting PID Values**4-19
- **Manually Starting/
Stopping the Pump**4-20

PLC CONTROL FEATURES

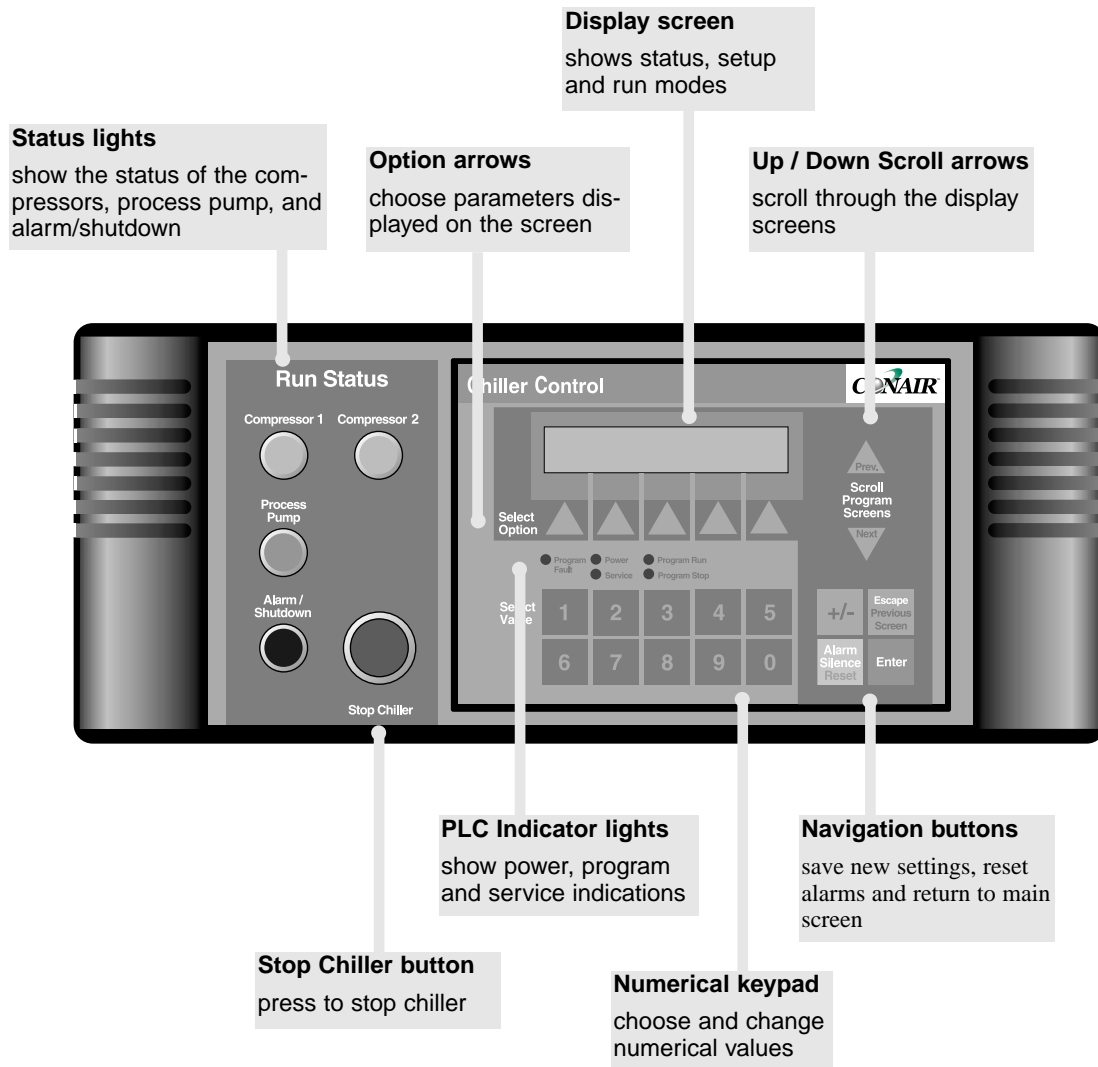

Before you start daily operation of the chiller, you need to perform scheduled preventative maintenance. Necessary maintenance is describe in the Maintenance section of this Users Guide.

BEFORE STARTING



WARNING: Electrical hazard

Be sure that power to the chiller is OFF when doing any maintenance on the chiller. Follow all safety rules when performing any maintenance on this equipment.

Daily maintenance includes:

- **Checking electrical connections**
- **Checking process fluid level in the pump tank**
- **Checking the condenser coil for debris** (air-cooled only)
- **Verifying pump discharge pressure**
- **Inspecting piping for leaks.**

NOTE: The daily, weekly, monthly, and annual maintenance procedures are detailed in the Maintenance section. Go there for the detailed maintenance descriptions.

Before starting the chiller be sure to:

- **Open the To Process valve** to the full open position.
- **Open the From Process valve** to the 3/4 open position. You will need to adjust this valve when the chiller is running to obtain the desired pump discharge pressure. To find the approximate water flow, refer to the pump curves in Description section.
- **Open the supply valve** if the chiller has the optional Auto-fill reservoir.

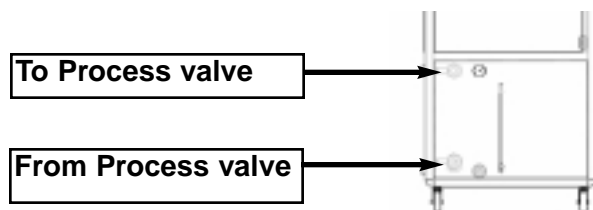

POWERING UP

Plug in the power cord to restore power after any required maintenance. The chiller requires 15 minutes warmup time after it is plugged in for the crankcase heater to warm up.

1 Turn on the main power.

The chiller control automatically performs its bootup routine. The screen displays the Portable Chiller model number along with the serial number

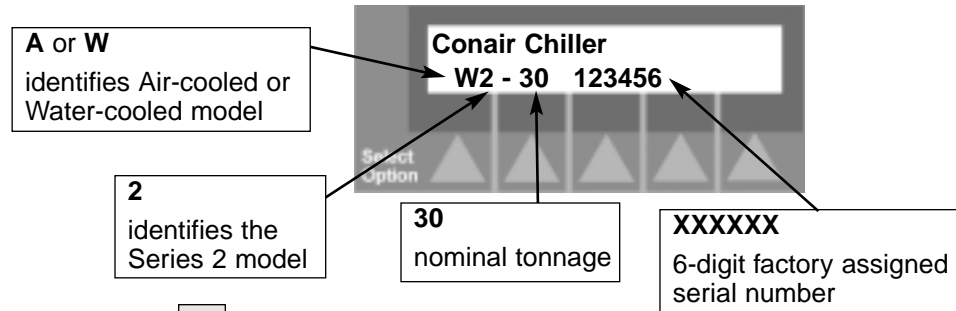

2 Press the Scroll arrow to move to the Main screen.



The main screen displays:

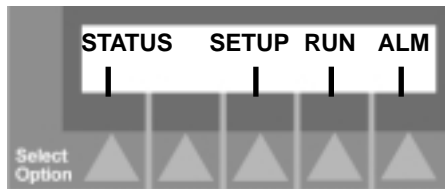

The main screen lets you:

- view the status of the water level, process temperature, process setpoint, suction pressure, percent glycol, low temperature cutout and discharge pressure.
- view and change the setups for temperature setpoint, Auto tune mode, high temperature deviation, and percent glycol solution
- run or stop the chiller
- view alarm information
- perform maintenance with password clearance

3 Press the arrow pointing to the selection you want displayed on the screen.

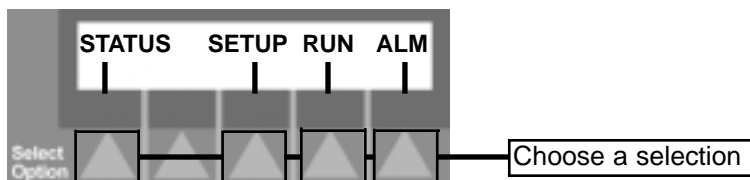

RUNNING/ STOPPING THE CHILLER

After you have viewed all the Status screens and made any necessary changes to the Setup screens, you are ready to run the Chiller. To run the chiller from the main screen:

- 1 Press the Run arrow on the Main screen.**

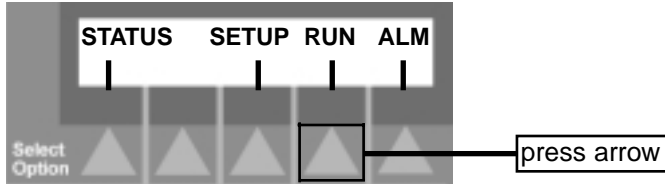

- 2 Press the RUN arrow.**

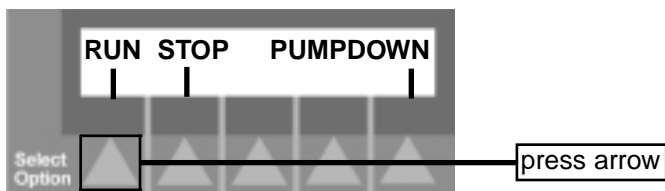

In Run mode the compressor cycles off at 4° below the setpoint if the load is too low for the hot gas to keep the compressor from shutting down. If the compressor shuts down it will not restart until after 3 minutes and only if temperature is at least 1°F above setpoint.

If you want to stop the chiller and continue to run the pump, choose PUMPDOWN.

- 3 Press the Escape/Previous Screen button.**

The control returns to the main screen.



To stop the chiller at any time, press the red Stop Chiller button on the control.



The chiller control and display screen remain on, but the pump and compressor stop.

If you want to restart immediately, the pump will turn on but the compressor will not turn on for three minutes. The Process Pump light on the control panel will light immediately and the compressor light will flash. After three minutes the compressor turns on and the Compressor light on the control panel lights.

VIEWING STATUS SCREENS

The Status button does not let you change the status, only view it.

The Status screens are read-only screens. You cannot make changes to these screens. To view the status screens:

- 1 Press the Status arrow on the Main screen.**

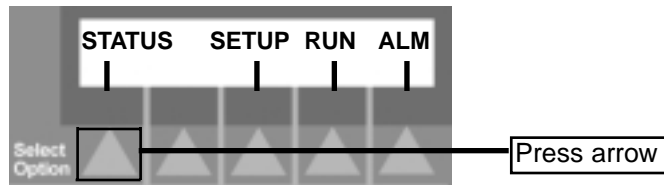

- 2 Use the scroll arrows to scroll through the status screens.**

Verify that the readings each screen displays are the ones you want. You cannot change the readings of the screens from the Status screens. You can change to status of:

- **Setpoint temperature**
- **Percent Ethylene Glycol by volume**

by going to the Setup screens. You can not change the other readings; they are read-only screens, reporting environmental conditions.

- 3 Press the Escape/Previous button at any time to return to the main screen.**

NOTE: Normal setpoint operating range is 40 - 70°F. If glycol is added to the chiller and the percent glycol is entered into the control, the PLC automatically adjusts the setpoint operating range.

VIEWING STATUS SCREENS

CONT'D

Status screens include:

Temperature

Displays the To Process temperature and the Setpoint temperature. To change the Setpoint temperature, go to Changing Setpoint Temperature, in the Operation section.

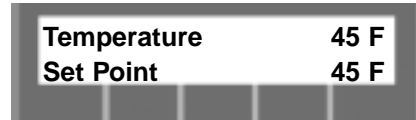

Temperature	45 F
Set Point	45 F

From Process Temp

Shows the temperature of the fluid entering the chiller. Can display in degrees Fahrenheit or Celsius.

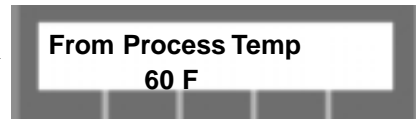

From Process Temp	60 F
-------------------	------

Percent chiller load

Shows the current percent of chiller capacity being used. This percentage is a read-only value and changes as the chiller cycles.

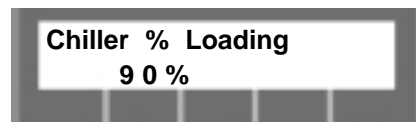

Chiller % Loading	90 %
-------------------	------

Water level

Displays the current water level status. Screen displays Level Okay, or Level Low. If the level is low, see Filling the Chiller, in the Installation section.

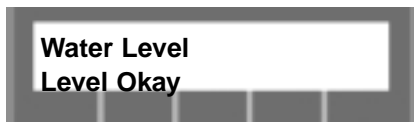

Water Level	Level Okay
-------------	------------

Compressors (for units with dual compressors, 20 ton+)

Displays the activation status of the two refrigeration circuits, compressor 1 and compressor 2. ON is activated; OFF is disabled. Lists In/Out of Service for each.

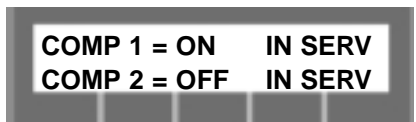

COMP 1 = ON	IN SERV
COMP 2 = OFF	IN SERV

Refrigerant suction pressure

Shows the status of the refrigerant suction pressure in PSIG for compressor(s) 1 and 2, if chiller has dual compressors. NOTE: Typical refrigerant suction pressure is between 55 PSIG and 95 PSIG.

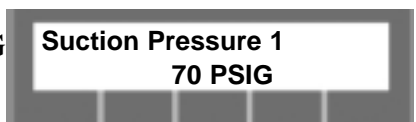

Suction Pressure 1	70 PSIG
--------------------	---------

Refrigerant Discharge pressure

View the status of the refrigerant discharge pressure in PSIG for compressor(s) 1 and 2, if chiller has dual compressors. Typical discharge pressure is between 190 PSIG and 325 PSIG.



Discharge Pressure 2	250 PSIG
----------------------	----------

Percent Ethylene Glycol by Volume and Low Temperature Cutout

Displays the percentage of ethylene glycol or propylene glycol solution (by volume) in the chiller in degrees Fahrenheit. Changing the percent glycol automatically changes the low temperature cutout.

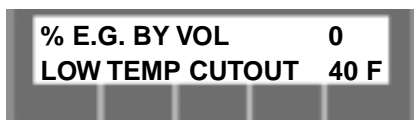

% E.G. BY VOL	0
LOW TEMP CUTOUT	40 F

PROGRAMMING SETTINGS

If you do not need to change any settings on the control, go to Running the Chiller.

The PLC control allows you to program various parameters for the Chiller:

- **Temperature Setpoint**
The temperature you want the To Process liquid.
- **Auto Tune PID**
Helps maintain the temperature setpoint without overshooting.
- **High Temperature Deviation**
Set the number of degrees the temperature can rise above the setpoint temperature without an alarm.
- **Percent Glycol by Volume**
Use when you use an ethylene glycol or propylene glycol solution to lower the To Process temperature. Changing the percent glycol automatically changes and displays the low temperature cutout, in °F.
- **Fans (Air-cooled only)**
Set the upper and lower temperatures for the fans to cycle. This screen is password protected.
- **Maintenance**
View times for compressor cycle, pump run time, pump cycle and hot gas bypass cycle. These screens are password protected.

To program settings from the Main screen:

- 1 Press the Setup arrow.**

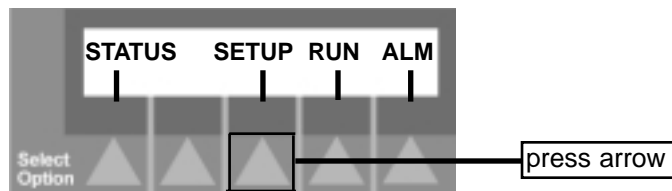

The first Setup screen displays:

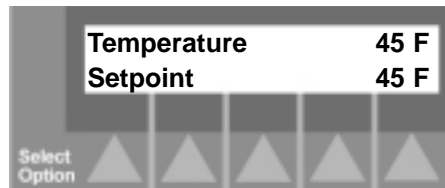

- 2 Press the Up and Down Scroll arrows to scroll through the Setup screens. Stop at the one you want to change.**



CHANGING SETPOINT TEMPERATURE

Use the Temperature Setpoint to set the temperature you want the water to be exiting the chiller at the To Process valve.

To display the Setpoint temperature from the Main screen, press the Setup arrow. The Setpoint screen displays:

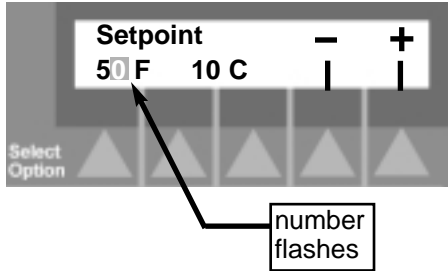

The current setpoint temperature displays in both Fahrenheit (F) and Celsius (C). The temperature in °F flashes.

- 1 Press the arrows to change the setpoint** temperature. Pressing the (-) arrow lowers the temperature by one degree; pressing the (+) arrow increases the temperature by one degree. Pressing the arrows automatically changes both scales.

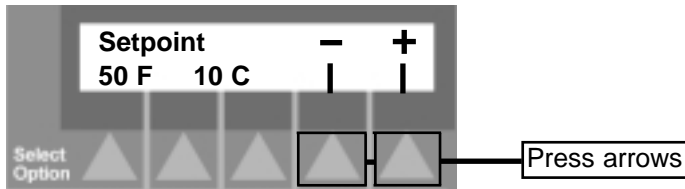

OR

Use the numeric keypad

to set the temperature setpoint. Press the numbers for the temperature you want, then press the Enter button to save.



- 2 Press the scroll arrows to move to the next** setup screen, or press Escape/ Previous Screen button to return to the main screen.



RESETTING PID SETTINGS

Use the PID reset to return the control to the factory settings. Use this if the autotune does not give good values or good values are lost.

To reset PID from the main screen:

- 1 Press the Setup arrow.**

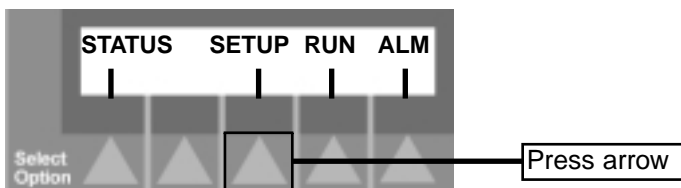

- 2 Press the Scroll arrows to scroll through the Setup screens. Stop when you get to the PID Reset screen. Use this screen to reset the PID controls, set the discharge pressure setpoint (DPS) for water-cooled chillers, and to set the on/off discharge pressure setpoints for the air-cooled chillers with the VFD option.**



- 3 Press the PID Reset arrow.**

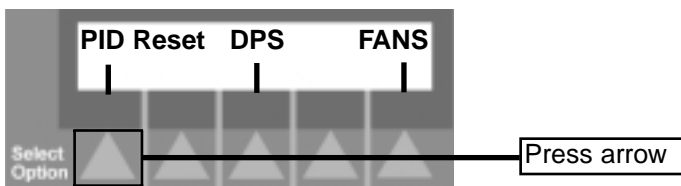

- 4 Press the scroll arrows to move to the next setup screen, or press Escape/ Previous Screen button to return to the main screen.**



CHANGING HIGH TEMPERATURE DEVIATION

Decide how many degrees above the setpoint you want the chiller to deviate before an alarm occurs.

To set the high temperature deviation:

1 Press the Setup arrow.

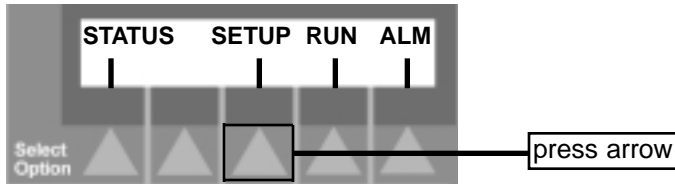

Continue to press the arrow to scroll through the Setup screens. Stop when you get to the High Temp Dev screen. The current high temperature deviation number displays along with the - and +. The number flashes on the screen.

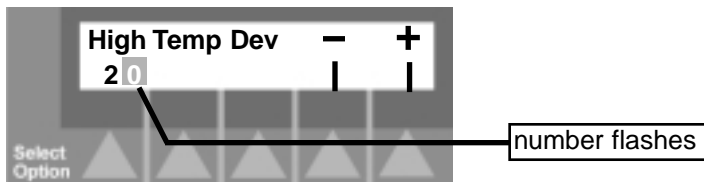

2 Press the - or + arrows to set the high

deviation to the appropriate number. Each press of the (-) arrow decreases the high deviation by one unit; each press of the (+) arrow increases the high deviation by one unit. Stop when you reach the number you want. The allowable range is 3 - 20°F.

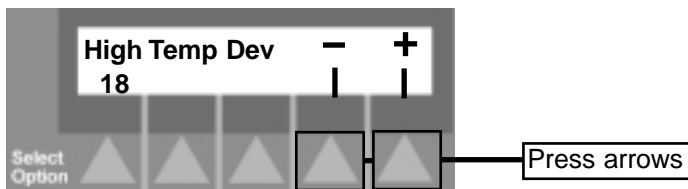

OR

Use the numeric keypad to enter the number for the high deviation. After using the keypad press the Enter button to save.

3 Press the Scroll arrows to scroll to the next Setup screen, or press the Escape/Previous Screen button to return to the main screen.



SETTING PERCENT GLYCOL

To set the percent ethylene glycol or propylene glycol solution determine the temperature of the process fluid you want.

Use water as the coolant for chilling the process fluid down to 40°F (4°C). Below 40°F and down to 20°F (-7°C), use a glycol solution.

Use the table to choose the proper percentage of glycol solution for the required temperature.

NOTE: If you are using water as the coolant, set the Percent Glycol to zero on the control.

This screen is password protected. You must have clearance to enter and change this setting.

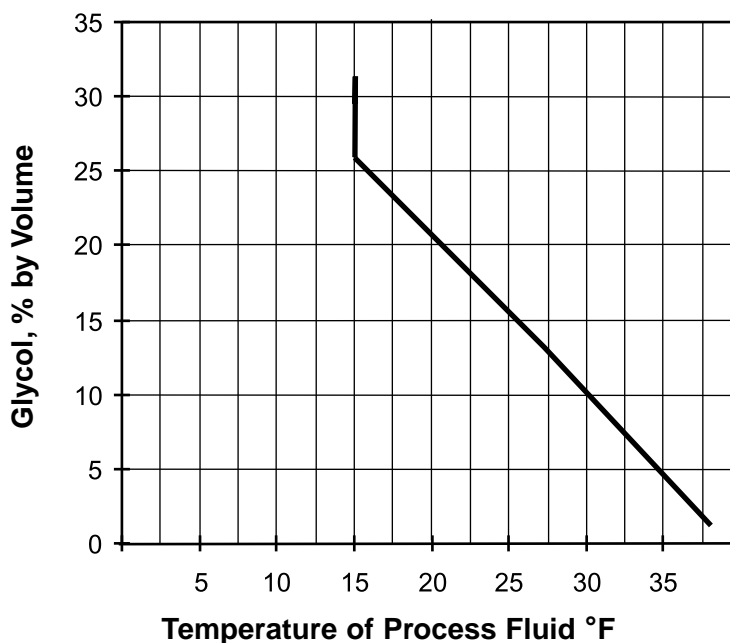

After choosing the temperature you want, mix the glycol solution to the proper percentage and fill the chiller according to the directions in Filling with Glycol Coolant, in the Installation section.

Program the percentage glycol solution into the control. From the main screen:

1 Press the Setup arrow.

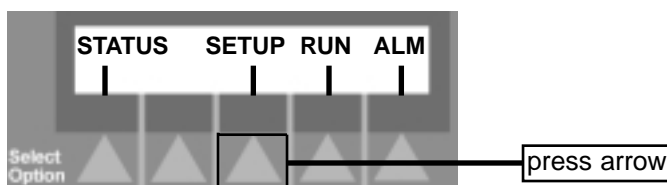

SETTING PERCENT GLYCOL CONT'D

- 2** Press the Up/Down Scroll arrows to scroll through the setup screens.

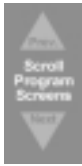

Stop when you get to the Percent Glycol screen:

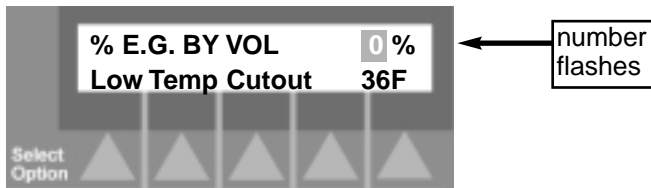

The screen displays the percent of glycol by volume currently used. This number is flashing. The screen also displays the low temperature cutout (If the To Process fluid drops below this temperature, an alarm condition occurs and the compressor shuts off.)

NOTE: If you are using water as the coolant, set the Percent Glycol to zero on the control.

- 3** Use the numeric keypad to set the percent glycol. Make sure the percent you enter is the same as the percent mixture you added to the chiller. See Filling the Chiller, in the Installation section.



NOTE: This screen has password protection. You can change the percent glycol only if you have clearance. A screen displays: **\$316 Password level invalid...** The password screen then displays, asking for the password. Enter the password (999). You now have password access for five minutes. Otherwise, press the Escape button to return to the Main screen.

- 4** Press the Scroll arrows to scroll to the next Setup screen, or press the Escape/Previous Screen button to return to the main screen.



SETTING FAN SETPOINTS

For the Air-cooled Portable Chillers you can choose the condenser pressures in PSIG at which the fan cycles on and off. To set the Fan Setpoints from the main screen:

- 1 Press the Setup arrow.

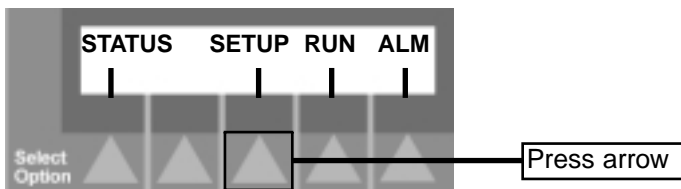

- 2 Press the Scroll arrows to scroll through the Setup screens. Stop when you get to the PID Reset screen.

This screen is password protected. You must have clearance to enter and change this setting.

- 3 Press the Fans arrow.

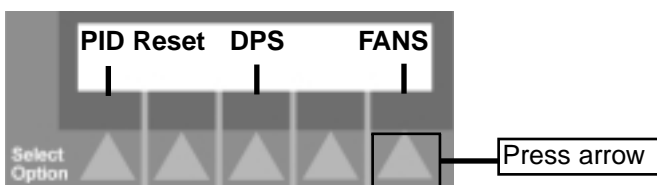

A screen displays asking for the password. Use the Keypad to enter the password (999) and then press the Enter button. The Fan Setpoint screen displays:

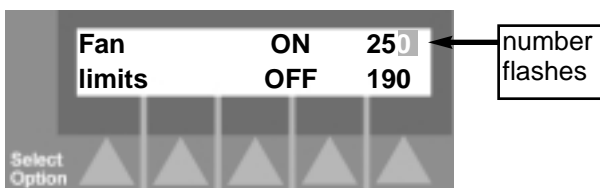

The screen shows the upper and lower condenser pressure limits for the fan. The ON pressure flashes. Use the keypad to change this number. Then press Enter button to save the new number.

- 4 Press the Scroll arrow to move to the OFF setting. The OFF number flashes:

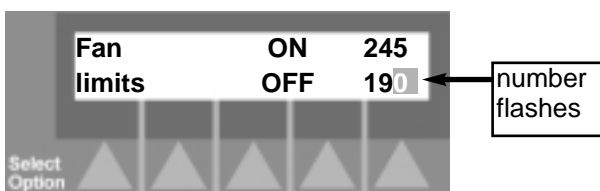

Use the keypad to change the OFF number.

-
- 5** Press Enter to save the change.



- 6** Press the Escape/Previous Screen button to return to the main screen.



Fan setpoints are not saved in retentive memory and are lost when power is disconnected. Factory default values are reloaded on power up.

SETTING FAN SETPOINTS

CONT'D

You can choose to display the temperature in either Fahrenheit or Celsius. To select the temperature scale:

- 1** Press the Setup arrow.

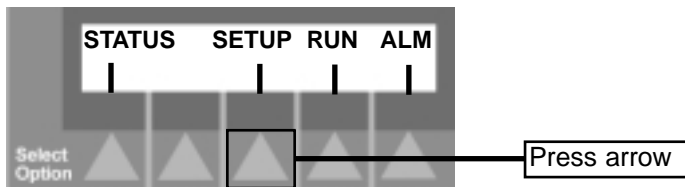

- 2** Press the Scroll arrows to scroll through the Setup screens. Stop when you get to the Select Scale screen. The current choice is listed.

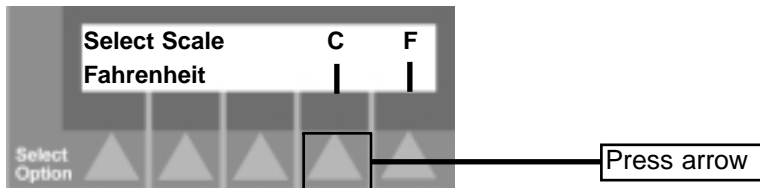

- 3** Press the arrow for the scale you want, F or C. Note that the High Temperature Deviation value and the Alarm History Temperatures are displayed in Fahrenheit scale regardless of which scale is selected on this screen.

SELECTING THE TEMPERATURE SCALE

SETTING AUTO TUNE MODE

Use the Auto Tune Mode to maintain the temperature setpoint and minimize overshooting it. To set Auto Tune the chiller must be in Run mode. To run the Chiller from the main screen:

- 1 Press the Run arrow on the Main screen.**

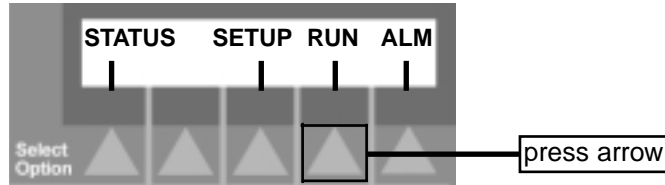

This screen is password protected. You must have clearance to enter and change settings on this screen.

- 2 Press the RUN arrow.**

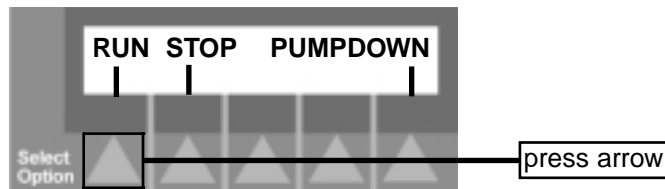

- 3 Press the Escape/Previous Screen button.**
The control returns to the main screen.

To display the Auto Tune Mode from the main screen:

- 1 Press the Setup arrow.**

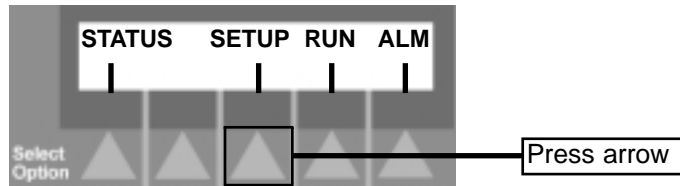

- 2 Press the Scroll arrows to scroll to the Maintenance screen.**



- 3 Press the Maintenance arrow.**



SETTING AUTO TUNE MODE

CONT'D

The password screen displays.

- 4 Use the keypad to enter the password.**
The factory-set password is 999.



- 5 Press the Enter button to enter the password.**



- 6 Press the Scroll arrows to scroll to the Tune screen.**



- 7 Press the Tune arrow.**

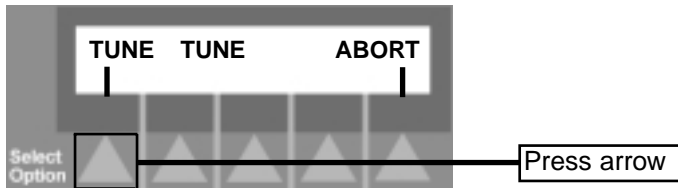

When the control begins tuning the screen displays TUNING message. The auto-tuning sequence takes about 15 seconds. The screen displays the 'TUNE Tuning' message. When tuning is complete, the screen displays the TUNE message. Press the Abort arrow to stop the auto-tuning sequence and return to the last good PID values.

- 8 Press the Escape/Previous Screen button**
to exit the Maintenance screens and return to the main screen.



SETTING DISCHARGE PRESSURE SETPOINT

You can select the discharge pressure setpoints in PSIG. To set the discharge pressure setpoints from the main screen:

- 1 Press the Setup arrow.**

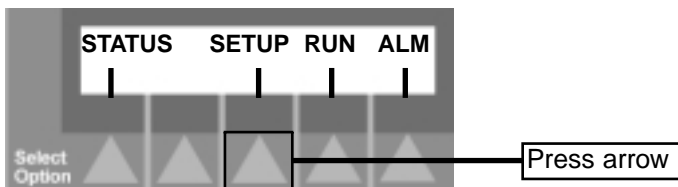

- 2 Press the Scroll arrows to scroll through the Setup screens. Stop when you get to the PID Reset screen.**

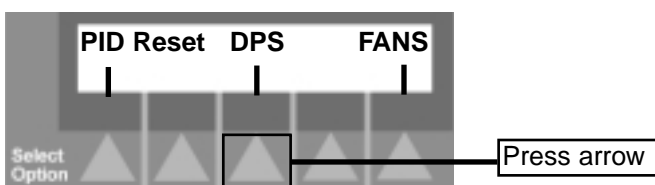

- 3 Press the DPS arrow.**
The Discharge Pressure Setpoint screen displays.

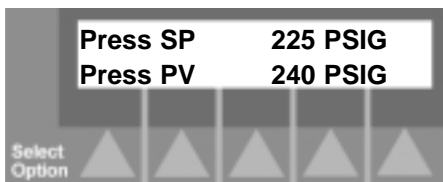

The pressure setpoint (SP) and the pressure process variable (PV), both in PSIG, are listed. Change the value of the pressure setpoint by entering the new number with the Select Value buttons.



The discharge pressure can be set between 100 and 350 PSIG.

- 4 Press the Enter button to accept the new value.**



SELECTING PID VALUES

The PID values are set at the factory to default settings. The values should be changed only if the water regulator valve or the VFD are unable to maintain discharge pressure. To set the discharge pressure setpoints from the main screen:

- 1 Press the Setup arrow.**

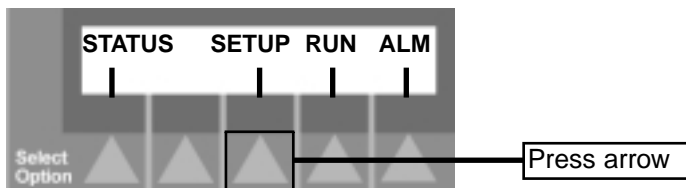

- 2 Press the Scroll arrows to scroll through the Setup screens. Stop when you get to the PID Reset screen.**

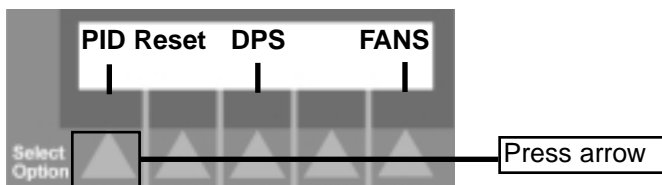

- 3 Press the PID Reset arrow.**

The PID values for Gain and Reset time display. The gain is dimensionless (i.e. has no units) and the intergral value, or Reset time, is measured in seconds. There are no upper or lower limits for these settings.



Use the Select Values buttons to change the gain and reset.



- 4 Press the Enter button to accept the new value. If the PID values need to be restored to the factory default settings scroll to the Reset Factory PID screen from the Setup screen.**

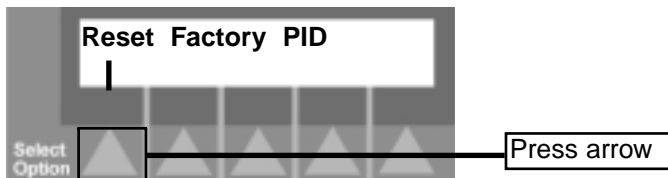

Press the Reset arrow. Gain restores to 2 and Reset restores to 180 seconds.

MANUALLY STARTING/ STOPPING THE PUMP

To run or stop the pump from the main screen:

- 1 Press the arrow pointing to Run on the screen.**

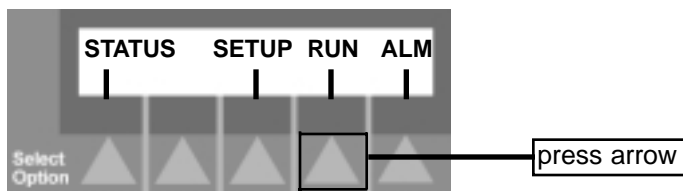

The first Run screen displays.

- 2 Use the Scroll arrows to scroll through Run screens to the Manual Pump screen.**



- 3 Press the arrow pointing to your choice.**
If the pump is running and you want to stop it, press the arrow pointing to Off. Alternate: pressing red extended head button stops the pump if that is all that is running. If the pump is stopped and you want to run it, press the arrow pointing to On.

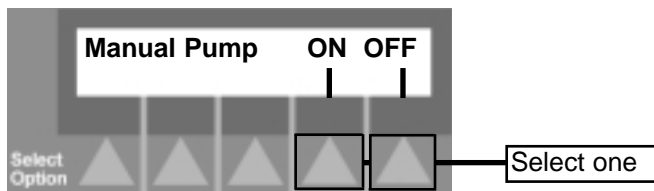

- 4 Press the Escape/Previous Screen button.**
The control returns to the main screen.



MAINTENANCE

- **Maintenance Features5-2**
- **Warnings and Cautions5-3**
- **Preventative Maintenance**
 - Schedule5-4**
- **Entering Maintenance Screens .5-6**
- **Viewing Cycle Screens5-7**
- **Placing Compressors into**
 - Service5-8**
- **Checking Electrical**
 - Connections5-9**
- **Cleaning the Evaporator or**
 - Water-cooled Condenser5-10**
- **Cleaning the Air-cooled**
 - Condenser5-11**
- **Checking the Refrigerant**
 - Charge5-12**
- **Checking Reservoir Level5-13**

MAINTENANCE FEATURES

Conair Series 2 Portable Chillers need regular, scheduled maintenance for peak performance.

To maintain the best performance of the chiller, it must be cleaned and inspected regularly. Maintenance includes a daily, monthly, and semi-annual schedule.

Use this maintenance schedule as a guide. You may need to shorten the time of the maintenance schedule, depending on how often you use the chiller. Among the features that require preventative maintenance are:

- the refrigerant system
- electrical cables, terminals, and control lights
- the condenser, condenser filter strainer at inlet
- caster locks
- temperature and pressure readings
- process fluid level
- efficiency
- evaporator, filter strainer at evaporator inlet
- cooling water treatment system (if used)

Follow all cautions and warnings when working on the equipment.

WARNING AND CAUTIONS



WARNING: Improper installation, operation, or servicing may result in equipment damage or personal injury.

This equipment should only be installed, adjusted, and serviced by qualified technical personnel who are familiar with the construction, operation, and potential hazards of this type of machine.

All wiring, disconnects, and fuses should be installed by qualified electrical technicians in accordance with electrical codes in your region.



WARNING: Electrical hazard

Before performing any work on this item, disconnect and lock out electrical power sources to prevent injury from unexpected energization or startup. Be sure that power to the chiller is OFF when doing any maintenance on the chiller. Follow all safety rules when performing any maintenance on this equipment.



CAUTION: Hot Surfaces

Always protect yourself from hot surfaces when working on the Portable Chiller, especially when working on or around the compressor and condenser. These devices can reach up to 160 °F (71 °C). Allow these devices to cool before performing any maintenance or troubleshooting.



WARNING: Refrigerant hazard

Only certified refrigerant technicians should examine and correct problems involving the refrigerant circuit.



WARNING: Hazardous substance

When burned, Freon R22 refrigerant forms Phosgene gas. If the chiller is placed in the vicinity of equipment with combustible systems, the combustion air intake must be ducted in from the outside and sealed in such a manner as to prevent any refrigerant from entering the combustion chamber. Refer to the Material Safety Data Sheet for Freon R22 included in the Appendix. This sheet explains the potential hazards and how to avoid them.

PREVENTATIVE MAINTENANCE SCHEDULE

To maintain the best performance, follow the maintenance schedule and record information in the Maintenance Log in the Appendix.

● Daily, or as often as needed

- Checking process fluid level in the pump tank**
Check the process fluid level in the water level gauge on the back of the chiller. If low, see Filling the Chiller, in the Installation section.
- Verifying pump discharge pressure**
While the pump is running, check that the pump pressure gauges are within range. To change the pressure open or close the From Process valve.
- Inspecting piping for leaks**
Check to see that pipes are not leaking. Look for standing water on the floor or inside the chiller cabinet.
- Inspecting the condenser coil for debris**
(air-cooled models only). Remove the wire mesh side panel in front of the condenser coil. Remove any debris from the coils.

● Weekly, or as often as needed

- Checking temperature and pressure readings**
Check that the temperature and pressure display on the control screen, and that the pressure gauge indicates normal operation.
- Checking efficiency**
Review the performance data on the Maintenance Log found in the Appendix. If you notice a decrease in efficiency over time, check all heat transfer surfaces of the evaporator and condenser for fouling. Clean as needed.
- Checking refrigerant site glass**
There should not be any bubbles. See Checking Refrigerant Charge, in the Maintenance section.
- Checking reservoir level**
Check the water level gauge on the back of the chiller. If fluid level is low, fill. See Checking Reservoir Level, in the Maintenance section.

● Monthly

- Inspecting cooling water treatment system**
If your chiller uses a cooling water treatment system, maintain proper chemical levels and follow the recommendations of your water treatment specialist. Change water in the reservoir tank monthly.

PREVENTATIVE MAINTENANCE SCHEDULE

- ❑ **Checking electrical connections, amps, volts**
Make sure electrical connections are properly seated. See Checking Electrical Connections, in the Maintenance section. Check fan, compressor, and pump amps and volts.
- ❑ **Cleaning**
Wipe all external surfaces to maintain performance.
- ❑ **Inspecting condenser**
Check the condenser for adequate air flow or water flow. Check the condenser face for dirt and clogging. If dirt or clogs are present, clean the condenser. See Cleaning the Evaporator or Water-cooled Condenser, and Cleaning the Air-cooled Condenser, in the Maintenance section. If your unit has an optional filter at the air inlet of the Air-cooled condenser coil, check, clean, and replace as needed.
- ❑ **Inspecting the control panel**
Check for loose wires, burned contacts, and signs of overheated wires. Check that all panel lights illuminate. See Checking Electrical Connections section.
- ❑ **Checking refrigerant charge**
With the compressor running, check the sight glass between the receiver and evaporator for proper refrigerant condition. See Checking Refrigerant Charge, in the Maintenance section.
- ❑ **Cleaning process fluid strainer**
Remove cap and clean any debris out of strainer. Replace cap.
- **Annually**
 - ❑ **Cleaning the evaporator or water-cooled condenser**
See Cleaning the Evaporator or Water-cooled Condenser, in the Maintenance section.

To maintain the best performance, follow the maintenance schedule and record information in the Maintenance Log in the Appendix.

ENTERING MAINTENANCE SCREENS

The Maintenance screens are password protected. You must have clearance to enter and change settings on these screens.

If the control buttons are not used for 5 minutes, the PLC defaults to the Temperature/Setpoint screen. You must then re-enter the password to use the Maintenance screens.

Use the Maintenance screens to view cycling information. The cycle screens display the total cycles or hours since the initial assembly of the chiller. These numbers are only reset through the Conair screens by Conair Service personnel. To view the cycle information:

1 Press the Setup arrow.

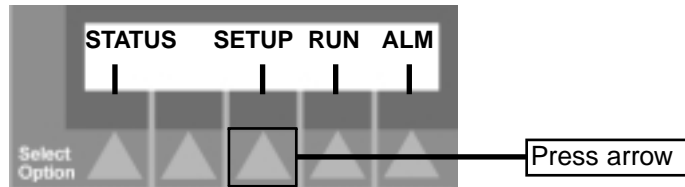

2 Press the Scroll arrows to scroll through the Setup screens. Stop when you get to the Maintenance screen:



3 Press the Maintenance arrow.

The password screen displays. Use the keypad to enter the maintenance password, 999, then press the Enter button.

4 Scroll through the Maintenance screens.

They include:

- **Cycle screens** - view the cycle times for chiller components
- **Tuning screens** - initiate PID auto tune sequence for the hot gas bypass control for the compressor
- **Compressor service screen** - (dual compressor models only) choose the lead compressor (1 by default), and take a compressor in or out of service (IN by default)
- **Conair factory screen** - (unavailable to user)



5 Press the Escape/Previous Screen button

to exit the Maintenance screens and return to the main screen. The password stays in effect for 5 minutes after using it; after 5 minutes the screens return to the User level.



VIEWING CYCLE SCREENS

The Cycle screens show cycle times (in hours) for various components of the chiller. From the Maintenance screen scroll to the Cycles screen. Press the arrow to view the first Cycles screen. Use the Scroll arrows to scroll through the Cycle screens.



Press the arrow to view the cycle screens:

Compressor 1, 2 Run Time

Displays the total time the compressor has been running (in hours, rounded down to the lower hour). Screen will list Compressor 1 or Compressor 2 for dual compressor models. For single compressor models, no compressor number is displayed.



Compressor 1, 2 Cycles

Shows the number of times the compressor (1 or 2 for dual compressor models) has been started

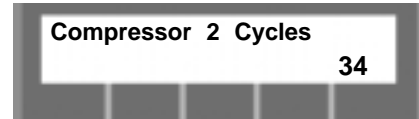

Pump Run Time in hours

Shows the length of time the pump has run in hours.



Pump Cycles

Displays the number of times the pump (1 or 2 for dual compressor models) has been started.

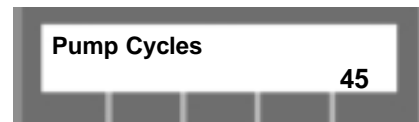

Hot Gas Bypass 1, 2 Cycles

Displays the number of times that the hot gas bypass valve for each compressor opens. This screen does not display for single compressor models.

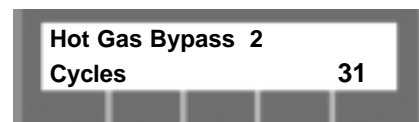

Fan Runtime in Hours

View the number of hours the fan runs. (For air-cooled models only.)



Fan Cycle

Displays the number of times the fan cycles. (For air-cooled models only.)



Press the Escape/Previous Screen button to exit the Cycle screens and return to the main screen. The password stays in effect for 5 minutes after using it; after 5 minutes the screens return to the User level.

PLACING COMPRESSORS IN SERVICE

The Compressor Service screen allows you to place a compressor in or out of service (dual compressor models only). From the Maintenance screen scroll to the Service screen.

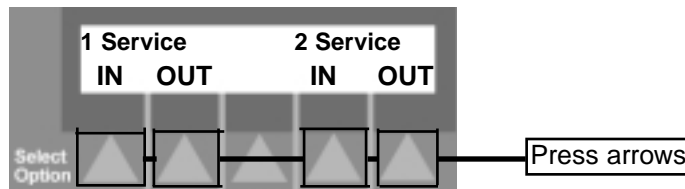

Press the arrows to take compressor 1 and compressor 2 in and out of service.

Press the Escape/Previous Screen button to exit the Cycle screens and return to the main screen. The password stays in effect for 5 minutes after using it; after 5 minutes the screens return to the User level.



**WARNING: Electrical hazard**

Before performing any work on this item, disconnect and lock out electrical power sources to prevent injury from unexpected energization or startup.

**WARNING: Improper installation, operation, or servicing may result in equipment damage or personal injury.**

This equipment should only be installed, adjusted, and serviced by qualified technical personnel who are familiar with the construction, operation, and potential hazards of this type of machine.

All wiring, disconnects, and fuses should be installed by qualified electrical technicians in accordance with electrical codes in your region.

CHECKING ELECTRICAL CONNECTIONS

- 1 Be sure the main power is disconnected** and the chiller is locked out. Always disconnect and lock-out the main power source before opening the unit for servicing.
- 2 Open the electrical enclosure.**
- 3 Inspect all wires and connections.**
Look for loose wires, burned contacts, and signs of overheated wires. Compare the PLC wiring to the wiring diagrams you received with your chiller. Have a qualified electrician make any necessary repairs or replacements.
- 4 Close the electrical enclosure door.**
- 5 Inspect the exterior power cords.**
Cords should not be crimped, exposed, or rubbing against the frame. If the main power cord runs along the floor, make sure it is positioned where it could not rest in pooling water or could not be run over and cut by wheels or casters.

Always refer to the wiring diagrams you received with your chiller to locate specific electrical components.

CLEANING THE EVAPORATOR OR WATER-COOLED CONDENSER

Minerals and other contaminants produce deposits, scales, slime, or algae on the heat transfer surfaces exposed to water. Fouled surfaces result in decreased cooling capacity. Implement a water treatment program to slow the fouling.



CAUTION: Hot Surfaces

Always protect yourself from hot surfaces when working on the Portable Chiller, especially when working on or around the compressor and condenser. These devices can reach up to 160 °F (71 °C). Allow these devices to cool before performing any maintenance or troubleshooting.

Water quality should be maintained at a pH of 7.4, but not less than 6.0 for proper heat exchanger life.

To clean:

- 1 Prepare a 5% solution of Phosphoric acid or Oxalic acid.** Do not heat the acid solution.
- 2 Shut the From Process valve.**
- 3 Disconnect the pump from the heat exchanger.** Install a cap in the opening of the heat exchanger where the pump was connected.
- 4 Connect 1/2-inch tubing to the 1/2-inch connections of the heat exchanger.**
- 5 Back-flush the solution through the heat exchanger and the chiller.**
- 6 Flush the heat exchanger and the chiller piping with fresh water after cleaning.**
- 7 Reconnect the chiller pump to the heat exchanger.** Remove the cap in the heat exchanger and reconnect the hose from the pump.

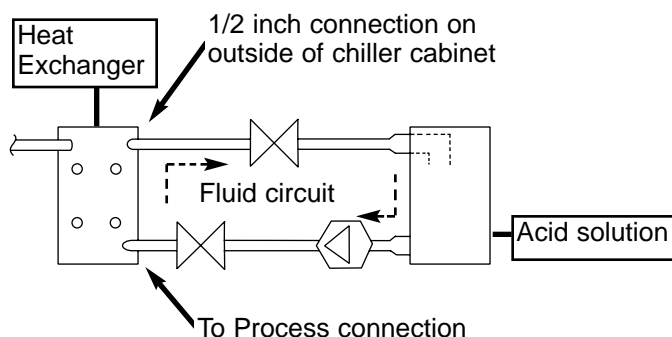
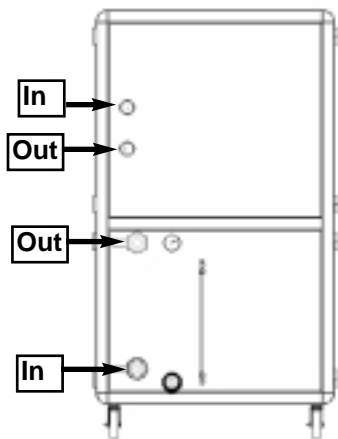

**WARNING: Electrical hazard**

Before performing any work on this item, disconnect and lock out electrical power sources to prevent injury from unexpected energization or startup.

**CAUTION: Hot Surfaces**

Always protect yourself from hot surfaces when working on the Portable Chiller, especially when working on or around the compressor and condenser. These devices can reach up to 160°F (71°C). Allow these devices to cool before performing any maintenance or troubleshooting.

CLEANING THE AIR-COOLED CONDENSER

The air-cooled condenser can accumulate dirt and clog quickly if it is run in a dusty or dirty environment. A clogged condenser increases refrigerant discharge pressure, lowers performance, and may cause the fan motors and compressor to overheat.

- 1 Inspect the coils.**
Use a flashlight to check between coil surfaces.
- 2 Clean the dirty coils with a soft brush.**
- 3 Flush with cool water or a commercial coil cleaner that is compatible with aluminum alloys.**

If your unit has the optional air filter supplied by Conair, clean it using water or air. Replace as needed.

CHECKING THE REFRIGERANT CHARGE

All chillers are fully charged with refrigerant at the factory. Your chiller's model nameplate identifies the type and amount of total refrigerant charge required.



WARNING: Refrigerant hazard

Only certified refrigerant technicians should examine and correct problems involving the refrigerant circuit.



WARNING: Hazardous substance

When burned, Freon R22 refrigerant forms Phosgene gas. If the chiller is placed in the vicinity of equipment with combustible systems, the combustion air intake must be ducted in from the outside and sealed in such a manner as to prevent any refrigerant from entering the combustion chamber. Refer to the Material Safety Data Sheet for Freon R22 included in the Appendix. This sheet explains the potential hazards and how to avoid them.

Check refrigerant charge while the chiller is running. Check the refrigerant charge through the sight glass. Use a flashlight, if necessary, and check the liquid-line sight glass:

- **Under full load conditions**, the refrigerant should be clear (no bubbles).
- **Under low load conditions**, when the hot-gas bypass valves are operating, bubbles may be visible in the sight glass. This is normal.

If the charge is low and the Chiller is under warranty, contact Conair service; or have a local, certified refrigeration technician add refrigerant to the system.

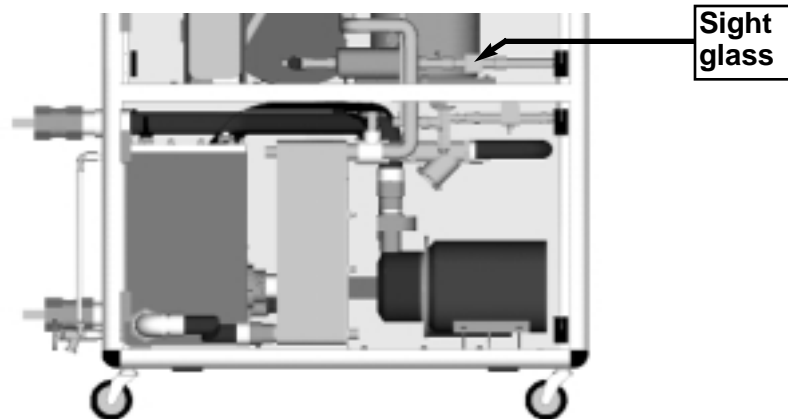



WARNING: Electrical hazard

Before performing any work on this item, disconnect and lock out electrical power sources to prevent injury from unexpected energization or startup.

CHECKING RESERVOIR LEVEL

Check the fluid level in the reservoir. The meniscus in the sight glass on the back of the chiller should be in line with the mark on the sight glass.

To manually fill the reservoir:

1 Disconnect and lockout power to the chiller.

2 Locate the fill/drain valve on the back of the chiller.

3 Refill the reservoir.

Monitor the level using the water level gauge on the back of the chiller. Because the Portable Chiller can use either pure water or a glycol solution, make sure you are adding the correct fluid for your application.

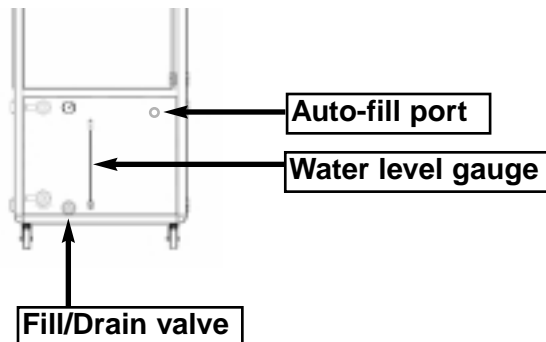

If you have the optional make-up water level float switch, it will automatically control the fluid level.

TROUBLESHOOTING

- *Before Beginning*6-2
- *A Few Words of Caution*6-3
- *Identifying the Cause of a Problem*6-3
- *Answering Alarms*6-4
- *Alarm Conditions*6-5
- *Alarm Errors*6-8
- *Alarm History Screens*6-9
- *Alarm Screen Legend*6-10
- *Control Problems*6-11
- *Alarm Conditions*6-13
- *Checking and Replacing Switches*6-32
- *Checking the Pressure Transducer*6-33
- *Replacing the RTD*6-34
- *Checking the Temperature Transmitter and RTD*6-35
- *Replacing the Temperature Transmitter*6-37
- *Removing Pump Components* .6-38
- *Replacing Overload Modules* .6-39
- *Replacing the Contactor*6-40
- *Replacing the PLC*6-41

BEFORE BEGINNING

You can avoid most problems by following the recommended installation, operation and maintenance procedures outlined in this User Guide. If you have a problem, this section will help you determine the cause and tell you how to fix it.

Before you begin troubleshooting:

- Find any wiring, piping, and assembly diagrams that were shipped with your equipment. These are the best reference for correcting a problem. The diagrams will note any custom features or options not covered in this User Guide.
- Verify that you have all instructional materials related to the chiller. Additional details about troubleshooting and repairing specific components are found in these materials.
- Check that you have manuals for other equipment connected in the system. Troubleshooting may require investigating other equipment attached to, or connected with the chiller.



WARNING: Improper installation, operation, or servicing may result in equipment damage or personal injury.

This equipment should only be installed, adjusted, and serviced by qualified technical personnel who are familiar with the construction, operation, and potential hazards of this type of machine.

All wiring, disconnects, and fuses should be installed by qualified electrical technicians in accordance with electrical codes in your region.



WARNING: Electrical hazard

Before performing any work on this item, disconnect and lock out electrical power sources to prevent injury from unexpected energization or startup.



WARNING: Refrigerant hazard

Only certified refrigerant technicians should examine and correct problems involving the refrigerant circuit.



CAUTION: Hot Surfaces

Always protect yourself from hot surfaces when working on the Portable Chiller, especially when working on or around the compressor and condenser. These devices can reach up to 160°F (71°C). Allow these devices to cool before performing any maintenance or troubleshooting.

A FEW WORDS OF CAUTION

The Troubleshooting section covers problems directly related to the operation and maintenance of the Portable Chiller. Additional troubleshooting help can be found in the documentation manuals included with this User Guide.

Types of conditions you may see include control problems (not lighting, or lighting and not running), and alarm conditions.

IDENTIFYING THE CAUSE OF A PROBLEM

ANSWERING ALARMS

When an alarm condition occurs, the Alarm light on the control panel lights and the control screen displays the alarm message.

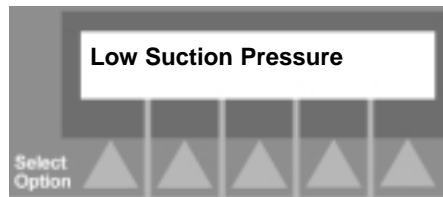

Before an alarm can be reset with the acknowledge key, the alarm condition must be cleared. Refer to the Alarm table and the Troubleshooting tables to troubleshoot the alarm condition(s). After correcting the condition, remove the alarm from the screen. Press and hold the Alarm Silence/Reset button for a minimum of 3 seconds to remove alarm from screen. To begin running the chiller again, press the Run button on the Main screen.

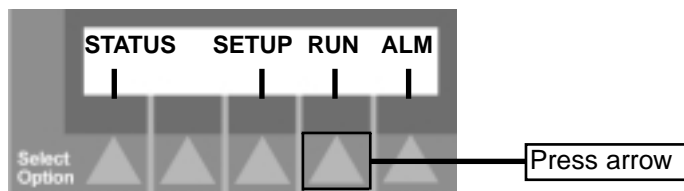

If there is a fault affecting compressor operation such as overload, high or low discharge pressure, compressor fault, etc., there is a three-minute delay before the compressor can be started. The compressor light will flash quickly indicating that manual reset is necessary. The manual reset should be performed only after the alarm condition has been diagnosed and corrected. The manual reset will start the compressor provided all other permissives are enabled. To manually reset the compressor, press the Alarm Silence button and the Enter button simultaneously.

To view a list of the last 10 alarms, refer to Alarm History Screens, in the Troubleshooting section of this manual. Alarms are numbered and listed in order of occurrence, starting with the most recent.

Before an alarm can be reset with the acknowledge key, the alarm condition must be cleared. To acknowledge an alarm is press and hold the Shift button for 3 seconds.

When the temperature falls below the Low To Process Temperature cut out, the compressor shuts off. The Alarm light illuminates and the PLC displays "Low Temperature Cutout". The process or recirculation pump remains running until the Stop button is pressed.

When the To Process Temperature increases to 95°F (35°C) the compressor shuts off. The Alarm light illuminates and the PLC displays "High Temp Safety (Temp>95°F)". The process pump remains running until the Stop button is pressed.

If the temperature rises above the setpoint a high temperature deviation occurs. The degrees Fahrenheit deviation is a variable from 3 to 20, adjustable on a Setup screen. If a high deviation is present the Alarm light illuminates and the PLC displays "High Temperature Deviation". The alarm can be cleared after the temperature drops below the high temperature deviation setpoint or the high deviation is changed to a larger value and the alarm is acknowledged. Acknowledge the alarm by pressing the Stop Chiller button.

If the low water level switch indicates a low water level, the compressor and process pump will shut down. The "alarm" light illuminates and the PLC indicates "Low Water Tank Level". The process pump will remain running until the Stop button is pressed.

If the flow switch (FS-1) detects a low flow condition, the compressor and process pump will be shut down. The "alarm" light illuminates and the PLC indicates "Flow Fault". The process pump will remain running until the Stop button is pressed.

When the refrigerant suction pressure (PT-1) goes below 28 PSIG the compressor will be shut off. The "alarm" light illuminates and the PLC indicates "Low Suction Pressure" for the compressor on a single compressor system and compressor 1 on a dual compressor system. The PLC will indicate "Low Suction Pressure 2" for compressor 2 on a dual compressor system. The process pump will remain running until the Stop button is pressed.

ALARM CONDITIONS

Low Temperature Cutout

High Temp Safety
(Temp >95°F)

High Temperature Deviation

Low Water Tank Level

Flow Fault

Low Suction Pressure

Low Suction Pressure 2

ALARM CONDITIONS

CONT'D



High Discharge Pressure



High Discharge Pressure 2



Compressor Overload



Compressor Overload 2



Pump Overload



High Discharge Temperature



Evaporator Filter Fault

If refrigerant discharge pressure (PT-2) goes above 270 psig (for water-cooled models) or 350 psig (for air-cooled models) the compressor shuts down. The Alarm light illuminates and the PLC indicates "High Discharge Pressure" for the compressor on a single compressor system and compressor 1 on a dual compressor system. The PLC will indicate "High Discharge Pressure 2" for compressor 2 on a dual compressor system. The process pump will remain running until the Stop button is pressed.

If the compressor overloads and trips the MSP, the compressor shuts down. The Alarm light illuminates and PLC indicates "Compressor Overload" for the compressor on a single compressor system and compressor 1 on a dual compressor system. The PLC indicates "Compressor 2 Overload" for compressor 2 on a dual compressor system. The MSP must be reset inside the control panel. The process pump remains running until the Stop button is pressed.

If the process or recirculation pump overloads and trips the MSP, the compressor and pump(s) shut down. The MSP must be reset inside the control panel. The Alarm light illuminates and PLC indicates "Pump Overload" for a process pump overload.

The 3.5 and 5 hp compressors (used on W2-3.5, W2-5, A2-3.5 and A2-5) have a high discharge refrigerant temperature switch (TSHH-1). If the switch detects a high discharge temperature the compressor shuts off immediately. The alarm light illuminates and the PLC indicates "High Discharge Temperature". The process pump remains running until the Stop button is pressed.

Each chiller has a differential pressure switch (PDS-2) on the evaporator. This switch indicates a high-pressure drop through the Evaporator and strainer, usually the result of a dirt strainer or fouled evaporator. When this condition is detected, the alarm light (and strobe) illuminate and the PLC indicates "Evaporator Filter Fault". The compressor and pump(s) continue to run. Press the Enter button to clear the message from the screen. The message continues to display every 60 minutes.

ALARM CONDITIONS

CONT'D

Water-cooled chillers have a differential pressure switch (PDS-1) on the condenser water. This switch indicates a high-pressure drop through the condenser and strainer, usually the result of a dirt strainer or fouled condenser. The alarm light (and strobe) illuminate and the PLC displays the message "Condenser Filter Fault". The compressor and pump(s) continue to run. Press the Enter button to clear the message from the screen. The message continues to display every 60 minutes.



The 7.5 HP and larger compressors have a High Temperature Protector Module to protect the compressor from high internal temperatures, overcurrent conditions and phase imbalance. On single compressor systems (and dual compressor systems with only one compressor enabled), when the normally closed contact opens, it shuts off the compressor immediately and the contact remains open for 30 minutes. The PLC indicates "Comp 1 Rotation Error" on single compressor systems and for compressor 1 on dual compressor systems. A fault on compressor 2 on a dual compressor system displays "Comp 2 Rotation Fault". When the contact closes and the fault is acknowledged, the compressor will restart. On dual compressor units, if the lead compressor's Protector Module contact opens, the lag compressor becomes the lead compressor and the alarm is displayed. When the 30-minute delay has expired and the alarm is acknowledged, the compressor that had faulted remains the lag compressor. If the lag compressor's Protector Module contact opens, the compressor shuts off and the alarm is initiated. This alarm can be cleared after the 30-minute delay and the alarm is acknowledged.

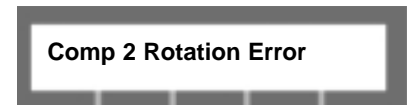
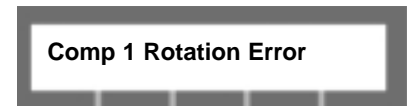

To clear the alarm(s) press and hold the Shift button for three seconds. To start the chiller once the 3-minute compressor down time has expired, press the Run button on the Run Screen.

The alarms are logged in an alarm history table. The last 5 alarms (except the high temp deviation alarm) are recorded and display on the Alarm screen, along with the alarm number, To Process temperature set point, the actual To Process temp, the Refrigerant Discharge Pressure, Refrigerant Suction Pressure, and the time since the last alarm condition. An additional 2 alarm histories are displayed in the Conair Factory screens.

ALARM ERRORS

Alarm Message	Description
Low Water Tank Level	The fluid level in the pump tank is low.
Flow Fault	There is low process fluid flow at the pump discharge.
Low Suction Pressure	The refrigerant pressure, measured at the inlet of compressor 1, is low.
High Discharge Pressure	The refrigerant pressure, measured at the inlet of compressor 1, is high.
Process Pump Overload	High amperage condition; the pump is drawing too much current.
High Temperature Safety Temp >95°F	The To Process fluid temperature is above 95°F, measured at the evaporator outlet.
Low Temperature Cutout	If the To Process fluid temperature falls °5 below the minimum setpoint (measured at the evaporator outlet) the compressor shuts off to allow the temperature to rise.
Compressor Overload	High amperage condition; compressor 1 is drawing too much current.
High Temperature Temperature >75°F for 5 min	To Process fluid temperature is above 75°F (measured at the evaporator outlet) after the compressor has been running for five minutes at startup.
Evaporator Filter Fault	The filter in the process water line is clogged.
Condenser Filter Fault	The filter in the condenser water line is clogged (water-cooled models).
High Discharge Pressure 2	The refrigerant pressure, measured at compressor 2 outlet, is high.
Low Suction Pressure 2	The refrigerant pressure, measured at compressor 2 outlet, is low.
Compressor 2 Overload	High amperage condition; compressor 2 is drawing too much current.
Compressor 2 Rotation Fault	Compressor 2 is wired incorrectly. Two of the lead wires need switched.
Fan Overload	High amperage condition; the fan motor is drawing too much current.
Discharge Pressure Sensor Failure	The sensor is incorrectly reading discharge pressure.
Discharge Pressure 2 Sensor Fault	Sensor 2 is incorrectly reading discharge pressure.
Fan VFD Alarm	The variable frequency drive on the fan failed.
Recirc Pump Overload	High amperage condition; the recirculation pump is drawing too much current.

ALARM HISTORY SCREENS

The alarm history screens display the last 10 alarms that have occurred. They are listed in the order of newest to oldest. Scroll through the alarm history screens by pressing the scroll arrows. The Next arrow takes you back in time. The alarm screen displays the alarm number (1-10) and an alarm description. Pressing the Select Option arrows allows the operator to view the pressures and temperatures at time of the alarm.

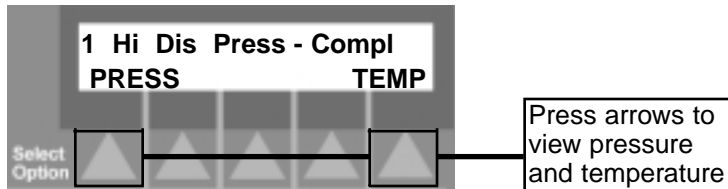

When PRESS is selected discharge pressure information at the time of the alarm displays.

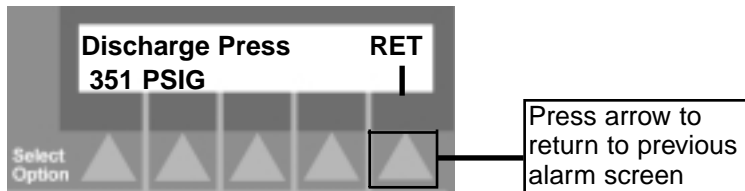

Pressing the Escape key returns to the main menu. Pressing the Next arrow displays the suction pressure at time of the alarm.

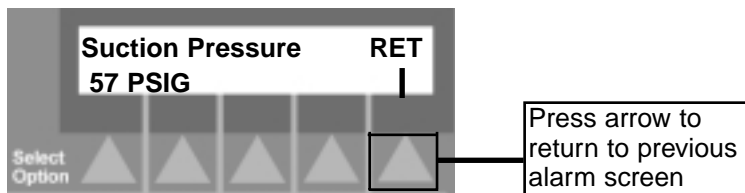

For dual compressor units, the suction and discharge pressures at time of alarm of the second compressor are also captured. These can be viewed by pressing the scroll arrows.

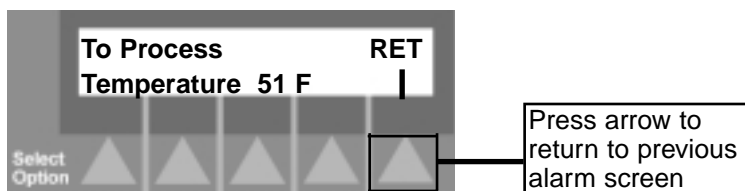

When Temp is selected from the alarm screen, the To Process Temperature at the time of the alarm displays. Pressing the RET select option key returns to the alarm.

Pressing the Next arrow displays the From Process Temperature at the time of the alarm. Scroll through the four temperature values by pressing the Prev and Next arrows.

ALARM SCREEN LEGEND

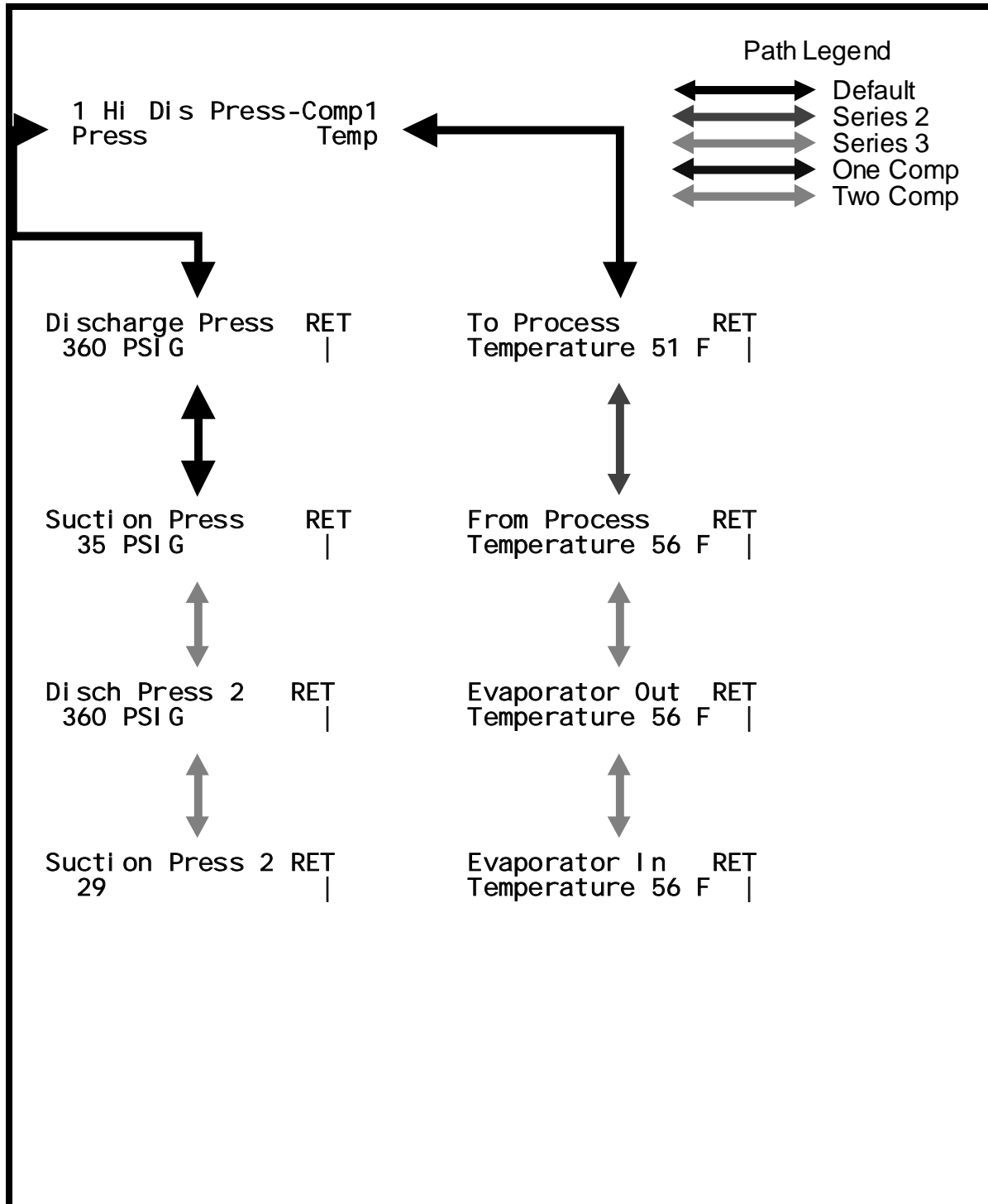

Look here if the control panel is not lit, or if the power is on and the Portable Chiller will not run.

CONTROL PROBLEMS

Symptom	Possible cause	Solution
The control is not lit and the chiller is not working.	Power is not reaching the chiller.	<input type="checkbox"/> Check the power cord and plug. Make sure the cord and plug are properly connected. <input type="checkbox"/> Make sure the main disconnect switch is on. <input type="checkbox"/> Check fuses and breakers. Replace or reset as required. See Replacing Fuses, in the Troubleshooting section.
	The correct power is not reaching the unit	Check the voltage specification on the chiller nameplate.
	There is a problem with the PLC.	<input type="checkbox"/> Check fuses and replace as needed. See Replacing Fuses, in the Troubleshooting section. <input type="checkbox"/> Check the cable between the control panel and the PLC; reconnect or replace as needed. <input type="checkbox"/> Check the PLC indicator lights: Power and Program Run lights should be lit. Contact Conair Service if status is not normal.
	There is a problem with the control panel.	The control panel may have failed. Contact Conair Service.

CONTROL PROBLEMS

CONT'D

Symptom	Possible cause	Solution
The control is lit and there is no alarm condition. The compressor hums, but does not run.	The input voltage is incorrect	Check the main supply voltage. It must be within 10% of the nameplate rating.
	There is a phase loss.	<ul style="list-style-type: none"><input type="checkbox"/> Check the fuses on the main power supply. Replace or reset as required. See Replacing Fuses, in the Troubleshooting section.<input type="checkbox"/> Check the phase-to-phase voltages.<input type="checkbox"/> Check phase continuity through the compressor contactor.<input type="checkbox"/> Check the wiring at the compressor.

ALARM CONDITIONS

Alarm	Possible cause	Solution
Low Water Tank Level alarm	Water level in tank is low.	Fill tank to proper level. See Checking Reservoir Level, in the Maintenance section. Inspect for leaks in the process piping. Repair as necessary. See Making Plumbing Connections, in the Installation section.
	Failed Level switch.	Check level gauge and compare it to status of the level switch by checking continuity of switch in electrical enclosure. Refer to wiring diagrams. Clean switch; replace as needed.
	IF CHILLER HAS AUTO-FILL OPTION:	
	Solenoid valve faulty.	Check level gauge and compare it to status of the level switch by checking continuity of switch in electrical enclosure. Refer to wiring diagrams. Clean switch; replace as needed.
	Water supply valve closed.	Open supply valve.
Input wiring to PLC incorrect.	Check wiring diagrams and compare to wiring to PLC; correct as needed.	

ALARM CONDITIONS

Alarm	Possible cause	Solution
Flow Fault alarm	The To Process and From Process valves are closed.	Open valve(s).
	The Process fluid strainer is clogged.	Clean the strainer.
	Water level in reservoir is low and float switch failed.	Fill the reservoir. See Making Process Plumbing Connections, in the Installation section.
	The evaporator is fouled.	Clean Evaporator. See Cleaning the Evaporator or Water-cooled Condenser, in the Maintenance section.
	Pump is not running.	Check the overload module. Reset or replace as needed. See Replacing Overload Modules, in the Troubleshooting section.
	Pump is running backwards; no pump pressure is indicated on pump discharge pressure gauge.	Switch any two of the three main power leads.
	Evaporator is frozen.	Apply warm air to the evaporator to thaw.

ALARM CONDITIONS CONT'D

Alarm	Possible cause	Solution
Low Suction Pressure alarm	No or low flow with a failed flow switch and RTD.	Check To Process and From Process valves to see if they are open. Check Flow switch and RTD. Replace as needed.
	Compressor suction valve is closed.	Open valve.
	The Evaporator is fouled.	Clean Evaporator. See Cleaning the Evaporator or Water-cooled Condenser, in the Maintenance section.
	Evaporator frozen.	<ul style="list-style-type: none"> <input type="checkbox"/> Check flow switch, RTD, temperature transmitter and low temperature cutout on temperature controller. Replace as needed. <input type="checkbox"/> Check PLC control for proper percent ethylene glycol or propylene glycol solution. Change percent glycol setpoint, if needed. Add glycol if needed.
	Faulty TXV solenoid.	Check wiring, voltage, coil and relay (see electrical drawings); replace as needed.
	Refrigerant leak.	Check for oil in chiller cabinet and bubbles in refrigerant sight glass. Consult Conair Service for repair.
	Faulty pressure transducer.	See Checking the Pressure Transducer, in the Troubleshooting section.
	Condenser air or water too cold.	Check air/water temperature. Water should be 65 F or higher; air temperature should be 60 F or higher.
	Wiring incorrect.	Use wiring diagrams and check wiring. Correct as needed.

ALARM CONDITIONS

Alarm	Possible cause	Solution
High Discharge Pressure alarm	Clogged/dirty air-cooled condenser.	Clean the coil. See <i>Cleaning the Air-cooled Condenser</i> , in the Maintenance section.
	Blocked air flow to air-cooled condenser.	Move chiller or unblock air passageway.
	Low condenser water flow or water too warm to water-cooled condenser.	Check required flow; see Specifications in the Description section.
	Blocked condenser water line or valve closed.	Unblock line; open valve. Check and clean filter strainer.
	Condenser fouled.	Clean the condenser. See <i>Cleaning the Air-cooled Condenser</i> , and <i>Cleaning the Evaporator or Water-cooled Condenser</i> , in the Maintenance section.
	Fan motor not running.	Check fan cycling operation settings. Motor may be bad. See Drive manual electrical information accompanying this user guide.
	Faulty liquid line solenoid valve.	Check voltage. Replace valve as needed.
	Compressor discharge valve closed (if supplied).	Open valve.
	Overcharged with refrigerant.	See <i>Checking the Refrigerant Charge</i> , in the Maintenance section.
	Faulty water regulating valve.	Repair or replace the valve.
Faulty pressure transducer.	See <i>Checking the Pressure Transducer</i> , in the Troubleshooting section.	
Input wiring to PLC incorrect.	Check wiring diagrams and compare to wiring to PLC; correct as needed.	

ALARM CONDITIONS CONT'D

Alarm	Possible cause	Solution
Comp 1 Rotation Error alarm	Compressor 1 is wired incorrectly.	Shut off chiller supply voltage. Switch any two leads: <ul style="list-style-type: none">● at compressor if it was replaced.● at main terminal block if new unit installation. Turn chiller on.
	High pressure transducer is faulty.	See Checking the Pressure Transducer, in the Troubleshooting section.

ALARM CONDITIONS

Alarm	Possible cause	Solution
Pump Overload alarm	Overload set incorrectly.	Check table on wiring diagram for correct full load amperage (FLA) draw. Adjust overload accordingly.
	Low supply voltage.	<ul style="list-style-type: none"> <input type="checkbox"/> Check supply voltage. Supply voltage to contactor should be +/- 10% of name-plate voltage. <input type="checkbox"/> Check wire terminations and connections. Tighten if loose.
	Faulty contactor	Check line and load side of contactor. It should be less than 5 volt drop across the contactor. If it is not, replace the contactor. See Replacing the Contactor in the Troubleshooting section.
	Faulty overload module.	Check amp draw of circuit. If it is under the rated setting, replace the overload module. See Replacing Overload Modules, in the Troubleshooting section.
	Control voltage is incorrect.	Check 24VDC required for contactor auxiliary input. If control voltage is OK replace PLC.

ALARM CONDITIONS CONT'D

Alarm	Possible cause	Solution
High Temperature Safety Temp >95 F alarm	The hot gas bypass valve is not working properly (possibly stuck open)	Shut isolation valve to the Hot Gas Bypass solenoid. If the To Process temperature starts to go down, the solenoid valve is faulty. Have a certified refrigeration technician replace the solenoid valve.
	Load is too high for the chiller.	Remove some load from the process.
	Fluid is not flowing between the supply outlet and return outlet.	Check for plugged pipes, closed valves, or failed flow switch.
	The compressor is not running.	Check to see if Compressor light is lit on the control. If it is not, check compressor overload in compressor terminal box. Check power to compressor and power to compressor contactor.
	Failed RTD or Temperature Transmitter.	See Checking the Temperature Transmitter and RTD in the Troubleshooting section.

ALARM CONDITIONS

Alarm	Possible cause	Solution
Low Temperature Cutout alarm	The hot gas bypass valve is not working properly (possibly stuck closed).	If the To Process temperature starts to go down, the solenoid valve is faulty. Have a certified refrigeration technician replace the solenoid valve. Check voltage to coil; replace coil if needed.
	Fluid flow is insufficient.	Check for plugged pipes, closed valves, or failed flow switch.
	Failed RTD or Temperature Transmitter.	See Checking the Temperature Transmitter and RTD, in the Troubleshooting section.
	Hot Gas Bypass valve relay failed.	Replace as needed (see electrical drawings.)

ALARM CONDITIONS CONT'D

Alarm	Possible cause	SOLUTION
Compressor Overload alarm	Overload set incorrectly.	Check table on wiring diagram for correct rated load amperage (RLA) draw. Adjust overload accordingly.
	Low supply voltage.	<input type="checkbox"/> Check supply voltage. Supply voltage to contactor should be +/- 10% of nameplate voltage. <input type="checkbox"/> Check wire terminations and connections. Tighten if loose.
	Faulty contactor	Check line and load side of contactor. It should be less than 5 volt drop across the contactor. If it is not, replace the contactor. See Replacing the Contactor in the Troubleshooting section.
	Faulty overload module.	Check amp draw of circuit. If it is under the rated setting, replace the overload module. See Replacing Overload Modules, in the Troubleshooting section.

ALARM CONDITIONS

Alarm	Possible cause	Solution
High Temperature Temp > 75 F for 5 min alarm	Load too high for chiller.	Reduce load on chiller; if not able to reduce load, choose a chiller with more capacity.
	Refrigeration circuit not working properly.	Check refrigerant circuit. See Checking Refrigerant Charge, in the Installation section.
High Discharge Temperature alarm (models 3.5 and 5 HP models only)	Compressor malfunctioned.	Check voltage to compressor. Check contact points on contactor. Replace if needed.
	Refrigeration charge low.	Check temperature on suction line; it should be less than 60 °F. Check refrigerant sight glass for bubbles. Charge with refrigerant if needed.
	Temperature sensor is faulty (for A/W2-3.5 and A/W2-5 models only).	Replace temperature sensor mounted on the discharge side of the compressor (trip point is 260 °F).

ALARM CONDITIONS CONT'D

Alarm	Possible cause	Solution
Evaporator Filter Fault alarm	Clogged strainer.	Clean strainer; replace as needed.
	Evaporator fouled.	Clean Evaporator. See Cleaning the Evaporator or Water-cooled Condenser, in the Maintenance section.
	A valve is closed in the process water flow piping.	Check valves; open if closed.
	There is a PLC voltage problem.	Check voltage (see electrical drawings).
	The differential pressure switch is faulty.	Check wiring and voltage; replace switch as needed.
	Other piping obstruction.	Check that all piping is large enough to carry fluid. Replace any piping or conduit that is too small. Clean any clogs.

ALARM CONDITIONS

Alarm	Possible cause	Solution
Condenser Filter Fault alarm (Water-cooled models only)	Clogged strainer.	Clean strainer; replace as needed.
	The differential pressure switch is faulty.	Check wiring and voltage; replace switch as needed.
	Other piping obstruction.	Check that all piping is large enough to carry fluid. Replace any piping or conduit that is too small. Clean any clogs.
	Condenser fouled.	Clean Condenser. See Cleaning the Evaporator or Water-cooled Condenser, in the Maintenance section.

ALARM CONDITIONS CONT'D

Alarm	Possible cause	Solution
High Discharge Pressure 2 alarm	Clogged/dirty air-cooled condenser.	Clean the coil. See <i>Cleaning the Air-cooled Condenser</i> , in the Maintenance section.
	Blocked air flow to air-cooled condenser.	Move chiller or unblock air passageway.
	Low condenser water flow or water too warm to water-cooled condenser.	Check required flow; see Specifications in the Description section.
	Blocked condenser water line or valve closed.	Unblock line; open valve. Check and clean filter strainer.
	Condenser fouled.	Clean the condenser. See <i>Cleaning the Air-cooled Condenser</i> , and <i>Cleaning the Evaporator or Water-cooled Condenser</i> , in the Maintenance section.
	Fan motor not running.	Check fan cycling operation settings. Motor may be bad. See Drive manual electrical information accompanying this user guide.
	Faulty liquid line solenoid valve.	Check voltage. Replace valve as needed.
	Compressor discharge valve closed (if supplied).	Open valve.
	Overcharged with refrigerant.	See <i>Checking the Refrigerant Charge</i> , in the Maintenance section.
	Faulty water regulating valve.	Repair or replace the valve.
Faulty pressure transducer.	See <i>Adjusting the Pressure Transducer</i> , in the Troubleshooting section.	

ALARM CONDITIONS

Alarm	Possible cause	Solution
Low Suction Pressure 2 alarm	No or low flow with a failed flow switch and RTD.	Check To Process and From Process valves to see if they are open. Check Flow switch and RTD. Replace as needed.
	Compressor suction valve is closed.	Open valve.
	The Evaporator is fouled.	Clean Evaporator. See Cleaning the Evaporator or Water-cooled Condenser, in the Maintenance section.
	Evaporator frozen.	<ul style="list-style-type: none"> <input type="checkbox"/> Check flow switch, RTD, temperature transmitter and low temperature cutout on temperature controller. Replace as needed. <input type="checkbox"/> Check PLC control for proper percent ethylene glycol or propylene glycol solution. Change percent glycol setpoint, if needed. Add glycol if needed.
	Faulty TXV solenoid.	Check wiring, voltage, coil and relay (see electrical drawings); replace as needed.
	Refrigerant leak.	Check for oil in chiller cabinet and bubbles in refrigerant sight glass. Consult Conair Service for repair.
	Faulty pressure transducer.	See Checking the Pressure Transducer, in the Troubleshooting section.
	Condenser air or water too cold.	Check air/water temperature. Water should be 65 F or higher; air temperature should be 60 F or higher.
	Wiring incorrect.	Use wiring diagrams and check wiring. Correct as needed.

ALARM CONDITIONS

Alarm	Possible cause	SOLUTION
Compressor 2 Overload alarm	Overload set incorrectly.	Check table on wiring diagram for correct rated load amperage (RLA) draw. Adjust overload accordingly.
	Low supply voltage.	<input type="checkbox"/> Check supply voltage. Supply voltage to contactor should be +/- 10% of nameplate voltage. <input type="checkbox"/> Check wire terminations and connections. Tighten if loose.
	Faulty contactor	Check line and load side of contactor. It should be less than 5 volt drop across the contactor. If it is not, replace the contactor. See Replacing the Contactor in the Troubleshooting section.
	Faulty overload module.	Check amp draw of circuit. If it is under the rated setting, replace the overload module. See Replacing Overload Modules, in the Troubleshooting section.
	Control voltage is incorrect.	Check 24VDC required for contactor auxiliary input. If control voltage is OK replace PLC.

ALARM CONDITIONS CONT'D

Alarm	Possible cause	Solution
Compressor 2 Rotation Fault alarm	Compressor 2 is wired incorrectly.	Shut off chiller supply voltage. Switch any two leads: <ul style="list-style-type: none">● at main terminal block if new unit installation.● at compressor if it was replaced. Turn chiller on.
	High pressure transducer is faulty.	Check discharge pressure on the Status screen. See Checking the Pressure Transducer, in the Troubleshooting section.

ALARM CONDITIONS

Alarm	Possible cause	Solution
Fan Overload alarm	Access door is open.	Close access door.
	Overload switch has been manually shut off.	Reset overload switch.
	Overload set incorrectly.	Check table on wiring diagram for correct full load amperage (FLA) draw. Adjust overload accordingly.
	Low supply voltage.	<ul style="list-style-type: none"> <input type="checkbox"/> Check supply voltage. Supply voltage to contactor should be +/- 10% of nameplate voltage. <input type="checkbox"/> Check wire terminations and connections. Tighten if loose.
	Faulty contactor	Check line and load side of contactor. It should be less than 5 volt drop across the contactor. If it is not, replace the contactor. See Replacing the Contactor in the Troubleshooting section.
	Faulty overload module.	Check amp draw of circuit. If it is under the rated setting, replace the overload module. See Replacing Overload Modules, in the Troubleshooting section.
	Control voltage is incorrect.	Check 24VDC required for contactor auxiliary input. If control voltage is OK replace PLC.

ALARM CONDITIONS CONT'D

Alarm	Possible cause	SOLUTION
Discharge Pressure Sensor Failure alarm	Wiring bad.	Check wiring; correct as needed.
	There is RF interference.	Check for any electromagnetic interference (for example, from radios). Remove any objects causing the problem.
	The sensor has been damaged.	Check discharge pressure status. See Checking the Pressure Transducer, in the Maintenance section. Repair or replace the sensor.
Discharge Pressure Sensor 2 Failure alarm	Wiring bad.	Check wiring; correct as needed.
	There is RF interference.	Check for any electromagnetic interference (for example, from radios). Remove any objects causing the problem.
	The sensor has been damaged.	Check discharge pressure status. See Checking the Pressure Transducer, in the Maintenance section. Repair or replace the sensor.

CHECKING AND REPLACING SWITCHES

Always refer to the wiring diagrams that came with your chiller to locate specific electrical components.



WARNING: Electrical hazard

Before performing any work on this unit, disconnect and lock out electrical power sources to prevent injury from unexpected energization or startup.

The pump tank has one or two float switches. The float switch (low level cutout) activates the Low Water Level alarm. There is also a flow switch in the process fluid line to verify flow.

To replace a level or flow switch:

- 1 Disconnect and lockout power to the chiller.**
- 2 Open the electrical enclosure and locate the connection for the correct switch on the terminal switch.** Refer to the wiring diagrams you received with your chiller to find the correct terminals.
- 3 Check the switch.** Check continuity within the switch and make sure it corresponds to the condition of the switch. Clean the switch if needed.
- 4 Replace the switches as needed.** Drain the tank to replace the switch(es).

To check a flow switch:

- 1 Remove the electrical cover on the flow switch.**
- 2 Slide the top of the switch housing over until the N.O. (normally open) shows when electrical cover is placed back on.**
- 3 Replace electrical cover on flow switch.**

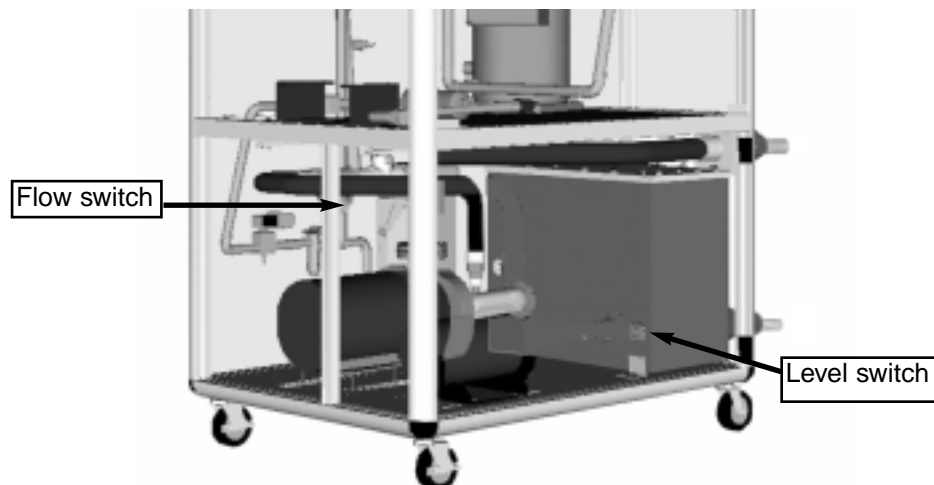



WARNING: Coolant hazard

Refrigerant can cause freezing of skin. All proper precautions should be taken any time the refrigerant system is worked on. Any adjustment that involves the refrigerant should only be performed by a certified refrigeration technician.

CHECKING THE PRESSURE TRANSDUCER

The transducer produces a 0.5-4.5 VDC analog signal that is read by the PLC, which relates it to a pressure, based on the range of the transducer. To check and adjust the pressure transducer:

- 1 Locate the pressure transducer.**
Use the piping diagrams that came with your chiller for exact location. Location varies depending on size of your chiller.
- 2 Check the connections.**
Make sure all connections to the transducer are secure. Tighten as needed.
- 3 Check the supply voltage to the transducer.**
Voltage should be 5VDC. Refer to the wiring diagram for the exact location.
- 4 Check the control signal in the electrical panel**
if the supply voltage is correct (step 3). Refer to the wiring diagram for the exact location. If the signal is outside the 0.5-4.5 VDC range replace the transducer.
- 5 Check the transducer with a gauge.**
If the reading is within the 0.5-4.5 VDC range, test the line with a refrigeration gauge. Compare this number with the reading on the Control screen. To get to the proper screen on the control, from the main screen, press Status. Use the scrolling arrows to move to the Suction Pressure or Discharge Pressure screen. If the gauge and PLC screen readings are not within 5% of each other, replace the transducer.

Always refer to the wiring diagrams you received with your chiller to locate specific electrical components.

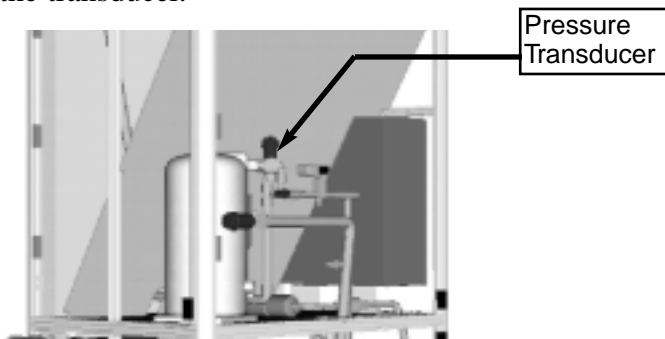

REPLACING THE RTD

To replace the RTD:

- 1 Disconnect and lockout power to the chiller.**
- 2 Disconnect the To Process tubing from the To Process connection.**

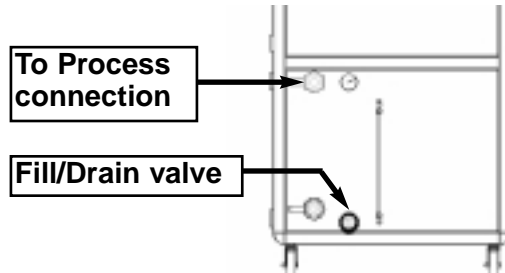

Always refer to the wiring diagrams you received with your chiller to locate specific electrical components.

- 3 Open the Drain/Fill valve and drain water** from the unit so the water level is lower than the RTD.
- 4 Open the side of the chiller.**
- 5 Disconnect the RTD wiring from the transmitter electrical box.** Refer to the wiring diagram.
- 6 Remove the RTD.**
Loosen the compression nut to slide the RTD out of the evaporator.
- 7 Install the new RTD.**
The new RTD should be inserted in the evaporator so that the tip is extended completely through the evaporator.
- 8 Wire the RTD to the temperature transmitter and to the electrical box.**

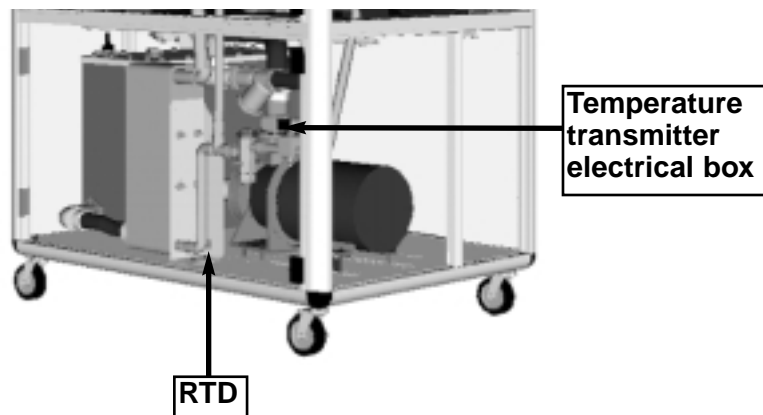

The Conair Portable Chiller uses a standard 100 ohm RTD to monitor process temperature. A transmitter is also included and is located in the temperature transmitter electrical box.

CHECKING THE TEMPERATURE TRANSMITTER AND RTD

To check the temperature transmitter and RTD:

- 1 Disconnect and lockout power to the chiller.**
- 2 Open the electrical enclosure.**
Check wire connections at the terminals. Refer to the wiring diagram.
- 3 Find the temperature sensor in the evaporator.**
- 4 Check the wiring and connections**
from the sensor to the temperature transmitter electrical box.
- 5 Turn the power on to the chiller control.**
- 6 Check the voltage, resistance and amperage.**

Always refer to the wiring diagrams that came with your chiller to locate specific electrical components.

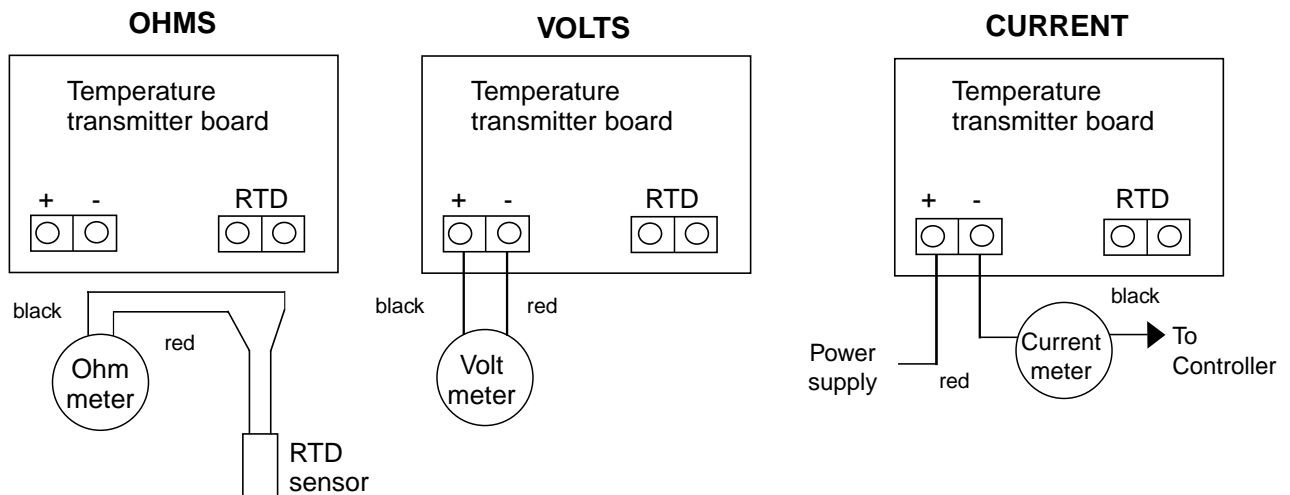
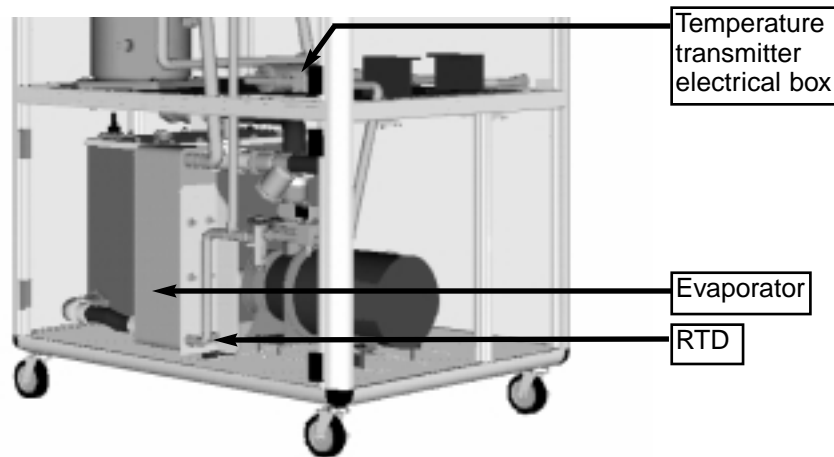

CHECKING THE TEMPERATURE TRANSMITTER AND RTD

CONT'D

Problem	Possible cause	Solution
No reading	No power to board.	Check voltage at power supply. Measure volts across the + and - of the power wires. Voltage should be 8 - 35 VDC.
Reading too low	RTD wires shorted.	Disconnect RTD before testing sensor resistance. Check RTD with ohmmeter. Should be close to 100 ohms.
	Improper range of transmitter (too low).	Disconnect black lead (-) and place current meter in series. Check RTD with current meter. Current should be 4 -20 mA.
	Condensation on board.	Inspect for condensation. Dry with hot air.
Reading too high	RTD opened.	RTD opened. Disconnect RTD before testing sensor resistance. Check RTD with ohmmeter. Should be close to 100 ohms.
	Improper range of transmitter (too high).	Disconnect black lead (-) and place current meter in series. Check RTD with current meter. Current should be 4 -20 mA.
	Condensation on board.	Inspect for condensation. Dry with hot air.
RF Interference	Input power not clean.	Use twisted wires or shielded cable. RF resistant power supply. Use a shielded cable to connect the sensor. Connect the shield to ground. Encase the board in a RF shielded enclosure.

REPLACING THE TEMPERATURE TRANSMITTER

To replace the temperature transmitter:

- 1 Disconnect and lockout power to the chiller.**
- 2 Open the side of the chiller.**
- 3 Disconnect the RTD wiring from the transmitter electrical box.** Refer to the wiring diagram.
- 4 Disconnect transmitter wiring from main electrical panel.**
- 5 Remove the temperature transmitter electrical box and wiring.**
- 6 Install the new temperature transmitter.**
- 7 Thread the leads of the temperature transmitter through the cabinet leading to the temperature transmitter electrical box.** Wire the temperature transmitter (see wiring diagram).

Always refer to the wiring diagrams you received with your chiller to locate specific electrical components.

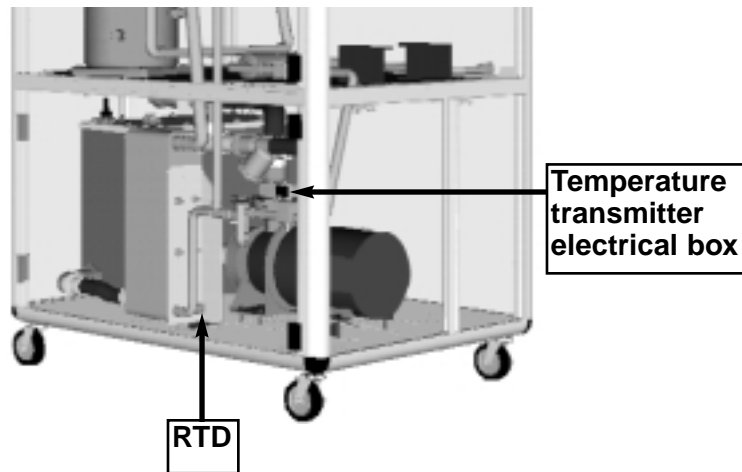

REMOVING PUMP COMPONENTS

The pump's wet end (impeller, motor, and seal assembly) can be removed for service.

- 1 Disconnect and lockout power to the chiller.**
- 2 Open the drain/fill valve and drain the water from the chiller.**

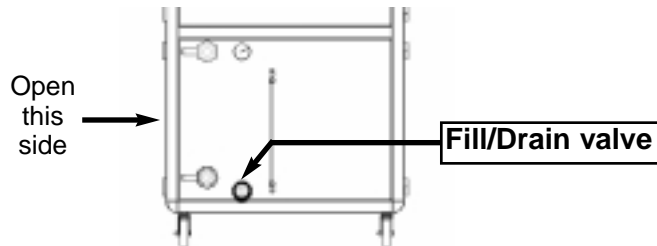

- 3 Open the side of the chiller.**
- 4 Remove the bolts connecting the pump assembly to the pump housing.**
- 5 Remove the pump assembly.**
Carefully slide it sideways away from the pump tank to avoid damage.
- 6 Inspect, clean, and replace pump parts**
as needed. Separate the pump assembly from the pump volute (casing) by prying the flanges and pulling apart. Follow the disassembly and reassembly procedures in the pump manufacturer's manual that accompanies this User Guide.



WARNING: Electrical hazard

Before performing any work on this unit, disconnect and lock out electrical power sources to prevent injury from unexpected energization or startup.

REPLACING OVERLOAD MODULES

Normally if the overload trips, resetting the overload and correcting the cause is typically all that is needed. However, if the overload continues to trip, it may be necessary to replace the overload module.

To replace the overload module:

- 1 Disconnect and lockout power to the chiller.**
- 2 Open the electrical enclosure.**
- 3 Locate the overload module and disconnect** the power leads from the module to the device. Refer to the wiring diagram for the exact location. Note the placement of each lead and label as needed.
- 4 Disconnect auxiliary wiring to the module.**
- 5 Loosen the screws and remove the module.**
- 6 Install the new module** and tighten in place with the screws.
- 7 Reconnect wires and leads.**
- 8 Adjust setting to correct Full Load Amps** rating of compressor, fan or pump.
- 9 Restore power to the chiller.**

Always refer to the wiring diagrams you received with your chiller to locate specific electrical components.

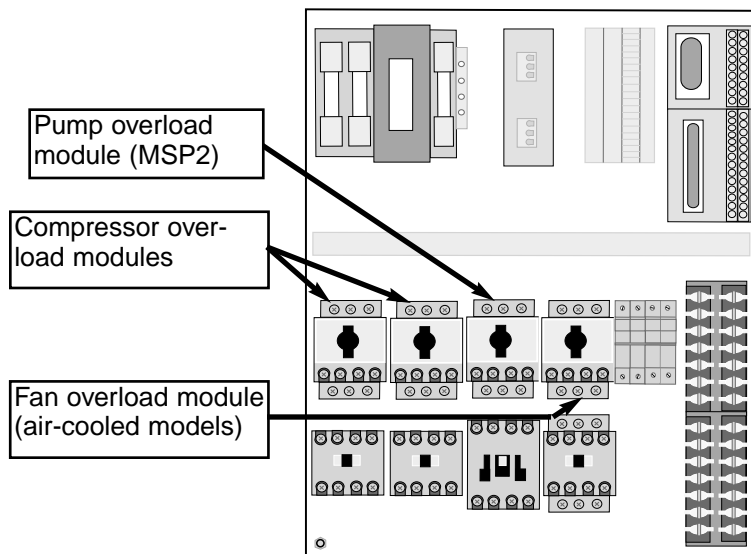

REPLACING THE CONTACTOR



WARNING: Electrical hazard

Before performing any work on this unit, disconnect and lock out electrical power sources to prevent injury from unexpected energization or startup.

Always refer to the wiring diagrams that came with your chiller to locate specific electrical components.

To replace contactor for the pump or compressor:

- 1 Disconnect and lockout power to the chiller.**
- 2 Open the electrical enclosure and locate** the correct contactor. Refer to the wiring diagrams you received with your chiller.
- 3 Disconnect the wiring from the contactor.** Make sure you label each wire so you can correctly install the new unit.
- 4 Remove the contactor by snapping off** the DIN rail mounting.
- 5 Snap in the new contactor on the DIN rail.**
- 6 Reconnect the wiring and reconnect power** to the chiller.

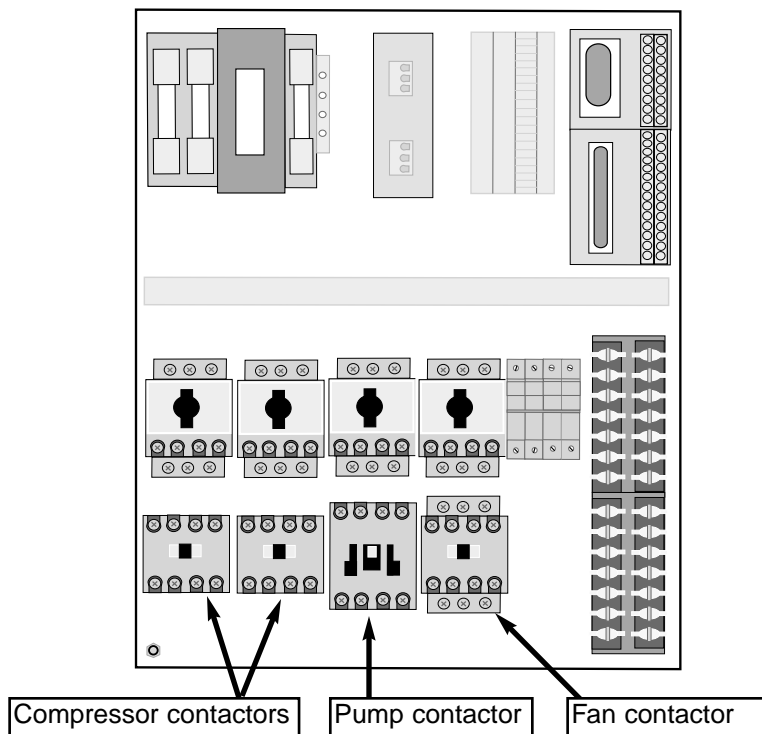



WARNING: Electrical hazard

Before performing any work on this unit, disconnect and lock out electrical power sources to prevent injury from unexpected energization or startup.

REPLACING THE PLC

NOTE: Contact your Conair Service representative before replacing the PLC.

- 1 Disconnect and lockout power to the chiller.**
- 2 Open the electrical enclosure.**
- 3 Unplug connectors from the back of the PLC**
by pulling them straight off.
- 4 Loosen the screws holding the PLC**
- 5 Remove the PLC and shield from the**
enclosure as a single unit.
- 6 Place new PLC into position.**
- 7 Tighten the screws to hold the PLC in place.**
- 8 Replace connectors.**

Always refer to the wiring diagrams you received with your chiller to locate specific electrical components.

The PLC is preprogrammed at the factory. You can tell if the PLC is programmed if it displays the chiller model on the display screen when it powers up. If this does not happen, contact your Conair Service representative.



Conair has made the largest investment in customer support in the plastics industry. Our service experts are available to help with any problem you might have installing and operating your equipment. Your Conair sales representative also can help analyze the nature of your problem, assuring that it did not result from misapplication or improper use.

WE'RE HERE TO HELP

To contact Customer Service personnel, call:



HOW TO CONTACT CUSTOMER SERVICE

From outside the United States, call: 814-437-6861

You can commission Conair service personnel to provide on-site service by contacting the Customer Service Department. Standard rates include an on-site hourly rate, with a one-day minimum plus expenses.

If you do have a problem, please complete the following checklist before calling Conair:

- Make sure you have all model, serial and parts list numbers for your particular equipment. Service personnel will need this information to assist you.
- Make sure power is supplied to the equipment.
- Make sure that all connectors and wires within and between control systems and related components have been installed correctly.
- Check the troubleshooting guide of this manual for a solution.
- Thoroughly examine the instruction manual(s) for associated equipment, especially controls. Each manual may have its own troubleshooting guide to help you.
- Check that the equipment has been operated as described in this manual.
- Check accompanying schematic drawings for information on special considerations.

BEFORE YOU CALL ...

Additional manuals and prints for your Conair equipment may be ordered through the Customer Service or Parts Departments for a nominal fee.

EQUIPMENT GUARANTEE

Conair guarantees the machinery and equipment on this order, for a period as defined in the quotation from date of shipment, against defects in material and workmanship under the normal use and service for which it was recommended (except for parts that are typically replaced after normal usage, such as filters, liner plates, etc.). Conair's guarantee is limited to replacing, at our option, the part or parts determined by us to be defective after examination. The customer assumes the cost of transportation of the part or parts to and from the factory.

PERFORMANCE WARRANTY

Conair warrants that this equipment will perform at or above the ratings stated in specific quotations covering the equipment or as detailed in engineering specifications, provided the equipment is applied, installed, operated and maintained in the recommended manner as outlined in our quotation or specifications.

Should performance not meet warranted levels, Conair at its discretion will exercise one of the following options:

- Inspect the equipment and perform alterations or adjustments to satisfy performance claims. (Charges for such inspections and corrections will be waived unless failure to meet warranty is due to misapplication, improper installation, poor maintenance practices or improper operation.)
- Replace the original equipment with other Conair equipment that will meet original performance claims at no extra cost to the customer.
- Refund the invoiced cost to the customer. Credit is subject to prior notice by the customer at which time a Return Goods Authorization Number (RGA) will be issued by Conair's Service Department. Returned equipment must be well crated and in proper operating condition, including all parts. Returns must be prepaid.

Purchaser must notify Conair in writing of any claim and provide a customer receipt and other evidence that a claim is being made.

WARRANTY LIMITATIONS

Except for the Equipment Guarantee and Performance Warranty stated above, Conair disclaims all other warranties with respect to the equipment, express or implied, arising by operation of law, course of dealing, usage of trade or otherwise, including but not limited to the implied warranties of merchantability and fitness for a particular purpose.

MAINTENANCE LOG

Date	Reading							
Maintenance Item								
Compressor 1, 2 Amps, 100% loaded								
Discharge Pressure 1, 2								
Suction pressure 1, 2								
Evaporator water out temperature								
Process Water Pressure								
Condenser Water Temperature, In/Out								
Condenser Water Pressure, In/Out								
Condenser Fan Amps								
Pump Amps								
Unit Volts Primary Secondary								
Condenser Air Temp In								
Condenser Air Temp Out								
Oil Level								
Super Heat								
Temperature Setpoint								

**Evaporator and Piping
Pressure Drops**

**PRESSURE
TABLES**

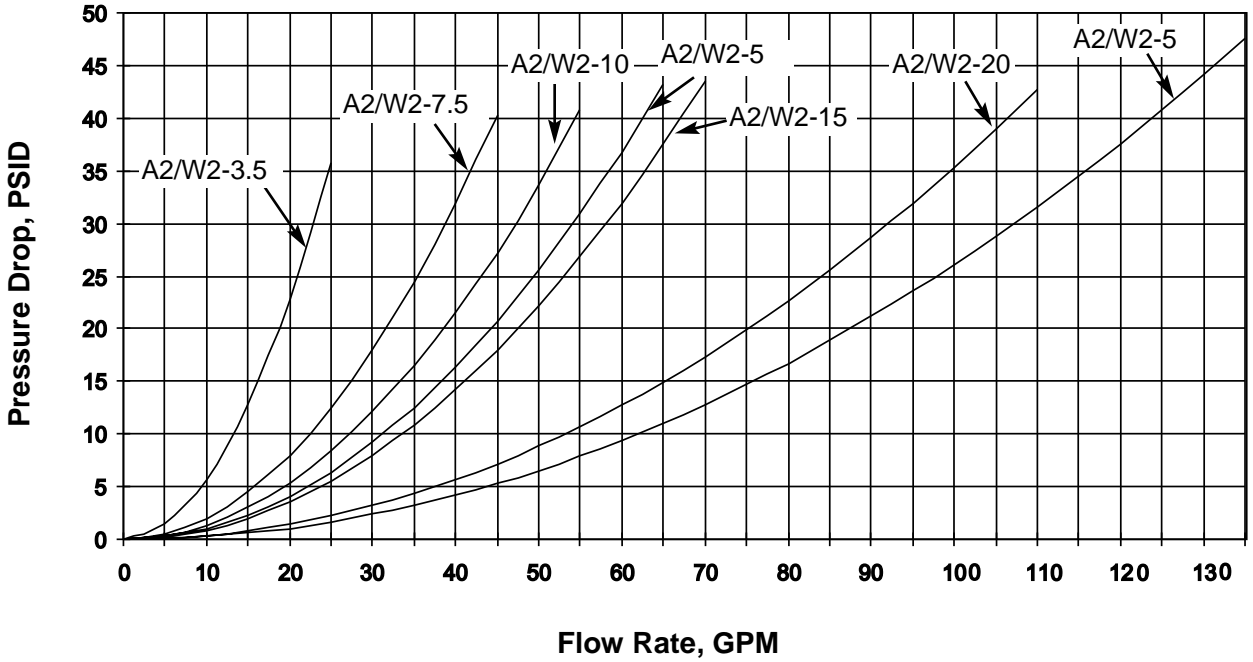

Overhead piping installations above process connections require installing a check valve in the To Process line and a 12 inch (305 mm) riser with check valve and vacuum break in the From Process line to prevent siphoning when shutting down. Install a vent tube to 12 inches (305 mm) above the highest system point to prevent over pressurization. Maximum height of piping above process connections is 10 ft (3 m).

OVERHEAD PLUMBING DETAILS

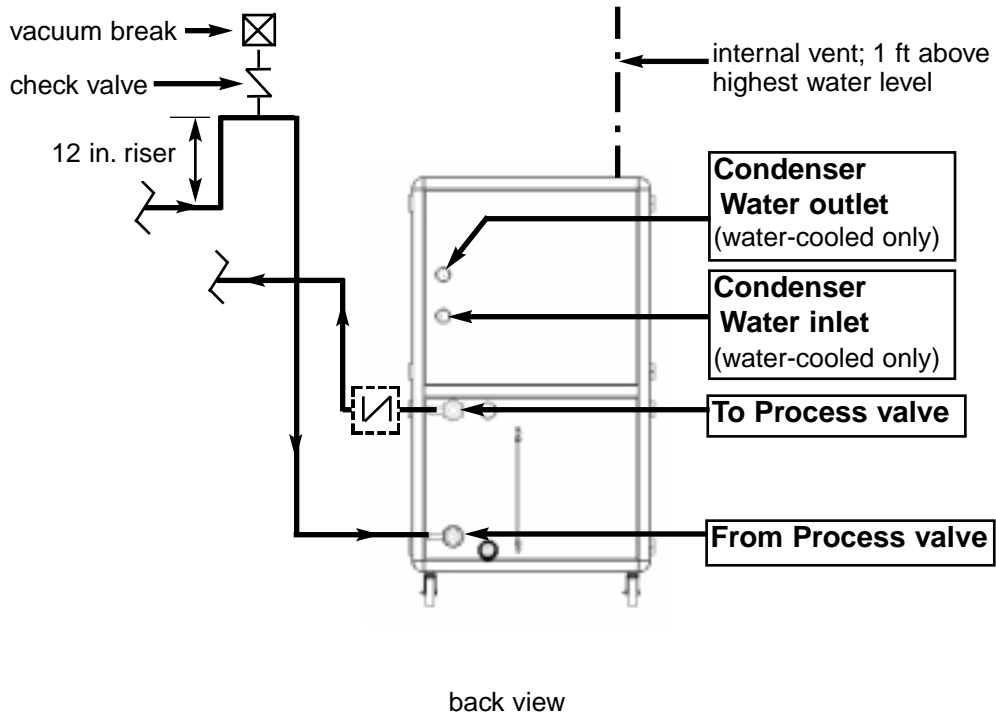

PARTS & DIAGRAMS

- *Spare Parts ListP/D-2*

RECOMMENDED SPARE PARTS

Part Number	Description
	C7-621 PLC/ Operator Panel-Custom black 24VDC, 3A power supply 120VAC 4" Alarm Bell 20VAC White Strobe 24VDC Single Pole Relay, (DIN) w end plate
	22 mm Red extended pushbutton operator 28VDC Green indicator light 28VDC Red indicator light 22 gauge, 15 Conductor cable, w/ Sub D 15 pin female connection
	22 gauge, 37 Conductor cable, w/ Sub D 15 pin female connection MSP-to-Contactor connecting module, 3RA2921-1A MSP-to-Contactor connecting module, 3RA2921-1B MSP-to-Contactor connecting module, 3RA2921-1D
	MSP-to-Contactor connecting module, 3RA2931-1A MSP-to-Contactor connecting module, 3RA2931-1B MSP-to-Contactor connecting module, 3RA2941-1A MSP-to-Contactor connecting module, 3RA2941-1B 3 Pole Contactor w/ 24VDC coil, 7A (AC-3)
	3 Pole Contactor w/ 24VDC coil, 9A (AC-3) 3 Pole Contactor w/ 24VDC coil, 12A (AC-3) 3 Pole Contactor w/ 24VDC coil, 17A (AC-3) 3 Pole Contactor w/ 24VDC coil, 25A (AC-3) 3 Pole Contactor w/ 24VDC coil, 28A (AC-3)
	3 Pole Contactor w/ 24VDC coil, 32A (AC-3) 3 Pole Contactor w/ 24VDC coil, 40A (AC-3) 3 Pole Contactor w/ 24VDC coil, 50A (AC-3) 3 Pole Contactor w/ 24VDC coil, 65A (AC-3) Motor Starter Protector (1.8-2.5A)
	Motor Starter Protector (2.2-3.2A) Motor Starter Protector (3.5-5.0A) Motor Starter Protector (4.5-6.3A) Motor Starter Protector (5.5-8.0A) Motor Starter Protector (7.0-10.0A)

RECOMMENDED SPARE PARTS

Part Number	Description
	Motor Starter Protector (28.0-40.0A) Motor Starter Protector (40.0-50.0A) Motor Starter Protector (45.0-63.0A) Motor Starter Protector (57.0-75.0A) Motor Starter Protector (20.0-25.0A)
	Motor Starter Protector (18.0-25.0A) Motor Starter Protector (22.0-32.0A) Motor Starter Protector (9.0-12.5A) Motor Starter Protector (11.0-16.0A) Motor Starter Protector (14.0-20.0A)
	Motor Starter Protector (17.0-22.0A) MSP Auxiliary Contact Block (2n.o.) MSP Line Side Feeder MSP Feeder Lug (3RV101, 3RV102) MSP Feeder Lug (3RV103)
	Normally Open contact block Normally Closed contact block 3 Pole SIMICONT Contactor w 24VDC Coil (9A) Control Terminal Block, Size 4 Terminal Block End Bracket
	Terminal Block Barrier Littlefuse 0.5A Fuse, 250VAC Littlefuse 3.0A Fuse, 250VAC Littlefuse 5.0A Fuse, 250VAC Littlefuse 0.25A Fuse, 600VAC
	Littlefuse 2.0A Fuse, 600VAC 1 Pole Fuseblock Cover Lit Transformer Touch Safe Cover Lit 1 Pole Secondary Fuseblock 2 Pole Primary Fuseblock
	Littlefuse 2 Pole Ultrasafe Fuseblock Motorola 5 VDC Voltage Regulator 250VA Control Transformer 230x460, 110/115/120 250VA Control Transformer 550/575/600, 110/115/120 250VA Control Transformer 380/400/415, 110x120

RECOMMENDED SPARE PARTS

Part Number	Description
	250VA Control Transformer 208/230/460, 24/115
	Pump Seal Kit, pump type 231
	Pump Seal Kit, Pump type 233, 3HP
	Pump Seal Kit, Pump type 233, 5HP
	Pump Seal Kit, Pump type 234, 7.5HP
20973003	Pump Seal Kit, Pump type 233, 7.5HP and 10HP
26636101	Pump Seal Kit, Pump type 234, 10HP and 15HP
26629901	Flowtect, Flow Switch, Evap Circuit
	Gems, Float Switch, Process Tank
	Pressure Gauge, Dual Scale, 0-160PSIG
26636001	Suction Pressure Transducer, 0-300 PSIA
26636002	Discharge Pressure Transducer, 0-500 PSIA
20966801	Temperature Transmitter w/ 8"x14' 100ohm RTD
20966802	8"x14' 100ohm RTD
331021051	Differential Pressure Switch, 0-45 PSID
2920580201	Refrigerant Pressure Relief Valve, 400PSIG, Air-cooled Chiller (1-4 ton)
2920581001	Refrigerant Pressure Relief Valve, 400PSIG, Air-cooled Chiller (5-7.5 ton)
2920581301	Refrigerant Pressure Relief Valve, 400PSIG, Air-cooled Chiller (10 and 13 ton)
2920580202	Refrigerant Pressure Relief Valve, 350PSIG, Water-cooled Chiller (1.5-5 ton)
2920581302	Refrigerant Pressure Relief Valve, 350PSIG, Water-cooled Chiller (7.5-15 ton)
2920940902	Filter Dryer, 1.5-3 ton
2920941302	Filter Dryer, 4-7.5 ton
2920941802	Filter Dryer, 10-15 ton
29213106	TXV 3 ton Water- and Air-cooled
29213107	TXV 5 ton Water- and Air-cooled
29213108	TXV 7.5 ton Water- and Air-cooled
29213109	TXV 10 ton Water- and Air-cooled

RECOMMENDED SPARE PARTS

Part Number	Description
20958401	Liquid Line Solenoid Valve, 1-5 ton
20958402	Liquid Line Solenoid Valve, 7.5-10 ton
20958403	Liquid Line Solenoid Valve, 13-15 ton
20958404	Hot Gas Bypass Solenoid, 1.5-4 ton
20958405	Hot Gas Bypass Solenoid, 5-10 ton
20958406	Hot Gas Bypass Solenoid, 13 and 15 ton
3331302203	Air Filter, 7.5 and 10 ton Air-cooled

