

USER GUIDE
UGD057-0317

MDCW Carousel Plus Dryer

MDCW Models 15, 25, 50, 75 and 100
with DC-A Control



Please record your equipment's model and serial number(s) and the date you received it in the spaces provided.

It's a good idea to record the model and serial number(s) of your equipment and the date you received it in the User Guide. Our service department uses this information, along with the manual number, to provide help for the specific equipment you installed.

Please keep this User Guide and all manuals, engineering prints, and parts lists together for documentation of your equipment.

Date:

Manual Number: UGD057-0317

Serial Number(s):

Model Number(s):

Display Menu Version:

Control Version:

DISCLAIMER: Conair shall not be liable for errors contained in this User Guide or for incidental, consequential damages in connection with the furnishing, performance or use of this information. Conair makes no warranty of any kind with regard to this information, including, but not limited to, the implied warranties of merchantability and fitness for a particular purpose.

Table of Contents

1 - 1 Introduction

Purpose of the User Guide	1-2
How the Guide Is Organized.....	1-2
Your Responsibility as a User	1-2
ATTENTION: Read This So No One Gets Hurt	1-3
How to Use the Lockout Device	1-4

2 - 1 Description

What is the MDCW Carousel Plus Dryer?	2-2
Optional Self-Loading MDCW	2-2
Typical Applications.....	2-2
How It Works	2-4
How Conveying Works.....	2-5
Specifications: MDCW Carousel Plus Dryers	2-6
MDCW Carousel Plus Dryer Options.....	2-7

3 - 1 Installation

Unpacking the Boxes.....	3-2
Preparing for Installation	3-3
Installing the MDCW	3-4
Connecting Conveying Lines.....	3-5
Connecting the Demand Sensor	3-5
Mounting a Loader on the Hopper.....	3-6
Connecting Material Lines for Self-Loading (optional)	3-6
Connecting the Main Power.....	3-7
Connecting Compressed Air for Self-Loading (optional).....	3-7
Checking for Proper Air Flow	3-8
Connecting the Aftercooler	3-9
Testing the Installation.....	3-10
Using Communications (optional)	3-11

4 - 1 Operation

The MDCW Dryer: Control Panel DC-A	4-2
Control Function Flow Charts.....	4-2
Control Function Descriptions.....	4-8
To Start Drying	4-17
To Stop Drying.....	4-18
Using the The Self-loading Function on the Hopper Loader (optional).....	4-18
Machine Loader Conveying	4-19
How to Log In.....	4-20
Using the Auto Timer	4-20
Setting High Setpoint Limits	4-21
Using Dewpoint Control.....	4-21
Using the Energy Use Monitor.....	4-22
Using the Setback Feature.....	4-22
Setback Feature Guidelines	4-23
Automatic Cleaning Cycle	4-24

5 - 1 Maintenance

Preventative Maintenance Schedule	5-2
Checking the Dewpoint	5-3
Cleaning the Hopper.....	5-3
Clean the Process Filter.....	5-4
Cleaning the Regeneration Filters	5-4
Cleaning the Conveying Filter	5-5
Cleaning the Vacuum Receiver	5-5
Screen Filter Cleaning (optional)	5-6
Cleaning the Compressed Air Filter (optional).....	5-7
Cleaning the Aftercooler Coils.....	5-7
Cleaning the Precooler Coils.....	5-8
Inspecting Hoses and Gaskets.....	5-8
Cleaning and Servicing the Desiccant Rotor.....	5-9

6-1 Troubleshooting

Before Beginning.....	6-2
A Few Words of Caution.....	6-3
Identifying the Cause of a Problem	6-3
Shutdown Alarms	6-4
Passive Alarms.....	6-8
Poor Material Drying Troubleshooting	6-15
Replacing Fuses.....	6-20
Checking or Replacing Temperature Sensors	6-20
Replacing the Heaters	6-22
Replacing the Desiccant Wheel Assembly	6-24
A Appendix	
Customer Service Information	A-1
Warranty Information.....	A-2
B Appendix	
Cleaning the Precooler Coils.....	B-1
C Appendix	
Modbus Communications	C-1
Modbus Address List.....	C-3
D Appendix	
Optional Memory Backup Module.....	D-1
E Appendix	
Changing the IP Address on a DC-A Dryer	E-1
F Appendix	
Virtual Network Computing.....	F-1

Introduction

Purpose of the User Guide	1-2
How the Guide Is Organized	1-2
Your Responsibility as a User	1-2
ATTENTION: Read This So No One Gets Hurt.....	1-3
How to Use the Lockout Device	1-4

Purpose of the User Guide

This User Guide describes the Conair MDCW Carousel Plus Series Dryers and explains step-by-step how to install and operate this equipment.

Before installing this product, please take a few moments to read the User Guide and review the diagrams and safety information in the instruction packet. You also should review manuals covering associated equipment in your system. This review won't take long, and it could save you valuable installation and operating time later.

How the Guide is Organized

Symbols have been used to help organize the User Guide and call your attention to important information regarding safe installation and operation.



Symbols within triangles warn of conditions that could be hazardous to users or could damage equipment. Read and take precautions before proceeding.



Numbers indicate tasks or steps to be performed by the user.



A diamond indicates the equipment's response to an action performed by the user or a situation.



An open box marks items in a checklist.



A circle marks items in a list.



Indicates a tip. A tip is used to provide you with a suggestion that will help you with the maintenance and the operation of this equipment.



Indicates a note. A note is used to provide additional information about the steps you are following throughout the manual.

Your Responsibility as a User

You must be familiar with all safety procedures concerning installation, operation, and maintenance of this equipment. Responsible safety procedures include:

- Thorough view of this User Guide, paying particular attention to hazard warnings, appendices, and related diagrams.
- Thorough review of the equipment itself, with careful attention to voltage sources, intended use, and warning labels.
- Thorough review of instruction manuals for associated equipment.
- Step-by-step adherence to instructions outlined in this User Guide.

ATTENTION: Read This So No One Gets Hurt

We design equipment with the user's safety in mind. You can avoid the potential hazards identified on this machine by following the procedures outlined below and elsewhere in the User Guide.



WARNING: Improper installation, operation, or servicing may result in equipment damage or personal injury.



This equipment should be installed, adjusted, and serviced by qualified technical personnel who are familiar with the construction, operation, and potential hazards of this type of machine.

All wiring, disconnects, and fuses should be installed by qualified electrical technicians in accordance with electrical codes in your region. Always maintain a safe ground. Do not operate the equipment at power levels other than what is specified on the machine serial tag and data plate.



WARNING: Voltage hazard



This equipment is powered by three-phase alternating current, as specified on the machine serial tag and data plate.

A properly sized conductive ground wire from the incoming power supply must be connected to the chassis ground terminal inside the electrical enclosure. Improper grounding can result in severe personal injury and erratic machine operation.

Always disconnect and lock out the incoming main power source before opening the electrical enclosure or performing non-standard operating procedures, such as routine maintenance. Only qualified personnel should perform troubleshooting procedures that require access to the electrical enclosure while power is on.



CAUTION: Hot Surfaces

Always protect yourself from hot surfaces inside the dryer and hopper. Also exercise caution around exterior surfaces that may become hot during use. These include the hopper door frame, the exterior of an uninsulated hopper, the return air hose and the dryer's process filter housing and moisture exhaust outlet.



WARNING: Do not place aerosol, compressed gas or flammable materials on or near this equipment.

The hot temperatures associated with the drying process may cause aerosols or other flammable materials placed on the dryer or hopper to explode.

How to Use the Lockout Device

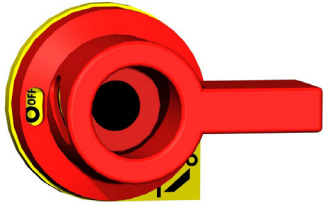

CAUTION: Before performing maintenance or repairs on this product, you should disconnect and lockout electrical power sources to prevent injury from unexpected energization or start-up. A lockable device has been provided to isolate this product from potentially hazardous electricity.

Lockout is the preferred method of isolating machines or equipment from energy sources. Your Conair product is equipped with the lockout device pictured below. To use the lockout device:



1 Stop or turn off the equipment.

2 Isolate the equipment from the electric power. Turn the rotary disconnect switch to the OFF, or "O" position.

3 Secure the device with an assigned lock or tag. Insert a lock or tag in the holes to prevent movement.

4 The equipment is now locked out.



WARNING: Before removing lockout devices and returning switches to the ON position, make sure that all personnel are clear of the machine, tools have been removed and all safety guards reinstalled.



NOTE: The lockout device supplied on your dryer may not appear identical to the one shown here. Illustration is for reference only.

Description

What is the MDCW Carousel Plus Dryer? 2-2

Optional Self-Loading MDCW..... 2-2

Typical Applications 2-2

How It Works 2-4

How Conveying Works 2-5

Specifications: MDCW Carousel Plus Dryers..... 2-6

MDCW Carousel Plus Dryer Options 2-7

What is the MDCW Carousel Plus Dryer?

The MDCW Carousel Plus Dryer is a self-contained, mobile unit designed to dry plastic resin and convey it with dehumidified air directly to a processing machine. This mobile unit contains:

- A mobile dehumidifying dryer
- Drying hopper with a material distribution box
- Conveying blower and filter (optional)
- Direct feed machine loader with a demand sensor
- Hopper loader (with self-loading option)
- Quick disconnect conveying hoses

The dryer produces hot, low dewpoint air that removes moisture from hygroscopic plastics. When the conveying function is turned on, the conveying blower conveys the dried resin to the machine loader mounted on the processing machine. The demand sensor on the machine loader viewing chamber allows you to convey just enough material to satisfy the shot size required for your process.

Optional Self-Loading MDCW

The self-loading option on the MDCW Carousel Plus Dryer allows the conveying blower to convey new material from the material source into the drying hopper on the MDCW. This option is in addition to the standard conveying capability on an MDCW, which is conveying material to the machine from the drying hopper. This option allows the MDCW to be a totally self-contained system with a common control.

Typical Applications

The MDCW Carousel Plus Dryer was designed for drying and conveying beside the press. But it can also be used to pre-dry material in one location, and then transport the dried material to another location for conveying into the processing machine.



Typical Applications (continued)

The MDCW can be used successfully in applications that require:

- A contamination-free drying environment.
- Drying temperatures of 100° to 375°F {38° to 191°C} (or 150° to 375°F {66° to 191°C} without pre-cooler).
- Throughput rates of 15 to 100 lbs {6.8 to 45.4 kg} per hour (some materials can be run at a higher rate).
- Dew points of -40°F {-40°C}.
- Conveying material at distances up to, but not more than, 8 feet {2.4 m} vertically and 6 feet {1.8 m} horizontally. (The long haul option allows conveying material at distances up to, but not more than, 15 feet {4.6 m} vertically and 50 feet {15.2 m} horizontally.)

 **NOTE:** Throughput rates will vary by MDCW model and type of material. [See the Specification pages for throughput ranges.](#)

The MDCW Carousel Plus Dryer can be used successfully in applications that require:

- A contamination-free drying environment
- Drying temperatures within the ranges shown in the following table:

Model	Drying Temperature Range
Low temperature (with pre-cooler)	100° - 150°F {38° - 66°C}
Standard High heat (with after-cooler)	150° - 375°F {66° - 191°C}
Low-high (with after-cooler & pre-cooler)	100° - 375°F {38° - 191°C}

- Throughput rates of 15 to 100 lbs {6.8 to 37.3} per hour (some materials can be ran at a higher rate).
- Dewpoints of -40°F {-40°C}.

Use the after-cooler when:

- Throughput rates are less than 50% of the dryer's rated capacity.
- You are pre-drying material at temperatures over 150°F {66°C}.

How It Works

■ The Process (Drying) Cycle

The process blower pulls moist air from the top of the drying hopper. The air passes through the process filter and aftercooler, then into the desiccant wheel, where moisture is removed. The now dry air moves through the optional precooler (if installed) and process heater, where it is heated to the drying temperature selected by the operator. The hot, dry air is delivered to the hopper where a spreader cone evenly distributes the air through the material.

■ The Regeneration Cycle

The regeneration blower pulls air through the regeneration filter into the dryer's regeneration heater. The air is heated to 350° F {177° C} before it is pushed into the "wet" section of the wheel. The hot air purges moisture from the desiccant. The moist air is blown out the exhaust at the back of the dryer.

□ The Cooling Cycle

Regenerated desiccant must be cooled before it rotates back into the process cycle. The process blower pushes a small amount of air through the cooling section of the desiccant wheel. The cooling air then passes through the aftercooler and repeats the circuit.

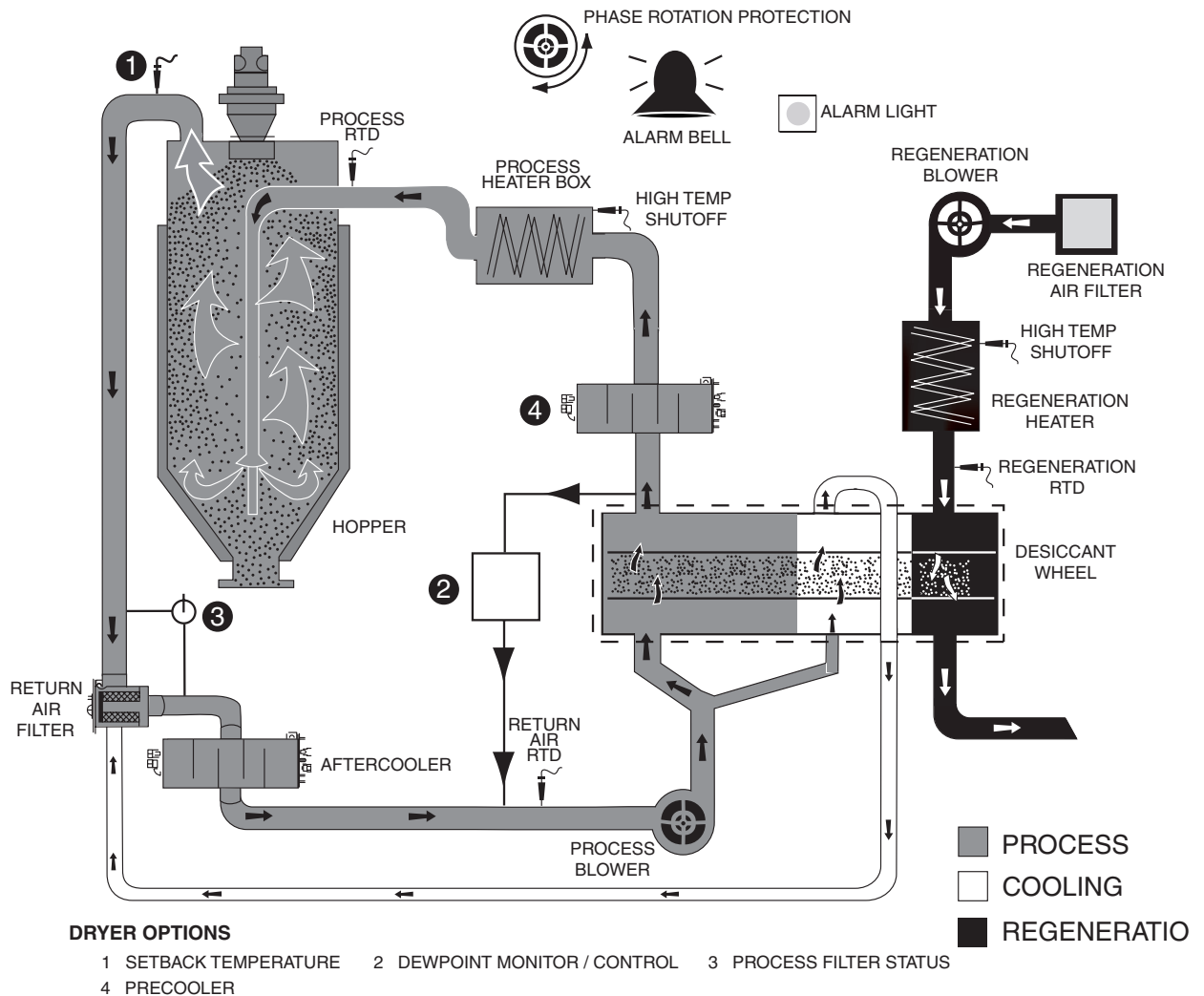

How Conveying Works

-
- The diagram illustrates a conveying system with a drying hopper, a distribution box, a vacuum receiver, and a conveying blower. An orange dotted line traces the path of material from the hopper, through the distribution box, into the vacuum receiver, and back to the hopper. Green lines connect numbered callouts to specific parts of the system.
- 1** Dry material drops into the distribution box when the slide gate on the drying hopper is opened.
 - 2** When the conveying function is turned on, the conveying blower starts.
 - 3** Positive and negative air flow generated by the blower moves the material from the distribution box beneath the drying hopper to the vacuum receiver.
 - 4** Material enters the vacuum receiver and falls into the receiver and viewing chamber. The blower pulls air through the vacuum receiver filter into the return air conveying line.
 - 5** The conveying blower runs until the load time set at the MDCW control is reached. When the material level drops below the demand sensor, the sensor signals for more material. The conveying blower turns on again.
 - 6** The filter traps dust and fines before the returning air reaches the blower.

Specifications: MDCW Carousel Plus Dryers

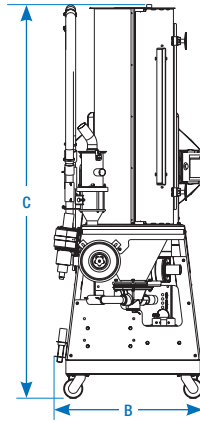
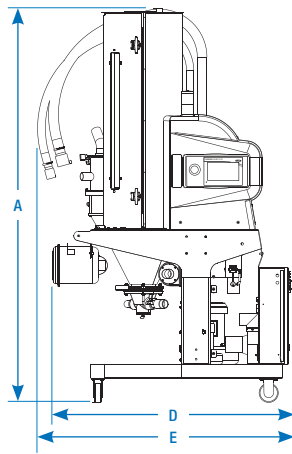

TLR Tube Loader (machine loader) TLR Tube Loader (hopper loader)

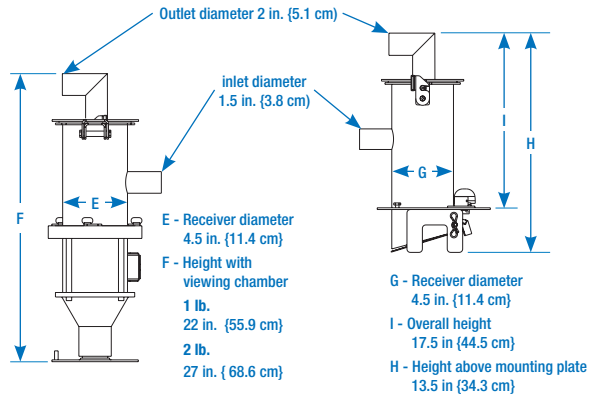

Models	MDCW15	MDCW25	MDCW50	MDCW75	MDCW100
Standard hopper models	RWH14-2	RWH14-3	RWH18-6	RWH24-9	RWH24-12
Optional hopper models	N/A	RWH14-4	N/A	RWH24-12	RWH24-18
Performance characteristics (with full hopper)					
Drying temperature	150 - 375°F {66 - 191°C} with options				
Dewpoint	-40°F {-40°C}				
Standard conveying distance	8 ft {2.44 m} vertical; 6 ft {1.83 m} horizontal				
Long distance conveying option	15 ft {4.57 m} vertical; 50 ft {15.24 m} horizontal				
Dimensions inches {cm}					
A - Height top of conveying pipe	81.9 {208.0}		90.3 {229.4}		
B - Overall width	30.8 {78.2}		43.2 {109.7}		
C - Height to top of hopper (standard)	60.9 {154.7}	74.2 {188.5}	91.1 {231.4}	85.5 {217.2}	93.5 {237.5}
C - Height to top of hopper (optional)	N/A	81.9 {208.0}	N/A	93.5 {237.5}	117.4 {298.2}
D - Depth	45.9 {116.6}		59.0 {149.9}		
E - Overall depth	53.5 {139.9}		60.8 {154.4}		
Drying outlet/inlet tube size OD inches {cm}	2.5 {6.35}				
Approximate weight lbs {kg}					
Standard dryer installed	500 {227}	550 {250}	600 {272}	675 {306}	750 {340}
Standard dryer shipping	695 {315}	700 {318}	790 {358}	815 {370}	950 {431}
Voltage - Total amps** {standard/long conveying distance}					
208 V/3 phase/60 Hz	17.0/21.0		21.9/25.9	28.4/32.4	N/A
230 V/3 phase/60 Hz	15.3/18.9		19.8/23.4	25.6/29.2	26.8/30.4
400 V/3 phase/50 Hz*	8.6/9.7		11.1/12.2	14.4/15.5	14.6/15.7
460 V/3 phase/60 Hz	7.6/9.4		9.8/11.6	12.7/14.5	13.3/15.1
575 V/3 phase/60 Hz	6.0/7.6		7.89.4	10.1/11.7	10.6/12.2
Total kilowatts† kw {std./long}	4.1/5.0		5.3/6.2	6.1/7.0	6.4/7.3
Water requirements {for aftercooler or optional precooler}‡					
Recommended temperature [§]	45° - 85°F {7.2° - 29.4°C}				
Water flow gal./min. {liters/min.}	1 {4.6}		2 {9.1}		
Water connections NPT	3/4 inch NPT				

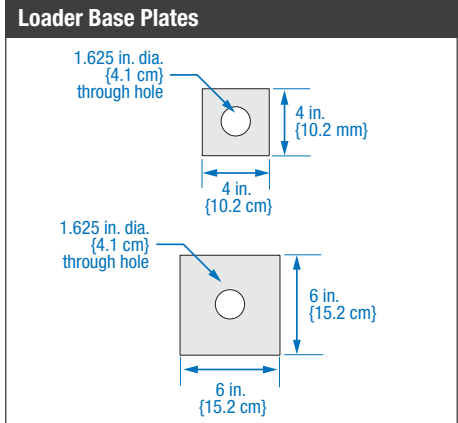

Application Notes

All dryers are supplied with an aftercooler as standard. The aftercooler reduces the temperature of the return air from the drying hopper, improving the efficiency of the desiccant. The aftercooler should be connected with the proper water flow rate and temperature to attain the optimal throughput.

When to use additional filtration

The standard return air cartridge filter is sized for the airflow of each dryer model and is suited for most applications. You should consider adding an optional dust collector and/or volatile trap if:

- The material contains excessive fines. An additional dust collector or cyclone will extend time between filter cleaning.
- The material produces volatiles during drying which condense into a waxy or oily residue. A volatile trap will help to protect the desiccant.

Specification Notes

* Dryers running at 50 Hz will have 17% less airflow, and a 17% reduction in material throughput.
 † Total kW listed at a process setpoint of 250°F and a regeneration temperature of 350°F.
 ‡ When drying below 150°F {66°C} a precooler is required.
 § Temperatures above or below the recommended levels may affect dryer performance. Tower, chiller, or municipal water sources can be used.

** FLA data for reference purposes only. Does not include any options or accessories on equipment. For full FLA detail for power circuit design of specific machines and systems, refer to the electrical diagrams of the equipment order and the nameplate applied to the machine.
 Specifications may change without notice. Consult a Conair representative for the most current information.

MDCW Carousel Plus Dryer Options

- **Volatile trap** (use only in conjunction with aftercooler) - The volatile trap is recommended when drying materials that produce volatiles that condense into a waxy or oily residue and/or if the material contains excessive fines.
- **Precooler** - The precooler reduces the temperature of air flow after the desiccant wheel and before the process heater, enabling the dryer to control temperatures at low setpoints (100 - 150°F {38 - 66°C}).
- **Filter check** - The filter check sensor will activate a passive alarm when the process filter is clogged or needs replaced.
- **Dryer communications** - Allows the dryer to be networked to industrial control systems. Modbus TCP/IP or Ethernet CIP are available.

Installation

Unpacking the Boxes	3-2
Preparing for Installation	3-3
Installing the MDCW	3-4
Connecting Conveying Lines	3-5
Connecting the Demand Sensor	3-5
Mounting a Loader on the Hopper	3-6
Connecting Material Lines for Self-Loading (optional)	3-6
Connecting the Main Power	3-7
Connecting Compressed Air for Self-Loading (optional)	3-7
Checking for Proper Air Flow	3-8
Connecting the Aftercooler	3-9
Testing the Installation	3-10
Using Communications (optional)	3-11

Unpacking the Boxes

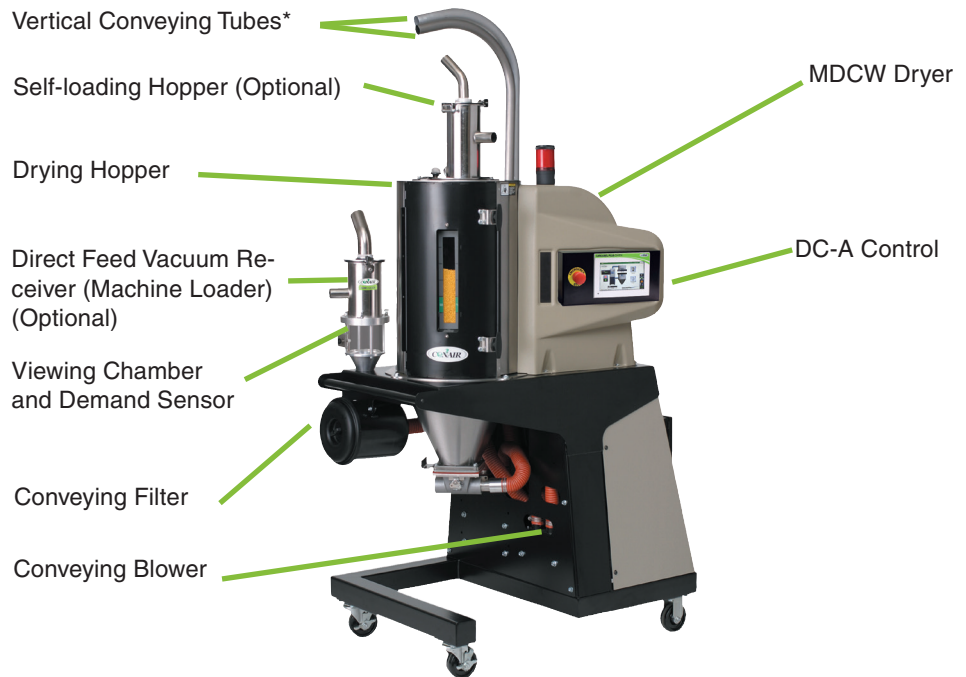

 ***NOTE:** Depending on the model ordered, the vertical conveying tubes may be shipped detached from the unit.

- 1 Carefully remove the dryer and components from their shipping containers,** and set upright. Note that the dryer is secured to its shipping container with two bands and blocking.
- 2 Remove all packing material,** protective paper, tape, and plastic.
- 3 Carefully inspect all components** to make sure no damage occurred during shipping. Check all wire terminal connections, bolts, and any other electrical connections, which may have come loose during shipping.
- 4 Record serial numbers and specifications** in the blanks provided on the back of the User Guide's title page. This information will be helpful if you ever need service or parts.
- 5 You are now ready to begin installation.** Follow the preparation steps on the next page.

Preparing for Installation

The MDCW Carousel Plus Dryer has been designed for use beside the processing machine. The mobile unit can also be used for pre-drying in a remote location.

- 1 Make sure the location for the MDCW provides:
 - A grounded power source supplying the correct current for your dryer model.** Check the dryer's serial tag for the correct amps, voltage, phase and cycles. Field wiring should be completed by qualified personnel to the planned location for the dryer. All electrical wiring should comply with your region's electrical codes.
 - A source of water, for the aftercooler or optional precooler.** The dryer's aftercooler and optional precooler requires 2 gals./min {7.6 liters/min} tower or city water at temperatures of 40° to 85°F {4° to 29°C}. Piping should be ran to the planned dryer location. Use flexible hose to connect the water pipes to the aftercooler or optional precooler.
- 2 **Mount the vacuum receiver mounting bracket.** Lay out the bolt pattern of the processing machine feed throat on the blank base plate of the vacuum receiver mounting bracket and gasket. Drill holes for the mounting bolts you plan to use. Place the gasket between the feed throat and mounting bracket. Bolt the mounting bracket to the feed throat.

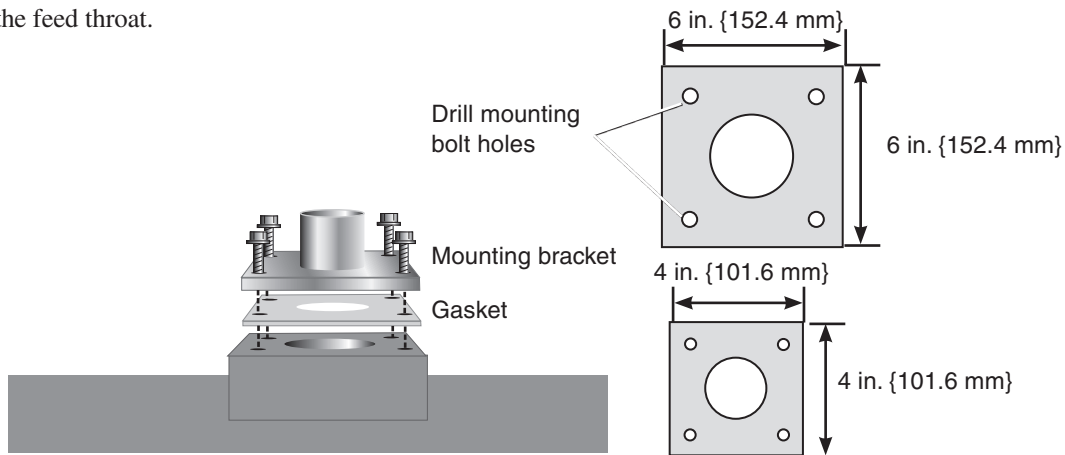

NOTE: You will receive either a 4x4 inch {102 x 102 mm} or 6x6 inch {152 x 152 mm} mounting bracket, depending on the dryer model you have ordered. The mounting bracket is specified on your order. If you need a larger mounting bracket, call Conair Parts at 1-800-458-1960.

Installing the MDCW

Tools for installation:

- Phillips screwdriver*
- Flathead screwdriver*

The MDCW was designed to be mobile. When you move the MDCW, you will need to mount the vacuum receiver, connect the main power source, connect a water source for the aftercooler and/or optional precooler, and connect a compressed air source for the optional self-loading hopper loader. Phasing of electric power should be consistent between locations. The MDCW has built-in phase detection and will not allow the unit to operate if the phasing is incorrect.

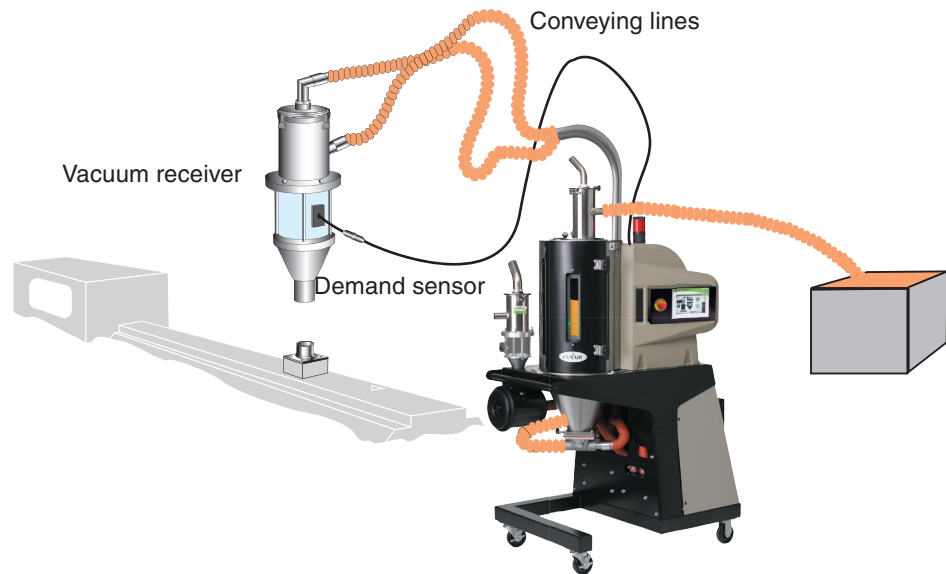

Demand Sensor Connection



The first time you install the MDCW:

- 1** Move the MDCW to the processing area. Lock the wheels on the drying cart.
- 2** Mount the vacuum receiver on the feed throat. Push the vacuum receiver onto the mounting bracket.
- 3** Connect the conveying lines.
- 4** Connect the demand sensor to the connection on the dryer frame.
- 5** Connect the main power source.
- 6** Connect a source of water for the aftercooler and/or optional precooler.

Connecting Conveying Lines

The vertical conveying tubes and flexible conveying hoses may have been removed for shipping. To assemble:

- 1 Insert each vertical conveying tube into its quick disconnect fitting on the MDCW.** Push the tube down until you feel it seat snugly inside the disconnect fitting. Tighten the thumb screws on the fittings to secure the tubes.
- 2 Secure flexible conveying hoses to the vertical tubes with hose clamps.** Insert the tube at least 1 inch {2.54 cm} into the flexible hose. Secure the hose clamp at least 1/4 inch {0.64 cm} from the end of the tube.
- 3 Attach the flexible conveying hoses to the appropriate inlet and outlet of the vacuum receiver.** Push the quick disconnect fitting on the material conveying hose over the material inlet tube. Push the quick disconnect fitting on the return air conveying hose over the conveying air outlet of the vacuum receiver. Tighten the thumb screws on the fitting.

 **NOTE:** MDCW with long haul conveying option does not include conveying hose. Conair recommends the use of rigid piping. Material lines = 1½" Ø. Vacuum lines = 2" Ø.

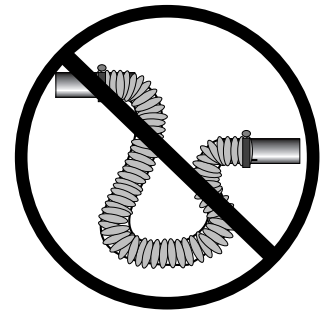
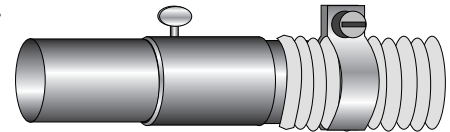
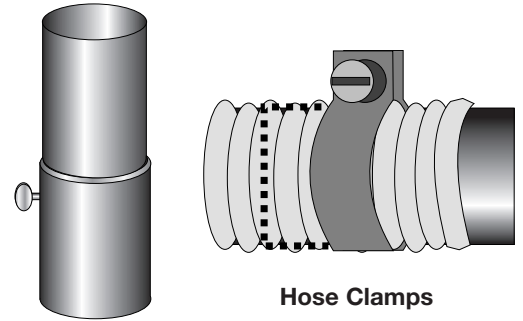

Connecting the Demand Sensor

The capacitive demand sensor monitors the level of material in the viewing chamber of the vacuum receiver when the MDCW is conveying. The sensor signals the MDCW control to start the conveying blower whenever the level of material drops below the amount that you want to maintain at the feed throat.

 **NOTE:** Do not allow the flexible hoses to kink or crimp.

- 1 Plug the sensor cable into the multi-pin connector on the side of the MDCW frame.**

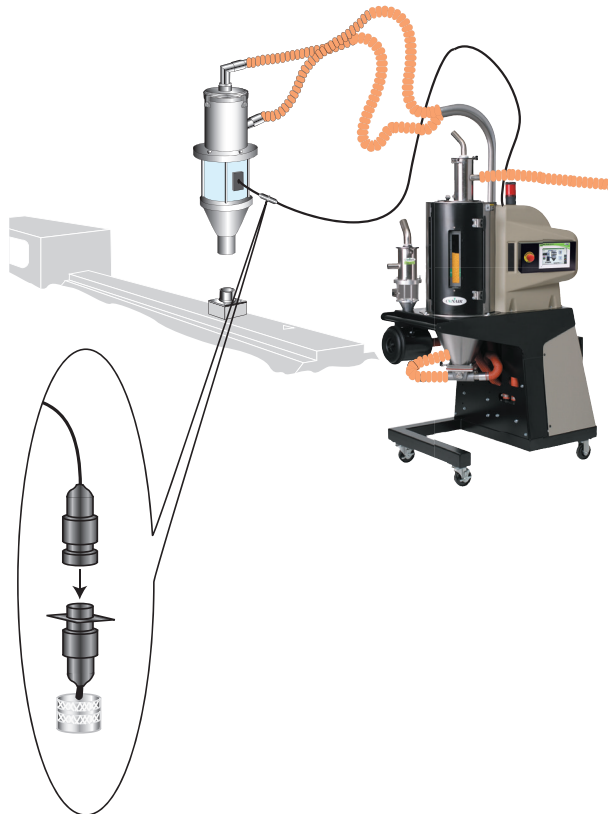

Mounting a Loader on the Hopper

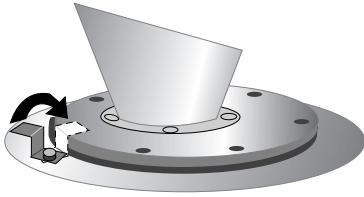

If you have a Conair loader or vacuum receiver, you can use the flange and mounting clips provided on the top of the hopper. Refer to the manuals that came with your receiver or loader for detailed installation instructions.

IMPORTANT: Check to ensure that all material conveying hoses are placed away from the control panel. Static electricity can damage the control circuit.

Connecting Material Lines for Self-Loading (optional)

TIP: Material layering of virgin and regrind material is achieved with an optional ratio valve located at the material inlet of the hopper loader.

When connecting the optional self-loading function of the MDCW Carousel Plus dryer you will need to make several connections for conveying tubes and the demand sensor for the hopper loader.

Ratio valves are available from Conair.

Contact Conair Parts: (800) 458 1960
From outside of the United States, call:
(814) 437 6861.

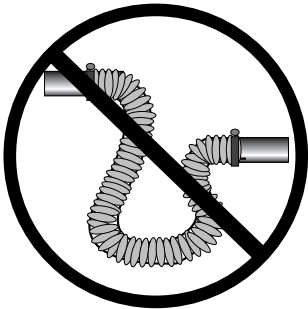

NOTE: Do not allow the flexible hoses to kink or crimp.

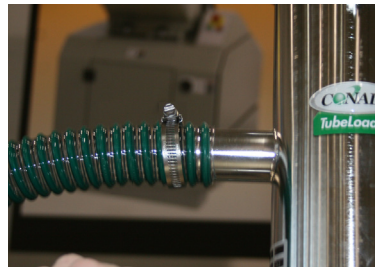

To connect the conveying tubes and demand sensor cables:

1 Mount the loader on top of the hopper. Attach the 10ft. {3.05m} supplied material line to the inlet of the hopper loader. Secure with clamp.



2 Connect a gaylord wand to the material inlet line, then place the wand in your material.



3 Connect the demand sensor to the dryer control box.



4 Attach the air conveying line to the outlet of the hopper loader. Secure with clamp.



5 Connect the air conveying line to the inlet of the pneumatic valve located on the side of the dryer frame. Secure with clamp.

Connecting the Main Power



CAUTION:



Always disconnect and lock out the main power sources before making electrical connections. Electrical connections should be made only by qualified personnel.

- 1** Open the dryer's electrical enclosure by turning the disconnect dial on the dryer door to the Off or "O" position. Lock out the main power (see Page 1-6 for complete lock out information). Turn the captive screw, and swing the door open.
- 2** Insert the main power wire through the knockout in the side of the enclosure. Secure the wire with a rubber compression fitting or strain relief.
- 3** Connect the power wires to the three terminals at the top of the power disconnect.
- 4** Connect the ground wire to the ground lug as shown in the photo.

IMPORTANT: Always refer to the wiring diagrams that came with your dryer before making electrical connections.

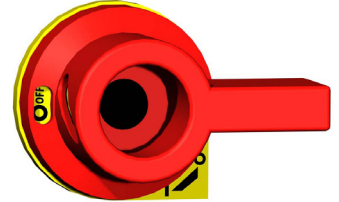

Connecting Compressed Air for Self-Loading (optional)

When connecting the optional self-loading function of the MDCW Carousel Plus dryer an 80 psi {5.5 bar} compressed air source is required.

To connect the compressed air source:

- 1** Install the 1/4 inch NPT adapter to the compressed air outlet found on the left side of the the dryer. Seal adapter threads with nylon tape.
- 2** Attach compressed air hose to the 1/4 inch NPT adapter.



Air Hose Connection

Checking for Proper Air Flow

CAUTION:

Checking for proper air flow must be performed before filling the hopper with material. Performing this step after the hopper is filled with material could cause damage to the dryer if the airflow direction is incorrect due to improper phase connection. Material from the hopper can be pulled into the process heater, causing permanent damage.

- 1 **Turn on the main power to the dryer.** Make sure the dryer's disconnect dial is in the ON position. This powers up the control.

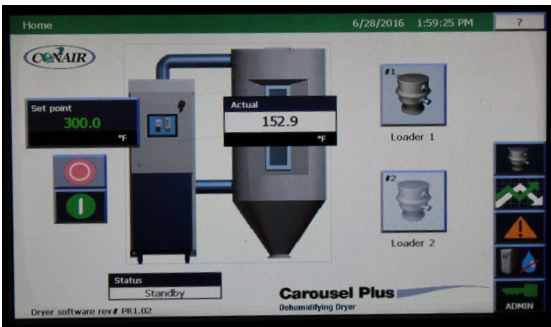

- 2 **Set the drying temperature.** Enter the low setpoint temperature (150° F {66° C}) on the numeric keypad and press enter.

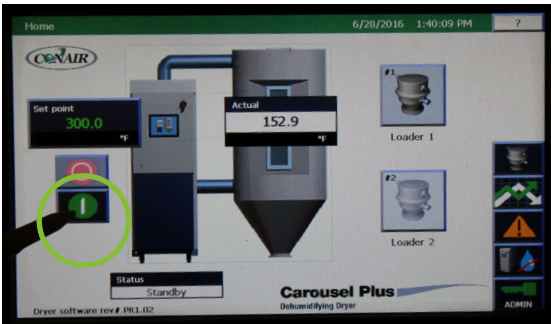

- 3 **Press the START button.** Disconnect the process filter and feel for suction at the inlet to the filter. If the airflow is traveling in the correct direction you should feel suction.

CAUTION: Hot Surface

Do not place your hand directly on the delivery air outlet. The outlet and the air can get hot enough to burn your hand.



- 4 **Press the Stop button.** Reconnect the process filter that was disconnected in Step 3.

Checking for Proper Air Flow (continued)

- 5 **Disconnect the power if the airflow is incorrect**, follow the proper lockout procedure, and swap any two of the three main power wires.



WARNING:

All wiring, disconnects, and fuses should be installed by qualified electrical technicians in accordance with electrical codes in your region. Always maintain a safe ground. Do not operate the equipment at power levels other than what is specified on the machine serial tag and data plate.

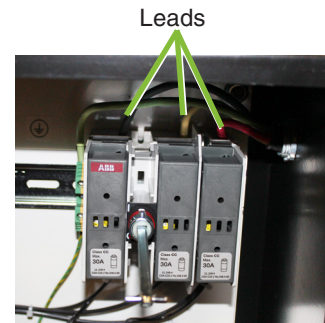
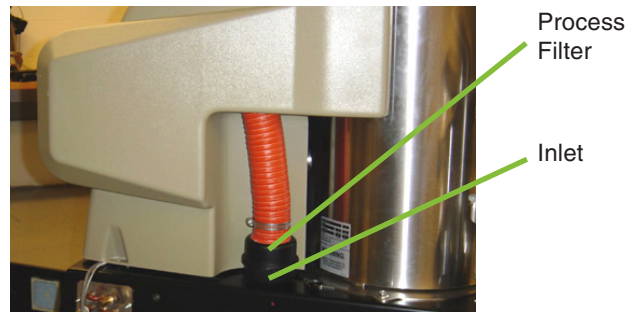

Connecting the Aftercooler

The aftercooler and optional precooler require a source of cooling water and a discharge or return line.

To connect water hoses:

- 1 **Connect the water supply line to the aftercooler inlet.** If a manual shut off valve is used, it should be mounted on the inlet line.
- 2 **Connect the water discharge or return line to the aftercooler outlet.**

 **NOTE:** Water to aftercooler should be turned off when the dryer is not running to prevent condensation.



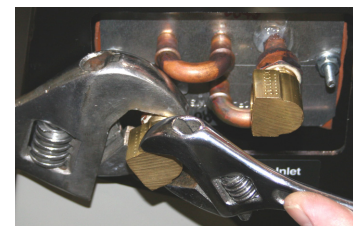

 **TIP:** Make the water supply and discharge / return connections with flexible hoses at least 24 in. (61 cm) long. This allows you to easily remove the aftercooler assembly for cleaning.

 **TIP:** To ensure that the aftercooler's copper piping is not damaged or pinched while installing an adapter, use a wrench to brace the aftercooler piping.

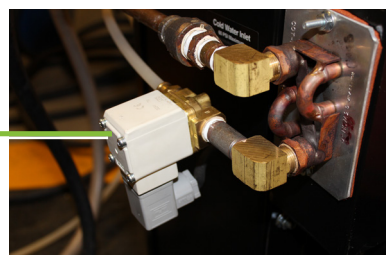

Optional Aftercooler Flow Constant Valve



 **TIP:** If an optional flow control is being installed to the aftercooler, the manual shut off valve should be installed on the inlet line for the flow control.



Testing the Installation

You have completed the installation. Now it's time to make sure everything works.

- 1 Make sure there is no material in the hopper.** If you have mounted a loader or vacuum receiver on the hopper, disconnect the material inlet hose at the source or turn off the loader.
- 2 Turn on the main power to the dryer.** Make sure the dryer's disconnect dial is in the ON position. This powers up the control and the display will illuminate.
- 3 Set the drying temperatures.** Enter a low setpoint temperature (150° F {66° C}) on the numeric keypad and press enter.

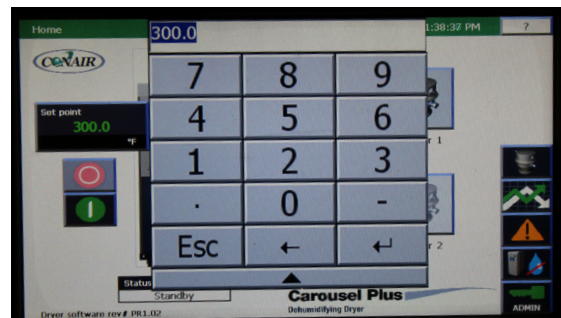
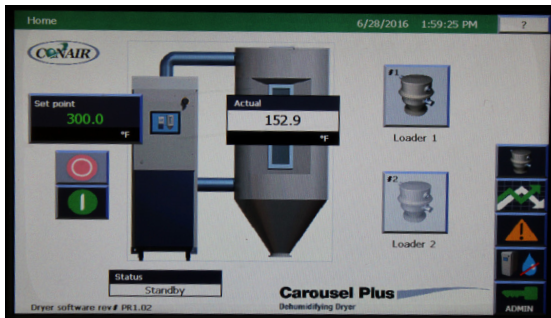

- 4 Press the START button.** If everything is installed correctly:
 - The start button will fade.
 - The process and regeneration blowers will turn on.
 - The process and regeneration heaters will turn on.
 - The status bar will display "Starting".

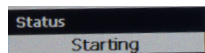

- 5 Turn ON the hopper loader and machine loader by pressing the loader buttons.** The buttons are greyed when loaders are off, and bold when loaders are on.
 - The conveying blowers should turn on.

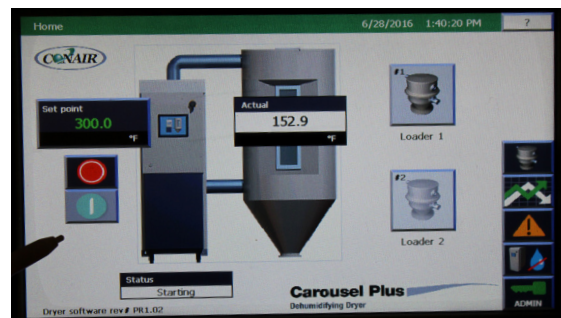
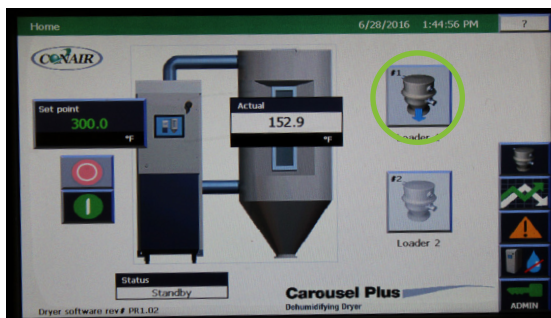

- 6 Press the loader button again to turn the hopper and machine loaders off.**

- 7 Press the STOP button.**
 - The blowers will continue running as needed to cool the heaters (until both heaters are less than 150° F {66° C}).

- 8 The test is over.** If the dryer performed the normal operating sequences as outlined, you can load the hopper and begin operation. If it did not, refer to the Troubleshooting section of the User Guide.

Using Communications (optional)

To use the optional Ethernet, see the Addendum for hardware installation and configuration.

The available protocols are CIP and Modbus TCP/IP.

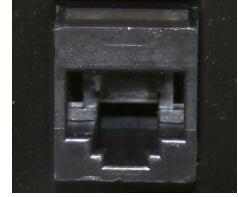

Ethernet Connection

Operation

The MDCW Dryer: Control Panel DC-A	4-2
Control Function Flow Charts	4-2
Control Function Descriptions	4-8
To Start Drying	4-17
To Stop Drying	4-18
Using the The Self-loading Function on the Hopper Loader (optional).....	4-18
Machine Loader Conveying	4-19
How to Log In	4-20
Using the Auto Timer	4-20
Setting High Setpoint Limits	4-21
Using Dewpoint Control	4-21
Using the Energy Use Monitor	4-22
Using the Setback Feature	4-22
Setback Feature Guidelines	4-23
Automatic Cleaning Cycle	4-24

The MDCW Dryer: Control Panel DC-A

Screen Title

Alphanumeric characters display the name of the current screen.

Actual Hopper Temperature

Displays the current process temperature of the hopper in real time.

Current Date and Time

Displays in Month/Day/Year Hour:Minute:Second format.

Drying Setpoint Temperature

Press to bring up numeric keypad to enter data.

Dryer Operation

Press to start and stop.

Dryer Software Version

Displays current software version of the DC-A.

Dryer Status

Displays the current status of the Dryer: Standby, Starting, Running, or Stopping.

Receiver Defaults

#1 fills the hopper. #2 fills the machine. Press to enable or disable. Icons fade when disabled.

Trends

Displays various trend lines (depending on options).

Help

Displays detailed explanations of everything on the current screen.

Loading Settings

Displays current Receiver settings and allows for changes.

Security

Displays the current status of the user. Allows login when pressed. It becomes red when locked.

Dryer Settings

Displays current Dryer settings and allows for changes.

Alarm Log

Alarm list and history

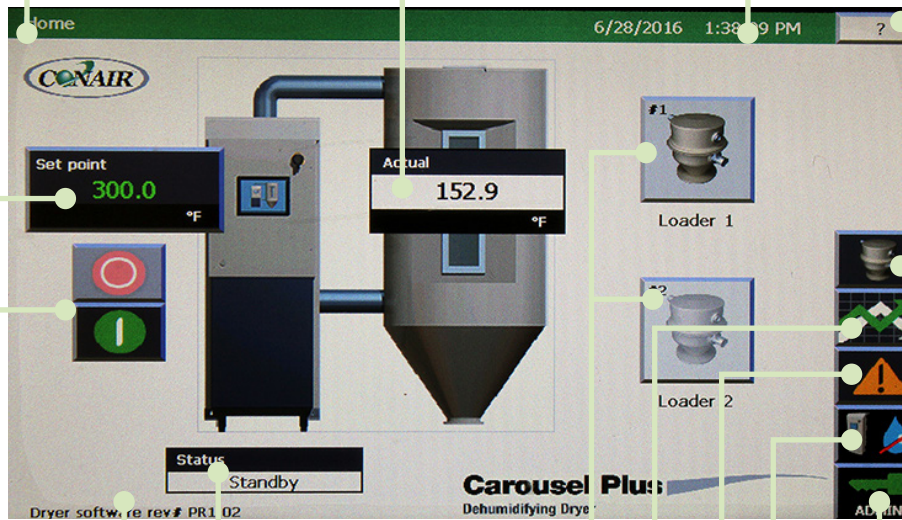

Control Function Flow Charts

The charts beginning on the next pages provide a quick summary of the control functions. For an explanation of each control function, see Control Function Descriptions.

 **NOTE:** In the flow charts of the display screens that follow this page, the screens may display optional functions. If the options were not purchased with the dryer, those functions will not appear. Most options can be purchased and installed in the field.

 **NOTE:** Upon startup, the first time loading each screen may be delayed slightly as the content is loaded. You may notice this mostly on the help screen.

Control Function Flow Charts (continued)

Home

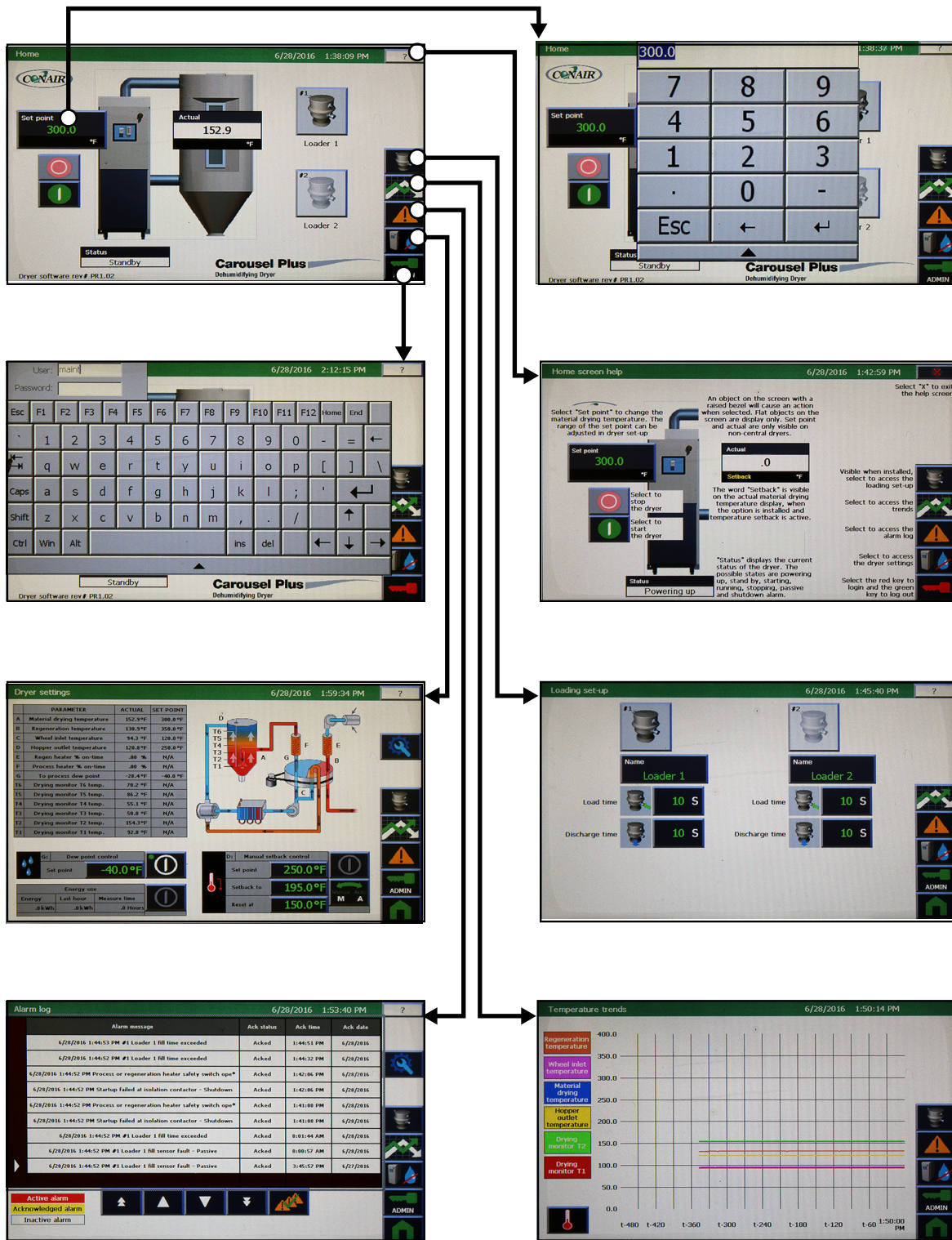

Operation 4

Control Function Flow Charts (continued)

Loader Settings

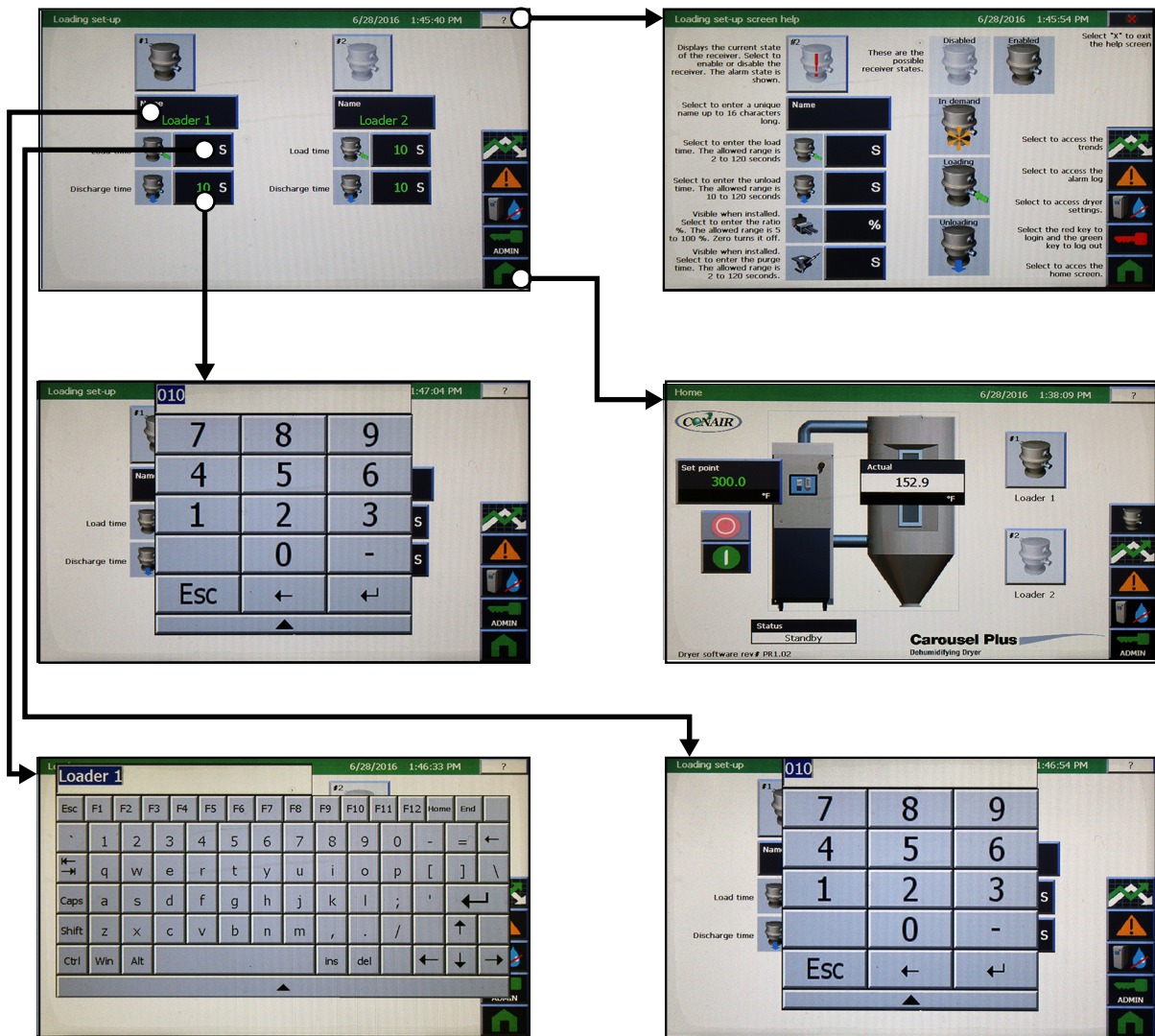

Control Function Flow Charts (continued)

Trends

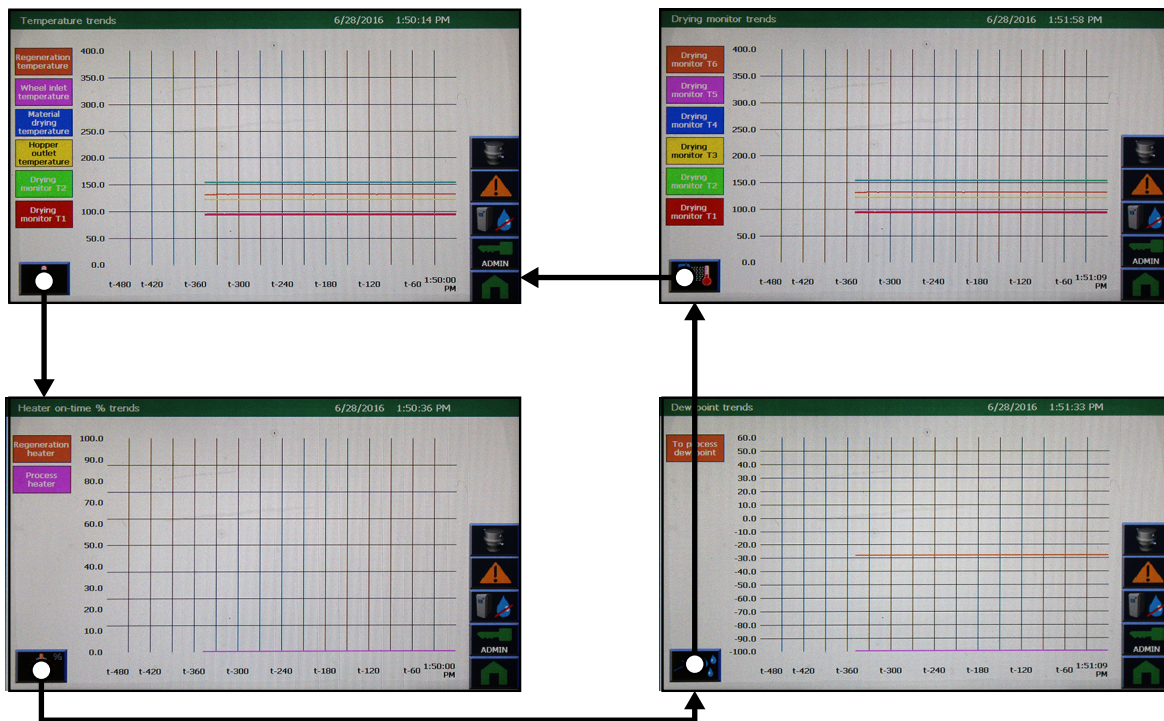

Control Function Flow Charts (continued)

Alarms

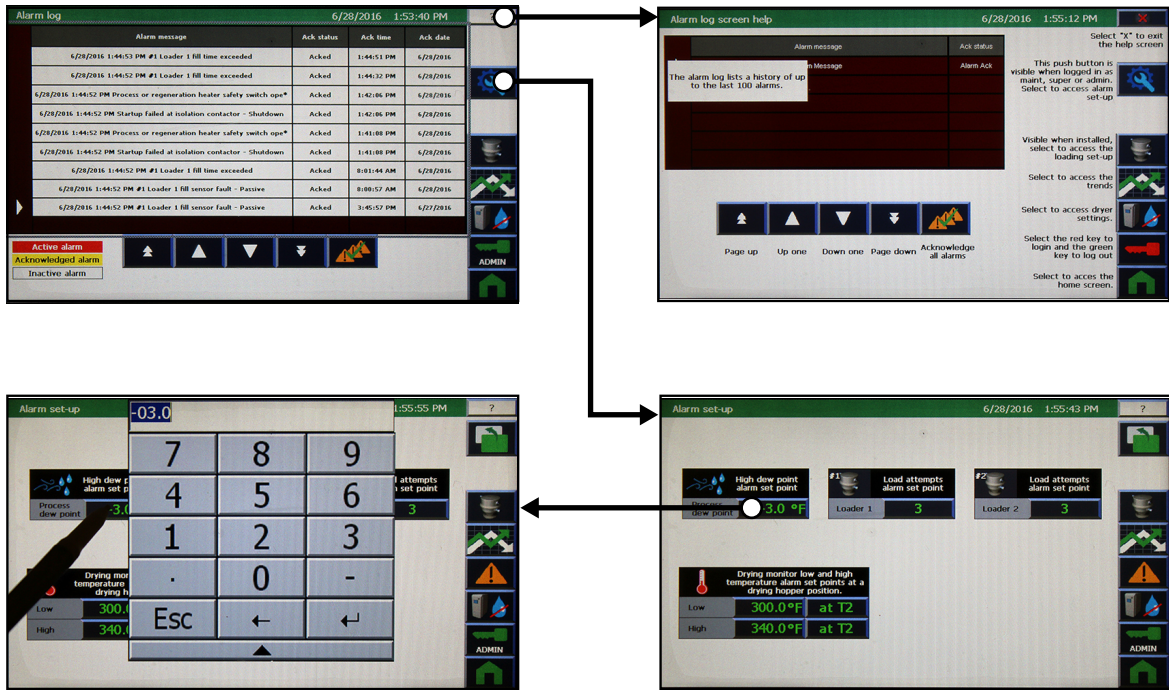

Control Function Flow Charts (continued)

Dryer Settings

Dryer settings 6/28/2016 1:59:34 PM

PARAMETER	ACTUAL	SET POINT
A Material drying temperature	152.3°F	300.0°F
B Regeneration temperature	138.3°F	350.0°F
C Wheel inlet temperature	54.3 °F	120.0°F
D Hopper outlet temperature	128.0°F	250.0°F
E Regen heater % on time	00 %	N/A
F Process heater % on time	00 %	N/A
G To process dew point	-28.4°F	-60.0°F
H Drying monitor T5 temp.	78.2 °F	N/A
I1 Drying monitor T5 temp.	88.2 °F	N/A
J4 Drying monitor T4 temp.	55.1 °F	N/A
K Drying monitor T3 temp.	58.8 °F	N/A
L Drying monitor T2 temp.	154.3°F	N/A
M Drying monitor T1 temp.	52.8 °F	N/A

Control buttons: Dew point control (Set point: -40.0°F), Manual setback control (Set point: 250.0°F, Setback to: 195.0°F, Reset at: 150.0°F), Energy use (Last hour, Measure time).

Dryer settings screen help 6/28/2016 2:09:31 PM

Select "X" to exit the help screen.

The list of dryer settings is display only and will vary depending on the installed features.

When enabled, dew point control varies the regeneration temperature of the wheel to maintain the desired delivery air dew point. The range of the set point is -40 to 40F or -40 to 4.0C. Select the on/off push button to turn the control on or off.

When enabled, the set back control will set the material drying temperature back to the "setback to" value when the air temperature exiting the drying hopper reaches the "Reset at" set point for 2 minutes; the material drying temperature returns to the original value. When the air temperature exiting the drying hopper reaches the "Reset at" set point for 2 minutes; the material drying temperature returns to the original value. In manual all set points are entered manually. In auto the "setback to" and "Reset at" values are calculated. Select the on/off push button to turn the control on or off.

When enabled, the energy meter displays the calculated energy use. The last hour value can be monitored to see if conditions have improved or worsened energy consumption. Select the on/off push button to turn the meter on or off/reset to zero.

Dryer set-up 6/28/2016 2:02:56 PM

31:16 Date and Time

Year: 2016, Month: 6, Day: 28, Hour: 14, Minute: 2, Second: 56

English Metric, °F °C

Auto Start: Day 1, Hour 1, Minute 1

HMI ethernet: IP address 10.1.11.6, Subnet 255.255.255.0, Gateway 10.1.11.1

PLC ethernet: IP address 10.1.11.5, Subnet 255.255.255.0, Gateway 0.0.0.0

Material drying temp. set point: Minimum 150.0°F, Maximum 350.0°F

Reset Password, User password management (Current user: ADMIN, Change Password)

Dryer set-up screen help 6/28/2016 2:03:16 PM

Select "X" to exit the help screen.

The "Auto Start" function will automatically start the dryer at the end of a scheduled shut down, weekend or holiday. Enter the day of the month 1 to 31. Enter the hour of the day 1 to 24. Enter the minutes of the hour 0 to 59 and turn on the function. After starting the auto start automatically resets to off or disabled.

Select the minimum and/or maximum set points to enter the acceptable range for the material drying temperature set point located on the home screen. The range for minimum is -100F/27.7C to maximum. The range for maximum is minimum to 255F/105.5C.

The "Reset Password" push button is only visible when logged in as admin. Select it to reset a users password to a new password, when the old password is unknown.

Select "Change password" to change the password of the user currently logged in. You must enter the old password, a new password and confirm the new password.

I/O test screen help 6/28/2016 2:09:10 PM

Inputs: Emergency stop pushbutton - EM_DI_02, Regen blower auxiliary contact - EM_DI_03, Regen blower overload contact - EM_DI_04, Process blower auxiliary contact - EM_DI_05, Process blower overload contact - EM_DI_06, Isolation auxiliary contact - EM_DI_07, Wheel rotation sensor - EM_DI_08, Phase detection relay - EM_DI_09, Diff. pressure process air filter - EM_DI_10, Diff. pressure regeneration air filter - EM_DI_11, #1 O fill sensor - EM_DI_12, #2 O fill sensor - EM_DI_13.

Outputs: General alarm, Wheel motor, Regen blower, Regen SSR's, Process blower, Process SSR's, Isolation contactor, After cooler sol.

Note: The inputs and outputs available are dependent on the features and options purchased with the dryer.

Dryer I/O test 6/28/2016 2:07:46 PM

Inputs	State
Emergency stop pushbutton - EM_DI_02	Off
Regen blower auxiliary contact - EM_DI_03	On
Regen blower overload contact - EM_DI_04	On
Process blower auxiliary contact - EM_DI_05	On
Process blower overload contact - EM_DI_06	On
Isolation auxiliary contact - EM_DI_07	On
Wheel rotation sensor - EM_DI_08	On
Phase detection relay - EM_DI_09	On
Diff. pressure process air filter - EM_DI_10	On
Diff. pressure regeneration air filter - EM_DI_11	On
#1 Loader 1 fill sensor - EM_DI_12	On
#2 Loader 2 fill sensor - EM_DI_13	On
#1 Loader 1 demand sensor - P2_DI_00	On
#2 Loader 2 demand sensor - P2_DI_01	On
Conveying blower overload contact - P2_DI_02	On
Downstream machine running - P2_DI_03	On

Outputs: Alarm light red, Wheel motor, Regen blower, Regen SSR's, Process blower, Process SSR's, Isolation contactor, After cooler sol.

Control Function Descriptions

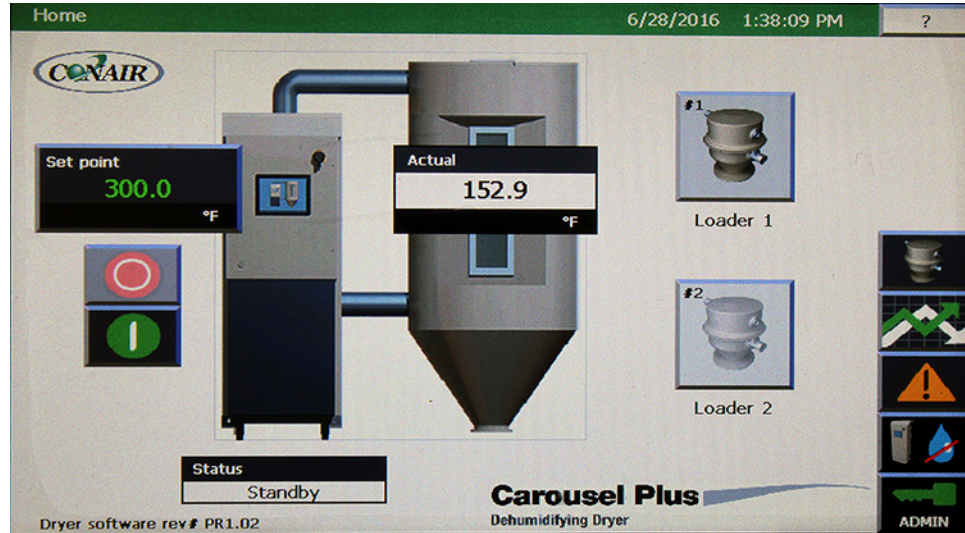

Home Screen

The home screen conveniently displays all information for typical operation. From here, you can view the current Actual temperature, set the Set point, view the dryer status, Start and Stop drying, and Start and Stop conveying. The Help screen will give you information to help with operating the dryer from this screen. The menu buttons on the right allow for navigation to other areas of the dryer control.

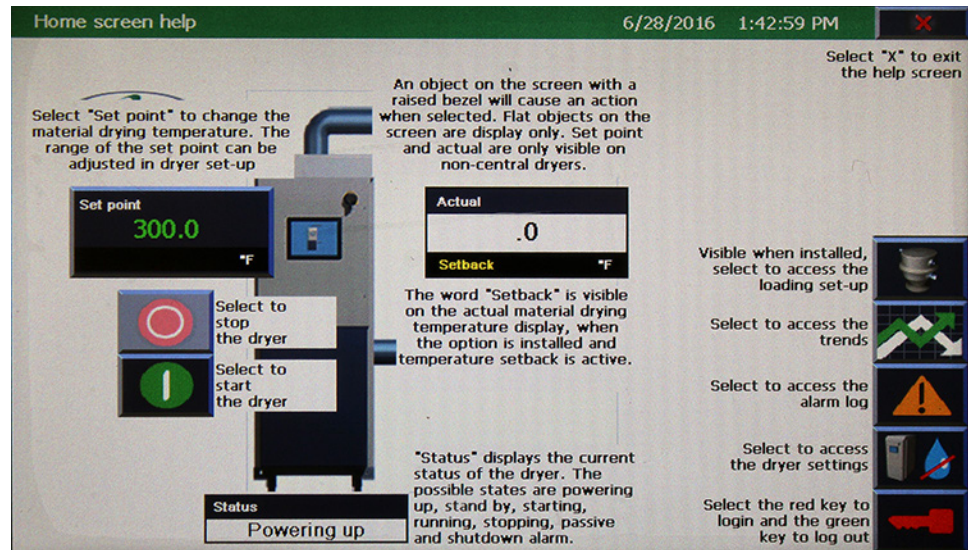

Help Screen – Home

This screen displays helpful information about the dryer home screen.

Control Function Descriptions

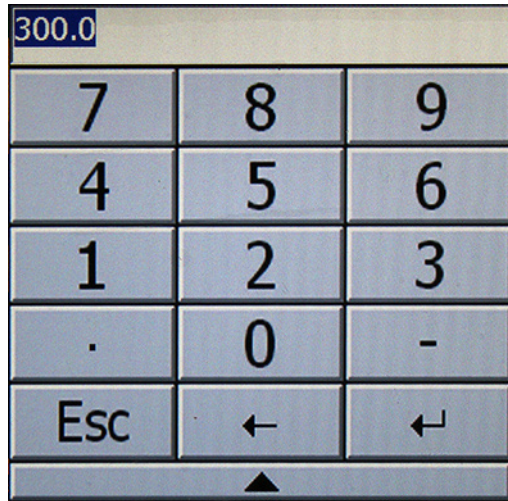

Number Pad Pop-up

This number pad will pop up when you've selected a setpoint or variable that can be adjusted. Enter your desired setting, followed by the enter key. Press the delete key (arrow left) to delete a number, or the ESC key to leave the number pad without making any changes.

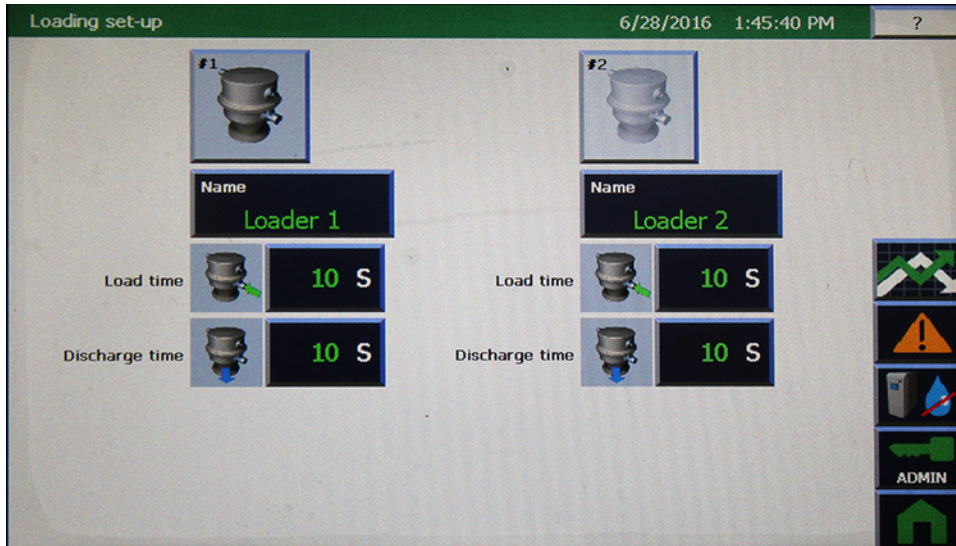

Loading Set-up Screen

This screen allows you to enable and disable loaders, and to change the loader names, load times, and discharge times. Pressing on the loader icon will enable and disable the loader. Pressing on the loader name box will allow for customizing the loader name. Pressing on the load time and discharge time boxes will allow for changes to the times (in seconds).

Control Function Descriptions

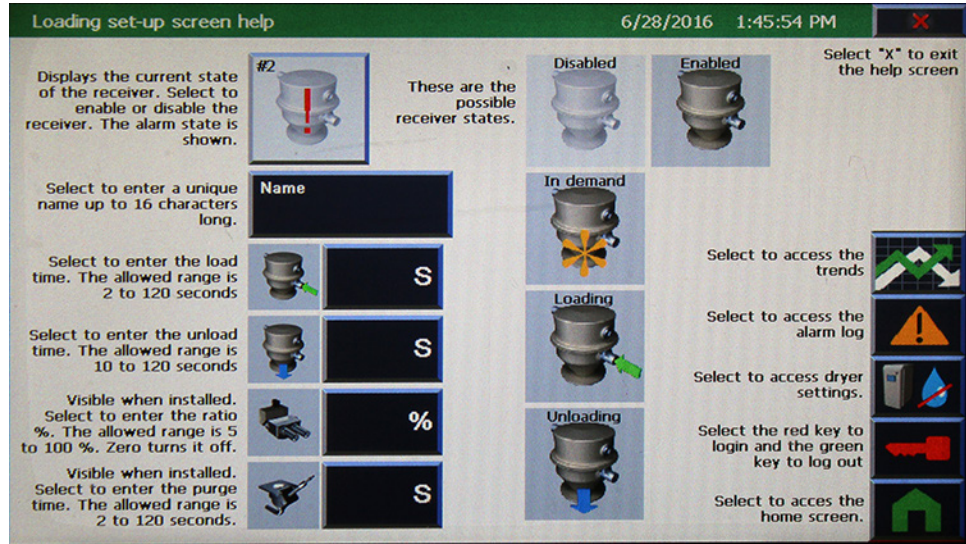

Help Screen – Loading Set-up

This screen will help with setup options on the Loading Setup screen. It notes limits to ranges and other important information.

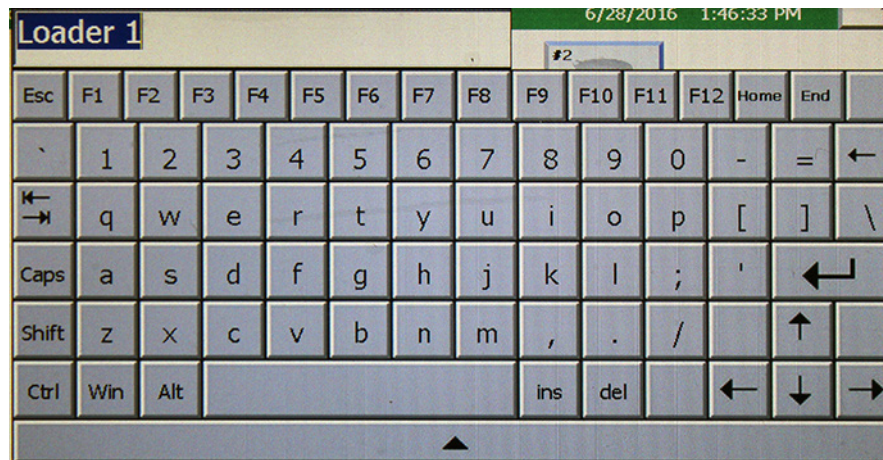



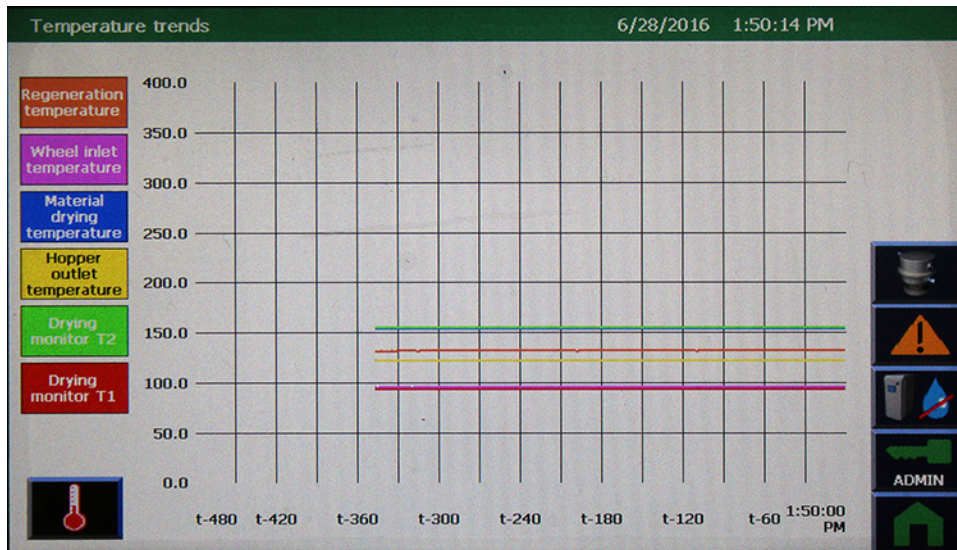

Alphanumeric Pad Pop-up

This keypad will pop up whenever an editable text box is pressed. This box allows for entering user names, passwords, loader names, etc. Press the Enter key once changes are made, or the ESC key to exit the screen without making changes.

Control Function Descriptions



-  Temperature Trend
-  Heater On-Time % Trend
-  Dewpoint Trend
-  Drying Monitor Temperature Trend

Trend Screens

From these four screens, you can view the Temperature Trend, Drying Monitor Temperature Trend (if equipped), Heater On-Time % Trend, and Dewpoint trend. These trending screens can help you optimize performance, and note issues you may be having with you dryer.

Alarm message	Ack status	Ack time	Ack date
6/28/2016 1:44:53 PM #1 Loader 1 fill time exceeded	Acked	1:44:51 PM	6/28/2016
6/28/2016 1:44:52 PM #1 Loader 1 fill time exceeded	Acked	1:44:32 PM	6/28/2016
6/28/2016 1:44:52 PM Process or regeneration heater safety switch ope*	Acked	1:42:06 PM	6/28/2016
6/28/2016 1:44:52 PM Startup failed at isolation contactor - Shutdown	Acked	1:42:06 PM	6/28/2016
6/28/2016 1:44:52 PM Process or regeneration heater safety switch ope*	Acked	1:41:08 PM	6/28/2016
6/28/2016 1:44:52 PM Startup failed at isolation contactor - Shutdown	Acked	1:41:08 PM	6/28/2016
6/28/2016 1:44:52 PM #1 Loader 1 fill time exceeded	Acked	8:01:44 AM	6/28/2016
6/28/2016 1:44:52 PM #1 Loader 1 fill sensor fault - Passive	Acked	8:00:57 AM	6/28/2016
6/28/2016 1:44:52 PM #1 Loader 1 fill sensor fault - Passive	Acked	3:45:57 PM	6/27/2016

Alarm Log Screen

This screen displays the 100 most recent alarms. It allows you to navigate through the alarm list for more detail, acknowledge all alarms, and change alarm settings.

Control Function Descriptions

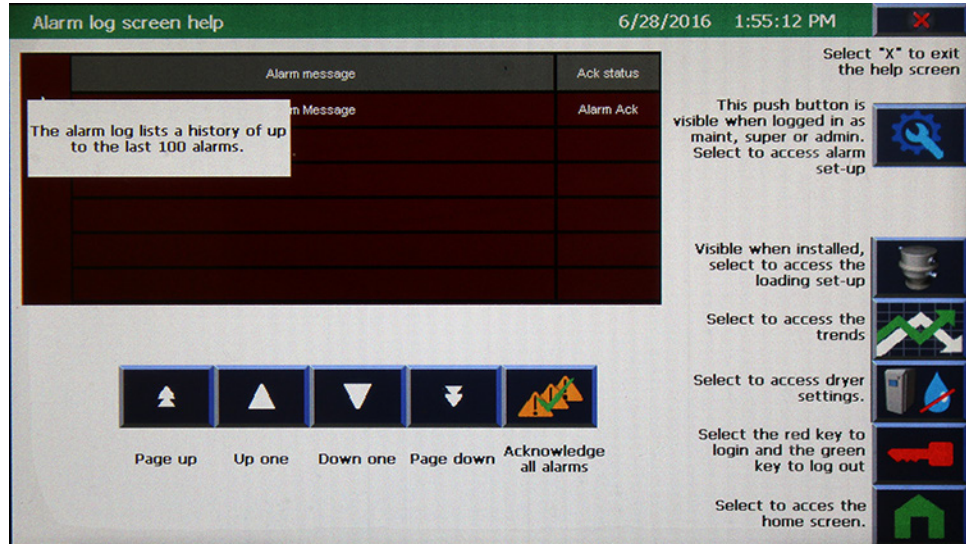

Help Screen – Alarm Log

This screen shows detailed help information for the Alarm Log Screen.

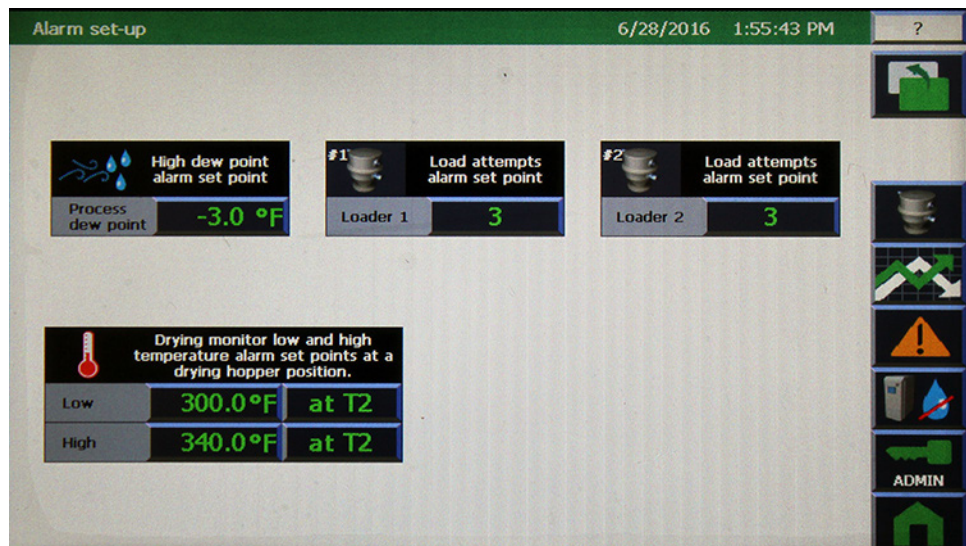

Alarm Set-up Screen

From the Alarm Log Screen, pressing the Setup button takes you to this screen, where you can make adjustments to the user settings which trigger an alarm condition.

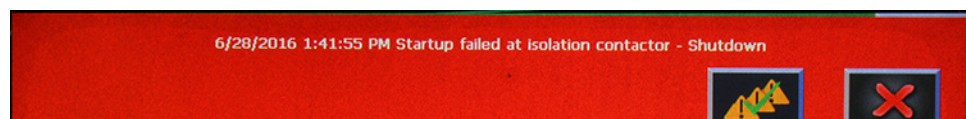

Alarm Banner

The alarm banner will appear on the screen in the event of an alarm that needs addressed by the operator. The banner will give a description of the problem, and the type of alarm. The alarm can be acknowledged here, and the banner can be closed. You can also view the alarm list on the Alarm page.

Control Function Descriptions

Dryer settings 6/28/2016 1:59:34 PM ?

PARAMETER	ACTUAL	SET POINT
A Material drying temperature	152.9°F	300.0°F
B Regeneration temperature	130.9°F	350.0°F
C Wheel inlet temperature	94.3 °F	120.0 °F
D Hopper outlet temperature	120.8°F	250.0°F
E Regen heater % on-time	.00 %	N/A
F Process heater % on-time	.00 %	N/A
G To process dew point	-28.4°F	-40.0 °F
T6 Drying monitor T6 temp.	70.2 °F	N/A
T5 Drying monitor T5 temp.	86.2 °F	N/A
T4 Drying monitor T4 temp.	55.1 °F	N/A
T3 Drying monitor T3 temp.	50.8 °F	N/A
T2 Drying monitor T2 temp.	154.3°F	N/A
T1 Drying monitor T1 temp.	92.8 °F	N/A

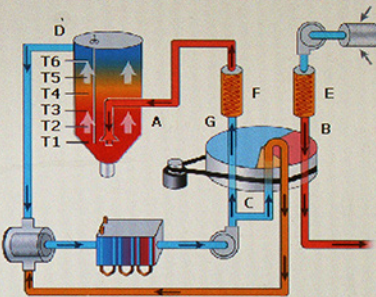

G: Dew point control

Set point: **-40.0°F**

Energy use

Energy	Last hour	Measure time
.0 kWh	.0 kWh	.0 Hours

D: Manual setback control

Set point: **250.0°F**

Setback to: **195.0°F**

Reset at: **150.0°F**

 **NOTE:** Shown with all options. Your screen may be different.

Dryer Settings Screen

This screen allows you to make changes to some of the dryer settings, and to navigate to the Dryer Setup Screens (if logged in at the appropriate security level). This screen will vary depending on the installed features.

Dewpoint control can be turned on/off and adjusted here. The Energy Meter can be turned on/off here and will display a value so that you can make changes to improve energy consumption.

This screen also allows for making adjustments to Setback Control settings. When enabled, the Setback Control will set the material drying temperature back to the “Setback to” value when the air temperature exiting the drying hopper reaches the Setpoint value for 5 minutes. When the air temperature exiting the drying hopper reaches the “Reset at” set point for 2 minutes, the material drying temperature returns to the original value.

In Manual mode, all set points are entered manually, based on your experiences. In Auto mode, the “Setback to” and “Reset at” values are calculated. Select the on/off push button to turn the control on or off. Select the M/A arrow button to switch between Manual and Auto modes.

When Dewpoint control is active, flashing text stating “Dewpoint Control Active” will appear to the right of the drying wheel in the graphic on this screen. When Clean Cycle is active, flashing text stating that “Clean Cycle Active” will appear to the right of the drying wheel in the graphic on this screen. Clean Cycle occurs after every 24 hours of accumulated run time. When Clean Cycle is active, you will notice that the regeneration temperature increases. This is normal. Refer to the Help screen for more information

Control Function Descriptions

Dryer settings screen help 6/28/2016 2:09:31 PM

PARAMETER	ACTUAL	SET POINT
A Material drying temperature	.0 °F	.0 °F
	.0 °F	.0 °F
	.0 °F	.0 °F
	00 %	N/A

The list of dryer settings is display only and will vary depending on the installed features.

When enabled, dew point control varies the regeneration temperature of the wheel to maintain the desired delivery air dew point. The range of the set point is -40 to 40F or -40 to 4.4C. Select the on/off push button to turn the control on or off.

When enabled, the energy meter displays the calculated energy use. The last hour value can be monitored to see if conditions have improved or worsened energy consumption. Select the on/off push button to turn the meter on or off/reset to zero.

When enabled, the set back control will set the material drying temperature back to the "Setback to" value when the air temperature exiting the drying hopper reaches the "Set point" value for 5 minutes.

When the air temperature exiting the drying hopper reaches the "Reset at" set point for 2 minutes, the material drying temperature returns to the original value. In manual all set points are entered manually. In auto the "Setback to" and Reset at" values are calculated. Select the on/off push button to turn the control on or off.

Select "X" to exit the help screen

This push button is visible when logged in as maint, super or admin. Select to access dryer set-up.

D: Manual setback control

Set point: °F

Setback to: °F

Reset at: °F

Manual Auto M A

Help Screen– Dryer Settings

This screen gives detailed information to help you adjust the settings on the Dryer Settings Screen.

Dryer set-up 6/28/2016 2:02:56 PM

31 Date and Time

Year: 2016

Month: 6

Day: 28

Hour: 14

Minute: 2

Second: 56

English Metric °F °C

Auto Start

Day: 1

Hour: 1

Minute: 1

Material drying temp. set point

Minimum: 150.0°F

Maximum: 350.0°F

Reset Password User password management

Current user: ADMIN Change Password

HMI ethernet

Close runtime

IP address: 10.1.11.6

Subnet: 255.255.255.0

Gateway: 10.1.11.1

PLC ethernet

IP address: 10.1.11.5

Subnet: 255.255.255.0

Gateway: 0.0.0.0

ADMIN

Dryer Set-up Screen

This screen may vary depending on the installed features. This screen allows for the Auto Start function to automatically start the dryer at a desired time. Enter the day of the month (1-31), the hour of the day (1-24), and the minutes of the hour (0-59) and turn on the function. After starting, the Auto Start automatically resets to off or disabled. The Material Drying Minimum and Maximum setpoints can also be set on this screen. The range set at the factory is 100°F to 375°F {37.7-190.5°C}. The Reset Password box is only visible when logged in as an Administrator. Select it to reset a user's password to a new password, when the old password is unknown. Select Change Password to change the password of the user currently logged in. The HMI and PLC Ethernet settings are display only information. Select the "Close Runtime" button only if you wish to exit the HMI operating system. Press the arrow button to navigate to the I/O test screen.

Control Function Descriptions

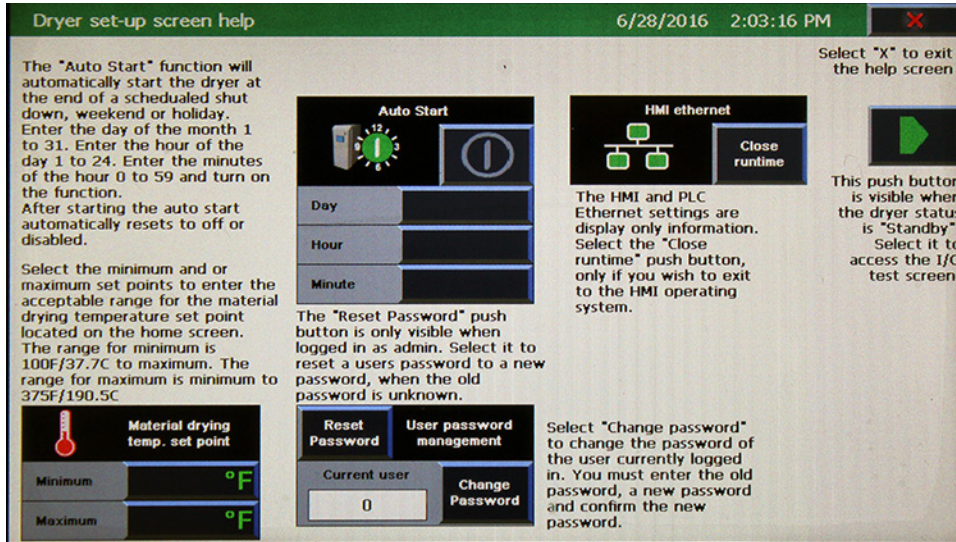

Help Screen – Dryer Set-up

This screen gives detailed information to help you adjust settings on the Dryer Setup Screen.

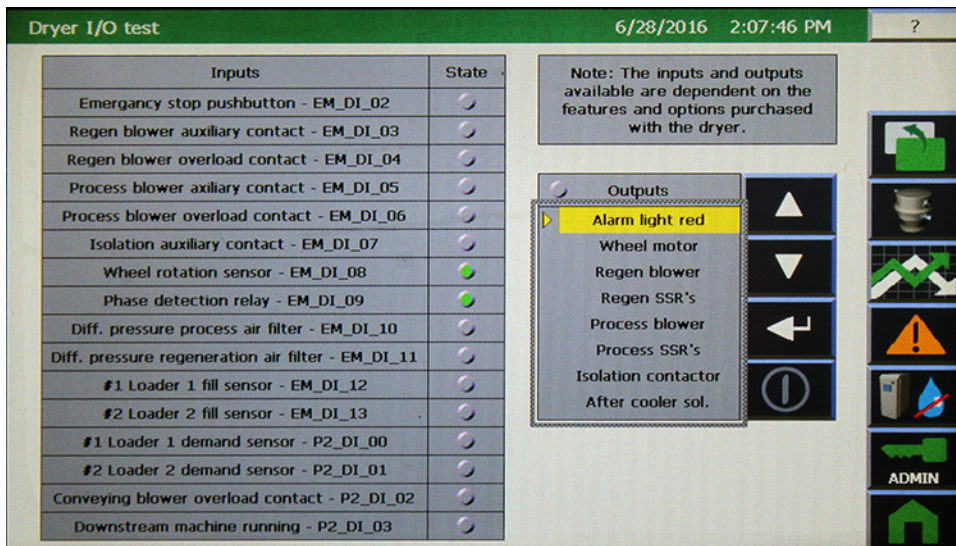

Dryer I/O Test Screen

This screen allows for testing of various outputs of your dryer. To turn on an output, use the up/down arrow buttons to move the yellow indicator to the output you wish to energize. Press the Enter button to select the output. Once selected, press and hold the On/Off push button to energize the output. Release the On/Off push button to turn the output off.

NOTE: After selecting an output with the up/down arrow, you must press enter to finish the selection prior to testing that output.

Control Function Descriptions

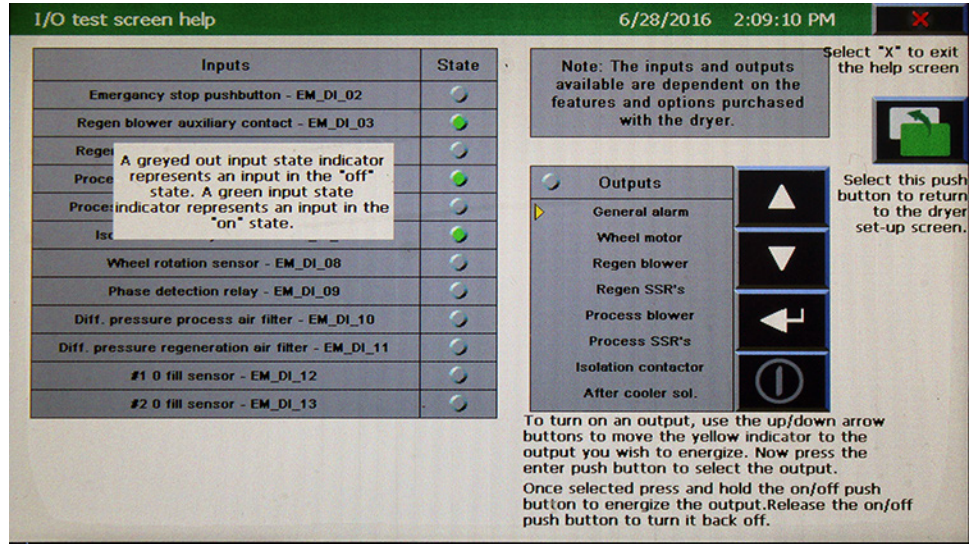

Help Screen – Dryer I/O Test

This screen provides detailed descriptions of how to use the Dryer I/O Test functionality of the control.

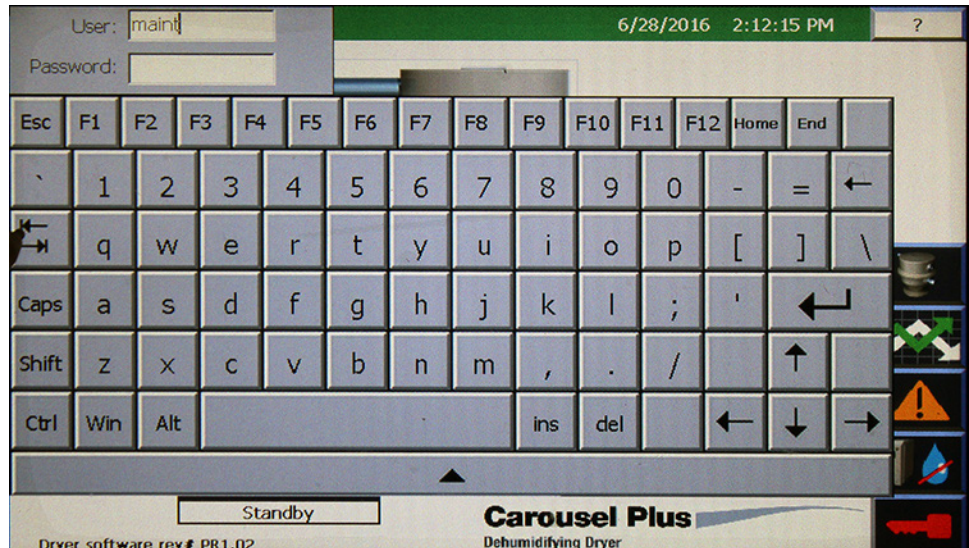

Security Login Pop-up

This page pops up after pressing the Security Key button to log in as a user. After logging in (see table below for login information), the Security Key button will display the current login level of the user.

Level	User	Password	Password Editable
1 (Low)	oper	oper	No
2	maint	maint	Yes
3	super	super	Yes
4 (High)	admin	admin	Yes + reset

To Start Drying

- 1 Make sure there is material in the hopper.
- 2 Turn on the main power to the dryer. Make sure the dryer's disconnect dial is in the ON position. This powers up the control.
- 3 Set the drying temperature. Press the Setpoint Temperature, then adjust the Setpoint. Enter the temperature on the numeric keypad and press enter.

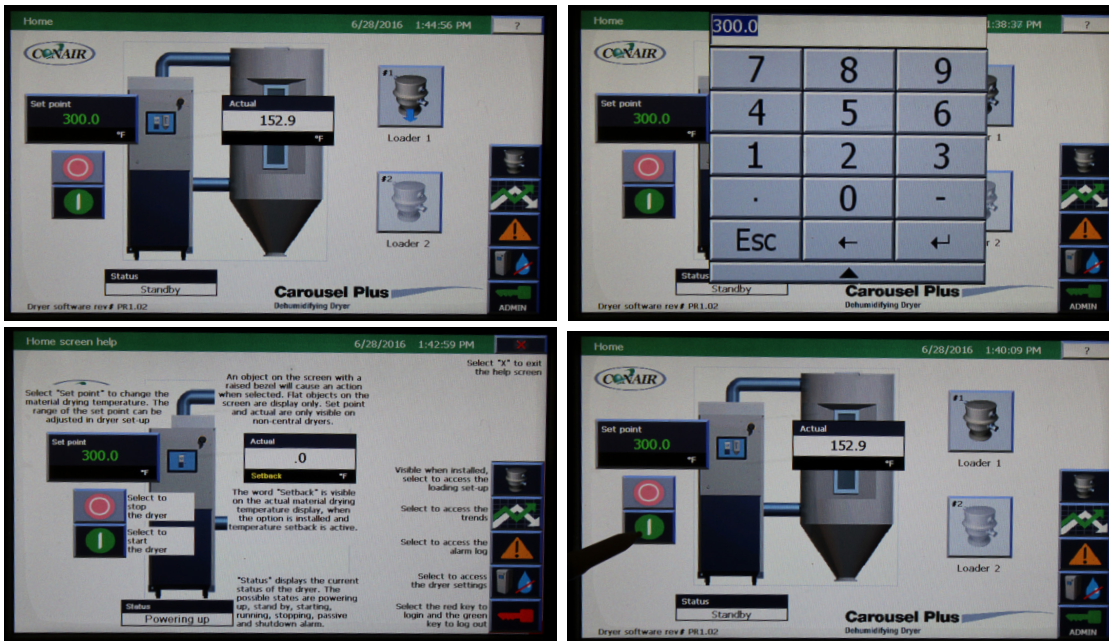
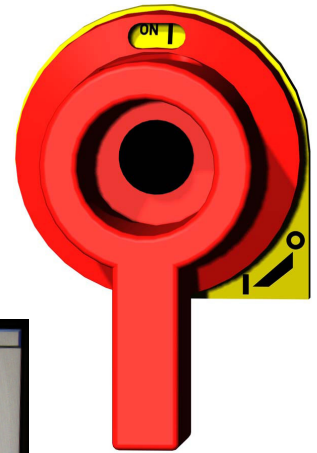

- 4 Press the **START** button.
If everything is installed correctly:

- The start button will fade.
- The process and regeneration blowers turn on.
- The process and regeneration heaters turn on.
- The status bar will display “Starting”.
- After the heaters turn on, the status bar will display “Running”.

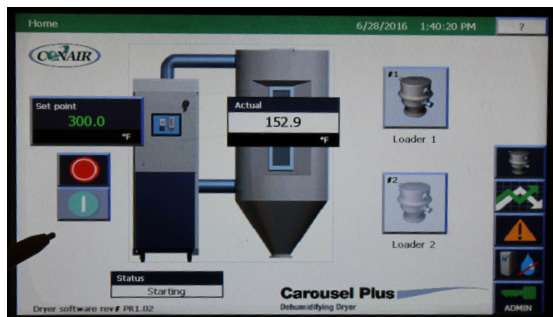

To Stop Drying



- 1 Press the STOP button.
 - The blowers continue running for a few minutes to cool the heaters.
 - The status bar will display “Stopping”.
- 2 Be sure to disconnect and lockout the main power if you have stopped the dryer to perform maintenance or repair.

IMPORTANT: Do not use the main power switch to stop the dryer. Turning off power to the control and dryer during normal operation prevents the necessary cool-down period, and can trigger the shutdown/high temperature alarm during your next drying cycle.



CAUTION:

Improper shut down can cause damage to your dryer.

Using the The Self-loading Function on the Hopper Loader (optional)

- 1 Connect the conveying hose and/or pick-up wand from the material source to the inlet on the hopper loader.
- 2 Connect a clean, dry compressed air source supplying 80 psi of compressed air to the threaded coupling on the side of the MDCW dryer.
- 3 Set the Loader settings.
- 4 Press the Loader button.
- 5 Set the load and discharge times.

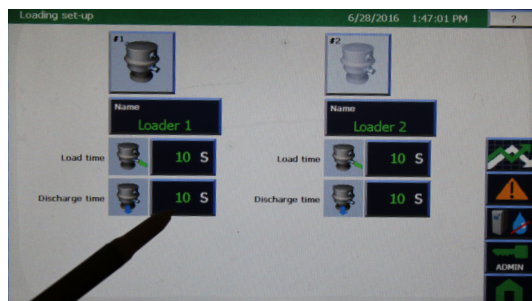
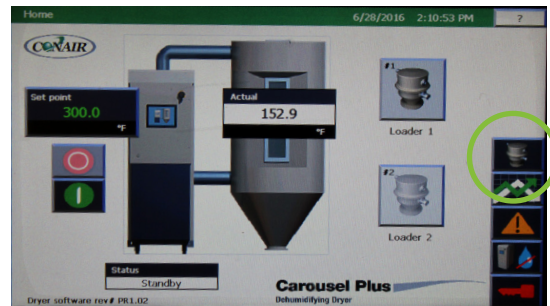

- 6 Adjust the hose connection on the pick-up wand to cover the number of holes to maximize the material flow.
- 7 Press the Loader icons on the home page and turn on loading for each Loader.

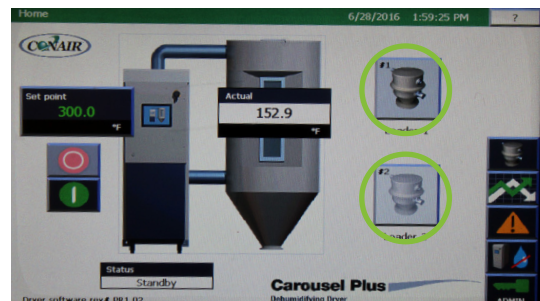

Machine Loader Conveying

- 1 Move the MDCW to the processing machine.** Lock the wheels and connect the main power source. Connect the water source if you have an aftercooler. Connect compressed air if the self-loading option is being used.
- 2 Mount the vacuum receiver on the feed throat.** Push the vacuum receiver onto the mounting bracket.



- 3 Place the appropriate material insert inside the distribution box.**
- 4 Make sure all hoses are connected securely.**
- 5 Adjust the demand sensor.** Position the sensor at the lowest level of material that you want to maintain in the viewing chamber before another load cycle begins. Make sure the sensor rests against the sight glass.
- 6 Set the load time.**
- 7 Start conveying.** Turn the “Loader” ON.

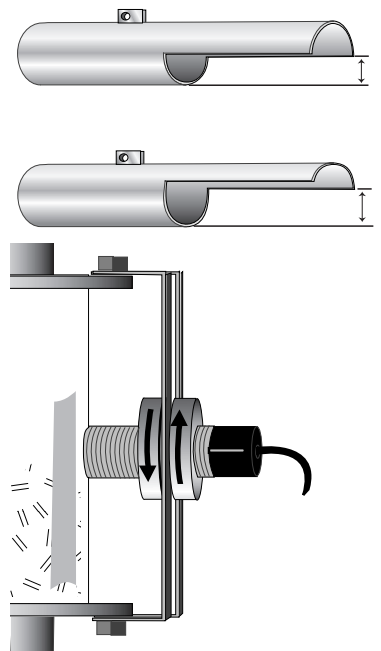



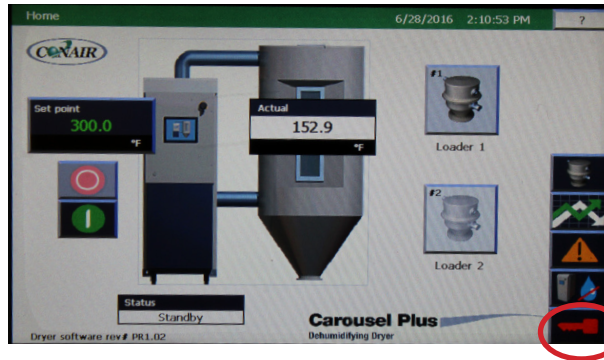

How to Log In

Level	User	Password	Password Editable
1 (Low)	oper	oper	No
2	maint	maint	Yes
3	super	super	Yes
4 (High)	admin	admin	Yes + reset



1 Select the Red key to login.

-  Highest permission
ADMIN
-  SUPER
-  MAINT
-  Lowest permission
OPER
-  No security enabled

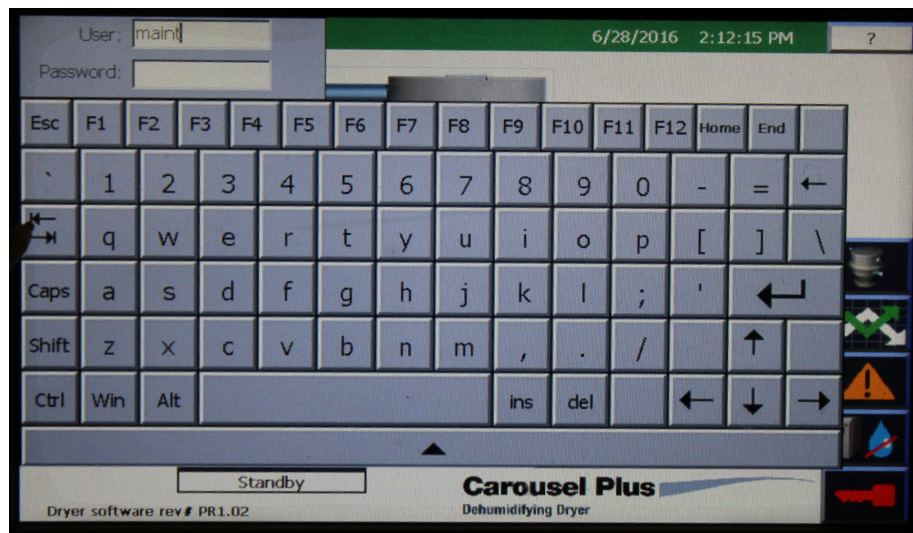

Using the Auto Timer

You can set the dryer to start automatically using the Auto Start function. The supervisor password is necessary to use this function.

Programming Auto Start

The Auto Start function can be programmed from the Dry setup screen. This screen can be accessed by pressing the Dryer Setup button from the home screen.

Once the Auto Start has been programmed dryer will automatically start at the set time.

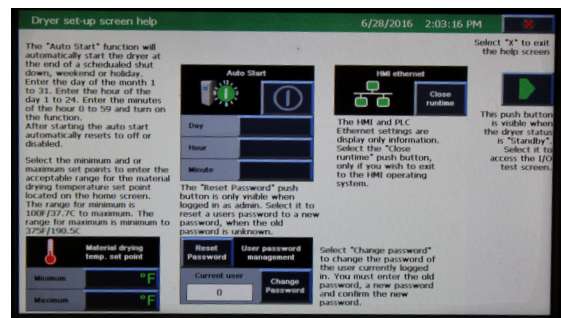
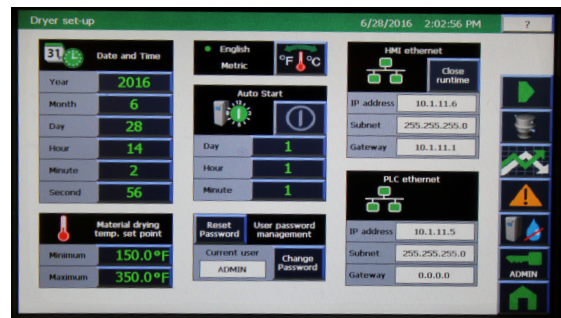

Setting High Setpoint Limits

You can protect your drying process by preventing someone from entering process temperatures above or below an acceptable level for the material. You can also set the high and low limits equal to the process temperature to prevent accidental or unauthorized changes to the setting during operation. Users must be logged in with the appropriate user level to change these settings.

- 1 Turn on the main power to the dryer.
- 2 Press the dryer setup button on the home screen.
- 3 Then set the minimum and maximum drying temperature setpoint.



NOTE: Conair is not responsible for damage caused by excessively high drying setpoints that are not in accordance with your drying material recommendations.

NOTE: Software may allow the process temperature setpoint limit up to 450°F {232°C}; however, Conair does not recommend a setpoint limit over 375°F due to nuisance alarms.

NOTE: To avoid nuisance alarms Conair recommends that the low setpoints be set to 150°F {66°C} or above.

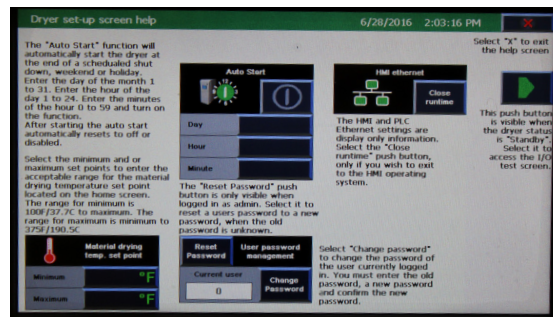
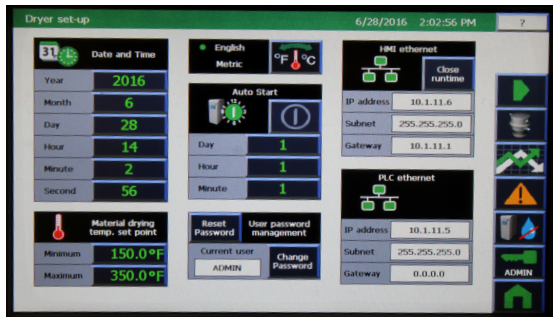

Using Dewpoint Control

Your dryer is equipped with a dewpoint monitor and dewpoint control features. You can choose to use it as a monitor only device, or to maintain a steady dewpoint that you select with the dewpoint control. Dewpoint control will vary the regeneration air temperature to condition the desiccant to the level necessary to maintain the desired dewpoint.

Dewpoint Control

NOTE: The supervisor's password is necessary.

- 1 From the home screen, select "Dryer Setup" to get to the "Dryer Setup screen".
- 2 Press the arrow navigation button on the dryer setup screen to view the Dryer Settings screen.
- 3 Turn Dew Point Control on or off by pressing the  button.
- 4 Adjust the Dew Point Control setpoint by pressing the text block.

NOTE: When Dewpoint Control is active, "Dewpoint Control Active" text will flash to the right of the drying wheel graphic on the Dryer Settings screen.

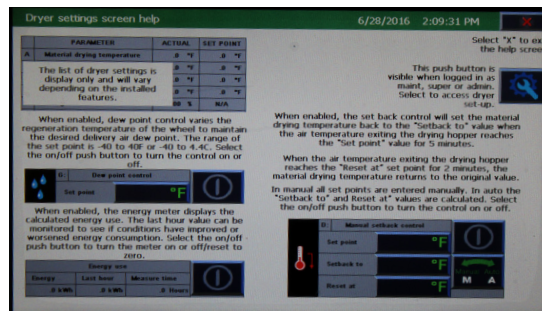
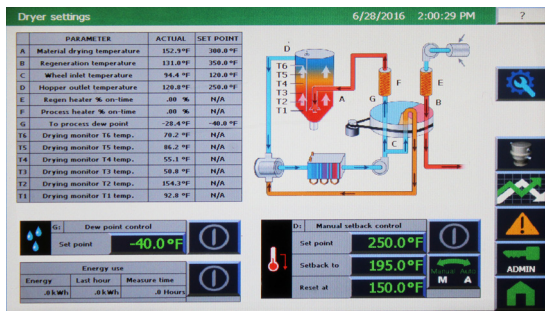

Using the Energy Use Monitor

- 1 From the home screen, select “Dryer Setup” to get to the “Dryer Setup Screen”.
- 2 Press the arrow navigation button to navigate to the Dryer Settings Screen.
- 3 Turn Energy Use monitoring on or off by pressing the  button.

Using the Setback Feature

The DC-A comes standard with setback installed, but disabled. You can choose to set the mode to “Off”, “Auto”, or “Manual”. Refer to the Control Function Descriptions later in this section for more detailed information.

This feature is designed to save you money on energy costs and help to keep you from over drying your material.

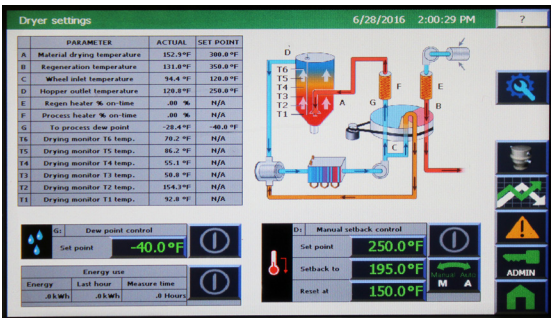

PARAMETER	ACTUAL	SET POINT
A Material drying temperature	152.3°F	300.0°F
B Regeneration temperature	131.0°F	300.0°F
C Wheel inlet temperature	184.0°F	120.0°F
D Hopper outlet temperature	120.0°F	250.0°F
E Regen heater % on-time	.00 %	N/A
F Process heater % on-time	.00 %	N/A
G To process dew point	-20.4°F	-40.0°F
H Drying monitor 16 temp.	78.2°F	N/A
I Drying monitor 15 temp.	86.2°F	N/A
J Drying monitor 14 temp.	55.1°F	N/A
K Drying monitor 13 temp.	50.0°F	N/A
L Drying monitor 12 temp.	154.3°F	N/A
M Drying monitor 11 temp.	52.0°F	N/A

This is how setback operates when the control setback mode is set on Temperature.

The control monitors the temperature of the air exiting the drying hopper. If that temperature reaches a customer-entered setpoint, the delivery process air temperature will automatically setback to a customer-entered setpoint. Then, if the air exiting the drying hopper drops below the customer-entered temperature an amount greater than what is desired, the process temperature will automatically reset back to the original value.

 **Note:** Make sure your setback temperature is approximately 40° F above your return air temperature when using this feature.

To Activate Setback:

- 1 From the home screen, select “Dryer Setup” to get to the “Dryer Setup Screen”.
- 2 Press the arrow navigation button to navigate to the Dryer Settings Screen.
- 3 Set the Setback settings. Set the setback process temperature. This is the setpoint at which the process temperature will go to once the control goes into setback. The actual temperature on the default screen will still show the actual temperature measured at the hopper inlet. The setpoint shown on the default screen will still show the original setpoint. The word “Setback” will appear on the Actual Temp.

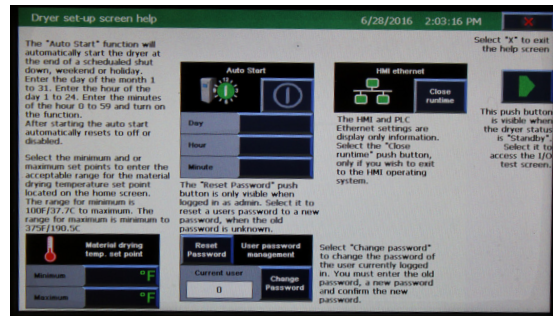

Auto Start
The “Auto Start” function will automatically start the dryer at the end of a scheduled shut down, weekend or holiday. Enter the day of the month 1 to 31. Enter the hour of the day 1 to 24. Enter the minutes of the hour 0 to 59 and turn on the function. After starting the auto start automatically resets to off or disabled. Select the minimum and/or maximum set points to enter the acceptable range for the material drying temperature set point located on the home screen. The range for minimum is 100F/37.7C to maximum. The range for maximum is minimum to 375F/190.5C.

HMI ethernet
The HMI and PLC Ethernet settings are display only information. Select the “Close runtime” push button, only if you wish to exit to the HMI operating system. This push button is visible when the dryer status is “Standby”. Select it to access the I/O test screen.

Material drying temp. set point
Minimum: 100.0°F
Maximum: 375.0°F

User password management
Reset Password: []
Current user: []
Change Password: []

Select “Change password” to change the password of the user currently logged in. You must enter the old password, a new password and confirm the new password.

Setback Feature Guidelines

Careful selection of setpoint values in these functions is necessary for the setback to operate properly. The following table is only a guideline of recommended settings for these setpoints. It will be necessary for each customer to determine the best setpoints for their application based on experience.

Normal Drying Temp	Setback Return Temp	Setback Temp (Process)
160° F {71° C}	120° F {49° C}	150° F {66° C}
240° F {116° C}	135° F {57° C}	180° F {82° C}
300° F {149° C}	160° F {71° C}	200° F {93° C}
340° F {171° C}	180° F {82° C}	220° F {104° C}

A recommended way to determine the “Setback” setpoint is to monitor the actual temperature of this function during pre-drying of your material at start-up, and while running at your normal maximum material throughput. The “Setback” setpoint should be set 10 to 20° above maximum temperature noted in these situations.

The “Setback” setpoint you select should be adequate to reduce the temperature significantly enough to prevent over-drying of your material. However, keep in mind that the cooler the temperature selected, the longer it will take for the material to heat back up to its proper drying temperature once the dryer comes out of Setback mode.

When drying at low temperatures (for example 160 - 180° F {71 - 82° C}), you are able to setback the temperature only a small amount. The “Setback Temperature (Process)” should not be set lower than 150° F {66° C}, even if the control will allow it. It is very likely the dryer will not be able to achieve low temperatures without adding additional cooling to the process air circuit. The maximum achievable setpoint is dependent on the temperature of the return air coming back to the dryer. As the return air temperature climbs, the temperature that the dryer is capable of controlling at climbs. For example, if the return air to the dryer is 110° F {43° C}, the dryer may not be able to control at a “Setback” setpoint below 150 - 155° F {66 - 68° C}.

 **NOTE:** Selecting too low of a setpoint may result in nuisance Process Temperature Loop Break alarms if the dryer is not able to achieve this setpoint.

Setback Auto vs Manual Mode

Typically, the Auto Setback mode will be used in most instances. The Manual Mode is available for operators who want to set specific ranges for Setback operation. In Auto mode, these temperatures are calculated by the dryer.

Automatic Cleaning Cycle

In order to maintain dryer efficiency, the DC-A Control initiates a Cleaning Cycle for the drying wheel after every 24 accumulated hours of run time. During this period, you will see “Clean Cycle Active” text flash to the right of the drying wheel graphic on the Dryer Settings screen.

During Clean Cycle operation, you will notice that the regeneration temperature increases, in order to properly clean the dryer and ensure optimal operation. This is normal. This Clean Cycle will not affect material drying, still allows changes to be made to the drying process, and will last anywhere from one hour to two hours, depending on your current drying temperature when the Clean Cycle initiates. If the dryer is stopped or turned off during the Cleaning Cycle, the Cleaning Cycle will stop and immediately resume with the dryer is re-started.

Maintenance

Preventative Maintenance Schedule	5-2
Checking the Dewpoint	5-3
Cleaning the Hopper	5-3
Clean the Process Filter	5-4
Cleaning the Regeneration Filters	5-4
Cleaning the Conveying Filter.....	5-5
Cleaning the Vacuum Receiver.....	5-5
Screen Filter Cleaning (optional)	5-6
Cleaning the Compressed Air Filter (optional)	5-7
Cleaning the Aftercooler Coils	5-7
Cleaning the Precooler Coils	5-8
Inspecting Hoses and Gaskets.....	5-8
Cleaning and Servicing the Desiccant Rotor	5-9

Preventative Maintenance Schedule

Routine maintenance will ensure optimum operation and performance of the MDCW Dryer and the receiver on the hopper. We recommend the following maintenance schedule and tasks.

- **Whenever you change materials**
 - Drain and clean the hopper.**
 - **Weekly or as often as necessary**
 - Clean or replace the process, regeneration and conveying filters.**
You may need to clean filters more often than weekly. Frequency depends on how much material you process and how dusty or full of fines it is.
 - Inspect hoses and hose connections.**
Check for damage, kinks, or loose hose clamps. Replace any hoses that show signs of damage or wear. Reposition and tighten loose hose clamps.
 - Clean and check the filter for clogging or holes.***
Replace if necessary.
 - Drain the compressed air filter trap (if equipped).***
Depending on your compressed air system, you may see moisture or oil in the compressed air filter trap. Open the petcock on the bottom of the trap to drain.
 - **Monthly, or as often as necessary**
 - Clean the aftercooler and/or optional precooler coils.**
You may need to clean the coils more often than monthly. Frequency will depend on the type and volume of material you process.
-  **NOTE:** Signs of contamination may indicate need for volatile trap. Contact Conair Parts for assistance.
- Check the seals of the vacuum sequencing valve, optional ratio valve and discharge valve pan***
- **Every six months or as often as necessary**
 - Inspect gaskets for damage or wear.**
Damaged gaskets can allow moisture to seep into the closed-loop drying system. Replace any gasket that is torn or cracked.
 - Verify dewpoint readout and performance with calibrated portable instrument.**
 - Measure current draw on all 3 legs of heater wires.**
This is to ensure that the heater is working properly.
 - Examine the bolts.**
Examine the bolts or clips holding the loader to the surface. Make sure the bolts or clips are tight.*
 - Inspect Dessicant Rotor and Return Air Ducting for signs of contamination.**
Clean or replace Dessicant Rotor if there are any signs of contamination. Consider adding a Volatile Trap.

* Procedures marked with an asterisk are steps to follow for the receiver located on top of the hopper.

Checking the Dewpoint

It is a good idea to monitor the dewpoint performance of your dryer periodically with a calibrated portable dewpoint monitor, to ensure it is performing at maximum capacity. Even if your dryer has a dewpoint readout, comparing it to a portable instrument periodically will confirm that the dewpoint sensor and readout is performing properly.

To check dewpoint on models MDCW 15-100:

- 1 Connect your portable dewpoint meter to the dewpoint check port of the dryer.**
- 2 Turn on the portable instrument**, and ensure there is positive airflow through the sensor.
- 3 Monitor the readout** and allow ample time for it to stabilize before disconnecting it. Some dewpoint monitors require a substantial amount of time for residual moisture to be purged from the sensor.
- 4 In the event the dewpoint is not satisfactory**, *refer to the Troubleshooting section of the manual* under Process Dewpoint alarm.

 **NOTE:** Portable dewpoint monitors purchased from Conair were provided with a male connector that plugs into the dewpoint check port. If you purchased your portable instrument elsewhere, the male connector is available through the Conair parts department.

 **NOTE:** The dewpoint check port was not included on early dryers. It can be added easily. Contact the Conair parts department or follow the alternate procedure.

Cleaning the Hopper



CAUTION: Hot Surfaces

Always protect yourself from hot surfaces inside the dryer and hopper.

The hopper, spreader cone, and discharge assembly should be cleaned thoroughly between material changes to prevent resin contamination.

- 1 Close the hopper slide gate.**
- 2 Disconnect the hoses and remove the distribution box** under the hopper and drain the remaining material into a bucket.
- 3 Remove the spreader cone.** Open the hopper door. Reach into the hopper. Grasp the spreader cone tube, lift up slightly, twist and then push down to release it. Tilt the cone assembly and pull it out through the hopper door.
- 4 Clean the spreader cone and the inside of the hopper.** Make sure you also clean the return air screen at the return air outlet of the hopper.
- 5 Repeat the steps in reverse order to reassemble the hopper** before adding material.



Clean the Process Filter

Clogged filters reduce air flow and dryer efficiency. Cleaning frequency depends on how much material you process and how dusty or full of fines it is.



CAUTION: Hot Surfaces

Always protect yourself from hot surfaces inside and outside the dryer and drying hopper.

- 1 To access the filter push down and turn the top of the filter housing in a clockwise direction to remove.
- 2 Remove the filter cartridge from the filter housing.
- 3 Clean or replace the filter.
- 4 Wipe the inside of the filter housing clean, then replace the filter cartridge into the housing.
- 5 Line up the slots in the top of the filter housing, push down and turn counterclockwise until locked into place.



CAUTION: Wear eye protection.

If you use compressed air to clean the equipment, you must wear eye protection and observe all OSHA and other safety regulations pertaining to the use of compressed air.

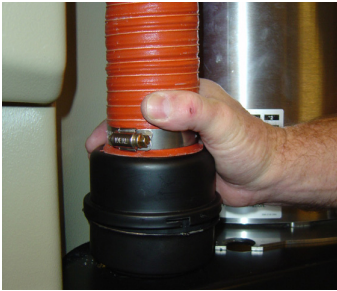

Cleaning the Regeneration Filters

Clogged filters reduce air flow and dryer efficiency. Cleaning frequency depends on how much material you process and how dusty or full of fines it is.



CAUTION: Hot Surfaces

Always protect yourself from hot surfaces inside and outside the dryer and drying hopper.

- 1 To access the regeneration filter, use a small flat screwdriver to gently pry down on the slot in the lower right hand corner of the filter grill while pulling out on the bottom.
- 2 Remove the filter from inside the grill and clean with soap and water.
- 3 Replace the filter in the grill and snap the grill into place.



NOTE: The control cabinet must be securely closed while the dryer is in operation to ensure that regeneration air is filtered.

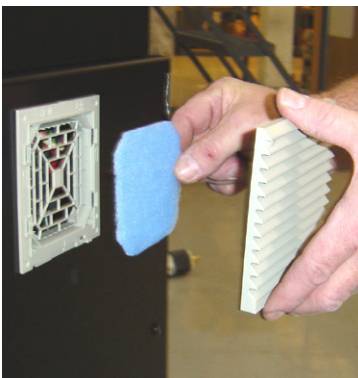
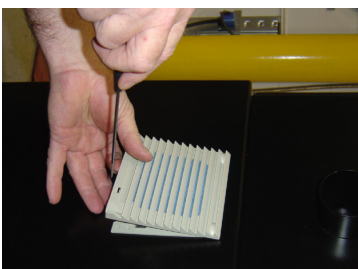

Cleaning the Conveying Filter

The conveying filter captures dust and fines from the air used to convey material. The filter should be cleaned regularly to maintain conveying airflow and optimum performance of the conveying blower.

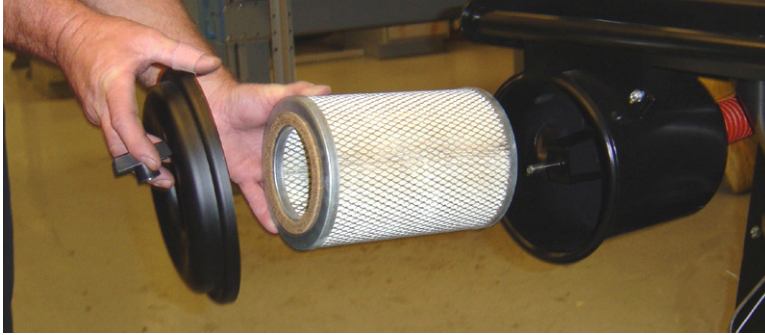

- 1** Turn off the conveying function. There is a conveying on/off switch located on the front of the dryer.
- 2** Remove the filter housing cover.
- 3** Remove the filter cartridge, clean or replace as necessary.
- 4** Replace the filter cartridge and the filter housing cover.

Cleaning the Vacuum Receiver

The vacuum receiver should be cleaned anytime you change materials. Replace the screen mesh filter if it is torn, damaged, distorted or so clogged with material that it cannot be cleaned.

- 1** Turn off switch to stop conveying. Disconnect the air and material hoses from the vacuum receiver.
- 2** Open the vacuum receiver lid. Turn the latch counterclockwise and flip the lid open.
- 3** Remove and clean the mesh filter. Lift the mesh filter out of the vacuum receiver. Clean or replace as necessary.
- 4** Loosen the 3 thumbscrews, slide the clips aside, and lift the vacuum receiver body from the viewing chamber. Clean inside the vacuum receiver body with a clean rag.
- 5** Remove and clean the viewing chamber. Lift the viewing chamber to release it from the mounting bracket. Clean inside with a clean rag.
- 6** Reassemble the vacuum receiver. Make sure the viewing chamber and loader body seat snugly inside the O-ring couplings.

 **NOTE:** The receiver on the hopper must also be cleaned with self-loading option, [see Screen Filter Cleaning](#).



CAUTION: Wear eye protection.

If you use compressed air to clean the equipment, you must wear eye protection and observe all OSHA and other safety regulations pertaining to the use of compressed air.



CAUTION: Wear eye protection.

If you use compressed air to clean the equipment, you must wear eye protection and observe all OSHA and other safety regulations pertaining to the use of compressed air.

Screen Filter Cleaning (optional)



DANGER: Electrical and air hazard



Always disconnect the main power source and compressed air source before removing the filter. This prevents the loader from starting during servicing, which could cause injury from flying debris or moving parts.



CAUTION: Wear eye protection

We recommend that you use vacuum air for cleaning filters and other parts of this equipment. If you use compressed air to clean the equipment, you must wear eye protection and observe all OSHA and other safety regulations pertaining to the use of compressed air.



The screen filter of your TLR is typically cleaned when materials are changed and in the event of conveying problems.

- 1 Turn off power.** Turn off the TLR loader or disconnect the control connection cable from the UTB.
- 2 Remove the filter.** Open the lid of the TLR by releasing the swing clamp that secures the lid. Once the lid is opened, the screen filter is easily visible, installed in the top of the tube loader body and may be lifted out for inspection or cleaning.
- 3 Inspect the filter carefully.** Check for holes that could allow the passage of pellets or regrind. Replace the filter if it is damaged, excessively worn or too clogged with fines and dust to be cleaned. Be sure to discard and replace any filter that has become hopelessly clogged with material dust. Do not attempt to repair a damaged filter.
- 4 Clean the filter.** A simple wipe down with a clean cloth or vacuuming will typically remove most material dust and fines. Slight tapping of the filter on a hard surface will loosen more embedded fines, but hard banging could distort or ruin the filter media and should be avoided.
- 5 Replace the filter.** Replace the filter onto the loader. Firmly press down on the filter to make sure there is a good seal around the entire perimeter of the filter module.



NOTE: The filter in your Conair TLR Tube Loader performs double-duty as an effective seal between the hopper body and the lid of the loader, so be sure to examine the integrity of the rubber seal at the top to ensure that the lid will seal effectively when reclamped. Replace the entire filter if the rubber seal is damaged or excessively worn.

Cleaning the Compressed Air Filter (optional)

You can add a moisture trap to the compressed air supply of your loader. A moisture trap can prevent troublesome moisture, contained in the air, from entering the loader.

The filter bowl of this moisture trap must be emptied regularly to drain the water from the air system. Follow the instructions listed on the filter bowl itself, which usually requires opening a port at the base of the bowl and letting the water in the bowl blow out in a stream of compressed air. Creating a path for this blowout of moisture is usually a good idea, to prevent a stream of moisture-soaked air from contaminating machines or people.

It is also a good idea to inspect the bowl periodically with the compressed air supply turned off, to clean or replace the filter element if need be or to remove contaminant accumulation, if it is present.



Cleaning the Aftercooler Coils

You need to clean the aftercooler coils to keep them working efficiently. Cleaning frequency depends on the type and amount of material you process.



CAUTION: Hot Surfaces

Always protect yourself from hot surfaces inside and outside the dryer and drying hopper.

- 1 Stop the dryer and lockout the main power.**
- 2 Turn off the water flow to the water supply line.** Disconnect supply and return lines.
 **NOTE:** If an optional flow control was added with the aftercooler, remove the compression fitting from the aftercooler inlet. Loosen the fitting on the flow control, then swing the copper water supply tube out and away from the aftercooler inlet.
- 3 Remove the two (2) nuts securing the aftercooler in the housing.**
 **TIP:** If the aftercooler (without a flow control) was installed using the recommended 24 inches {61 cm} of flexible hoses, there is no need to disconnect the hoses from the aftercooler inlet and outlet.
- 4 Remove the aftercooler assembly from the aftercooler housing.**
- 5 Clean the assembly using a mild soap and water.** Let the assembly dry thoroughly before installation.
- 6 Inspect the condition of the gasket.** If it is damaged, replace the gasket.
- 7 Reassemble by repeating the steps in reverse order.**
- 8 Connect the water supply line to the inlet.** If a manual shut off valve is used, it should be mounted on the inlet line as well.
- 9 Connect the outlet of the aftercooler to the inlet of the flow control valve** using the pre-shaped copper tubing and compression fittings provided.



Cleaning the Precooler Coils

If you have the optional precooler, you need to clean the cooling coils to keep them working efficiently. See Appendix B for details.



CAUTION: Hot Surfaces

Always protect yourself from hot surfaces inside and outside the dryer and drying hopper.

Inspecting Hoses and Gaskets

Loose or damaged hoses and gaskets can allow moisture to seep into the closed-loop drying system.



CAUTION: Hot Surfaces

Always protect yourself from hot surfaces inside and outside the dryer and drying hopper.

- 1 Follow the hose routing of all the hoses within the dryer and inspect all hoses, clamps, fittings, and gaskets.**
- 2 Tighten any loose hose clamps or fittings.**
- 3 Replace worn or damaged hoses and gaskets.**

Cleaning and Servicing the Desiccant Rotor

Visually inspect the wheel for blockage from dirt. Use drop light or strong flashlight on one side of wheel. Light should be visible on other side of wheel. If more than 15% blockage exists, wheel should be cleaned.

- 1 Use a wet vac with soft brush nozzle to vacuum both wheel faces.**
- 2 Re-inspect**, if blockage still exists, use maximum 30 psig dry compressed air, no closer than 12” from wheel face to blow dirt from wheel. Combine vacuum for added assistance.
- 3 If blockage still exist no further field cleaning is possible.** Wash and Re-impregnate.
- 4 The desiccant wheel should be dried out soon after the washing process** to minimize the stresses placed on the wheel structure by the substantial water weight increase.
- 5 The wheel may be dried by returning it to the dehumidifier.**
- 6 Run the unit in this manner until the reactivation outlet temperature reaches 120°F minimum.** Then run an additional 10 minutes.

For information on replacing the Desiccant Rotor, *see Chapter 6, Replacing the Desiccant Wheel Assembly.*

Troubleshooting



Before Beginning	6-2
A Few Words of Caution.....	6-3
Identifying the Cause of a Problem	6-3
Shutdown Alarms	6-4
Passive Alarms	6-8
Poor Material Drying Troubleshooting	6-15
Replacing Fuses.....	6-20
Checking or Replacing Temperature Sensors.....	6-20
Replacing the Heaters.....	6-22
Replacing the Desiccant Wheel Assembly	6-24

Before Beginning

You can avoid most problems by following the recommended installation, operation and maintenance procedures outlined in this User Guide. If you have a problem, this section will help you determine the cause and tell you how to fix it.

Before you begin troubleshooting:

Diagnose causes from the control panel.

- 1 Press  once to silence the optional audible alarm and display the alarm message.
- 2 Address the alarm message and fix the problem. (Refer to the alarm descriptions later in this section.)
- 3 Press  again to clear the alarm. If the alarm reappears the problem was not fixed.

 **NOTE:** Use of I/O test screens may assist with the determining of possible cause of an alarm..

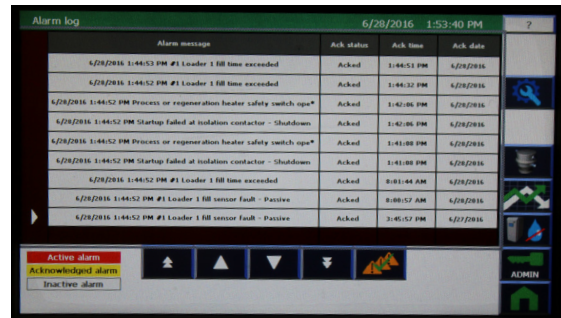
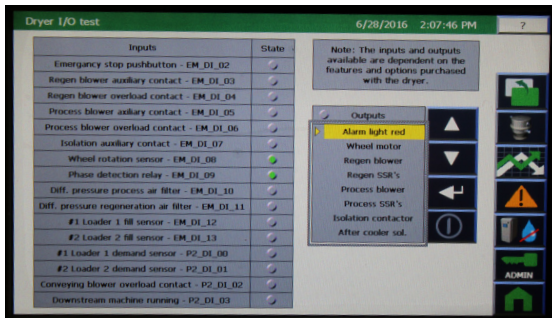

- Find any wiring, parts, and assembly diagrams that were shipped with your equipment.** These are the best reference for correcting a problem. The diagrams will note any custom features or options not covered in this User Guide.
- Verify that you have all instructional materials related to the MDCW.** Additional details about troubleshooting and repairing specific components are found in these materials.
- Check that you have manual for other equipment connected in the system.** Troubleshooting may require investigating other equipment attached to, or connected with the MDCW.

Additional manuals and prints for your Conair equipment may be ordered through the Customer Service or Parts Department for a nominal fee. Most manuals can be downloaded free of charge from the product section of the Conair website. www.conairgroup.com

Contact Conair
Parts and Service
Phone: 800-458-1960
From outside of the
United States,
Call: 814 437 6861



A Few Words of Caution

The MDCW Carousel Plus W Series dryer is equipped with numerous safety devices. Do not remove or disable them. Improper corrective action can lead to hazardous conditions and should never be attempted to sustain production.



WARNING: Improper installation, operation or servicing may result in equipment damage or personal injury.

This equipment should only be installed, adjusted, and serviced by qualified technical personnel who are familiar with the construction, operation, and potential hazards of this type of machine.

All wiring, disconnects, and fuses should be installed and adjusted by qualified electrical technicians in accordance with electrical codes in your region. Always maintain a safe ground. Do not operate the equipment at power levels other than what is specified on the machine serial tag and data plate.



WARNING: Voltage hazard



Always stop the Carousel Plus dryer, disconnect and lock out the main power source before troubleshooting or performing repairs.



CAUTION: Hot Surfaces

Always protect yourself from hot surfaces inside and outside the dryer and hopper.

Identifying the Cause of a Problem

Most dryer alarms are indicated by an Alarm Banner at the top of the screen. Shutdown alarms will sound a horn and turn on the alarm beacon.

A problem can trigger two types of alarms:

- **Shutdown:** The dryer has automatically shut down because it detected a serious problem that could damage your material or dryer.
- **Passive:** The dryer continues to operate, but warns of a problem that could prevent correct drying of your material. If ignored, this problem could lead to a condition that will shut down the dryer.

When the alarm banner is displayed:

- 1 Press the Alarm banner to display the alarm message.
- 2 Find the error message in the diagnostics table of this Troubleshooting section. Use information provided to diagnose and resolve the cause of the alarms.



NOTE: Pressing the  button a second time will clear the alarm once the cause has been corrected. If the alarm reappears, the cause has not been resolved.



NOTE: Pushing the Alarm button when there is no active alarm will take the user directly to the Alarm History list.



NOTE: The dryer cannot be started if a shut down alarm is present on power-up.



NOTE: When the dryer detects abnormally high temperature in the process heater, the dryer immediately shuts down and an error message appears in the display window.

Shutdown Alarms

If the Alarm Banner is red the alarm is a shutdown alarm. The dryer will shutdown automatically to prevent damage to the equipment or personnel.

Contact Conair
Parts and Service
Phone:
800-458-1960
From outside of the
United States,
Call: 814 437 6861

Symptom	Possible Cause	Solution
E-stop pressed E-stop pressed	E-stop pressed.	Resolve any issues, reset E-stop. Ensure dryer was shutdown properly instead of using E-stop. This is intended for emergency use only.
Process or regeneration heater safety switch open The snap switch in the process/regeneration heater tube opens due to excessive temperature.	Loose wire to coil of isolation contactor.	Verify control wire connection to isolation contactor,
	Temperature switch is open.	Check continuity of heater snap switch.
	Defective coil on isolation contactor.	Verify control wire connection to isolation contactor.
	Process blower not running or out of phase.	Verify blower rotation and operating.
	Process blower not running.	Verify process blower is operating.
Process temperature control fault The process temperature is not moving towards the setpoint at a rate greater than specified.  NOTE: 15 degree band from setpoint for 10 seconds.	Loose or missing hose, blockage.	Check for loose, blocked, or missing hose.
	Process RTD is loose or has fallen out.	Check process RTD and tighten if needed.
	Process heater has failed, air line is restricted.	Check heater fuses & resistance across each leg of process heater.
	Process blower is not running or is running in wrong direction.	Fix any crimps in hoses, and correct cause for non-running blower or reverse rotation.
	Solid state relay has failed on.	Check heater fuses & resistance across each leg of process heater.

Shutdown Alarms (continued)

If the Alarm Banner is red the alarm is a shutdown alarm. The dryer will shutdown automatically to prevent damage to the equipment or personnel.

Symptom	Possible Cause	Solution
<p>Regeneration heater safety switch open The snap switch in the regeneration heater tube opens due to excessive temperature.</p> <p> NOTE: Only for central dryer configuration</p>	<p>Loose wire to coil of isolation contactor.</p> <p>Temperature switch is open.</p> <p>Defective coil on isolation contactor.</p> <p>Process blower not running or out of phase.</p> <p>Regeneration blower not running.</p> <p>Loose or missing hose, blockage.</p>	<p>Verify control wire connection to isolation contactor.</p> <p>Check continuity of heater snap switch.</p> <p>Verify control wire connection to isolation contactor.</p> <p>Verify blower rotation.</p> <p>Verify regeneration blower is operating.</p> <p>Check for loose or missing hose.</p>
<p>Regeneration temperature control fault The regeneration temperature is not moving towards the setpoint at a rate greater than specified.</p>	<p>Regeneration RTD is loose or has fallen out.</p> <p>Regeneration heater has failed.</p> <p>Air line is restricted.</p> <p>Regeneration blower is not running or is running in wrong direction.</p> <p>Solid state relay has failed on.</p>	<p>Check regeneration RTD and tighten if needed.</p> <p>Check heater fuses & resistance across each leg of regeneration heater.</p> <p>Fix any crimps in hoses.</p> <p>Fix any crimps in hoses, and correct cause for non-running blower or reverse rotation.</p> <p>Check heater fuses & resistance across each leg of regeneration heater.</p>

Shutdown Alarms (continued)

If the Alarm Banner is red the alarm is a shutdown alarm. The dryer will shutdown automatically to prevent damage to the equipment or personnel.

Symptom	Possible Cause	Solution
Regeneration RTD fault The regeneration RTD is loose or plug-in I/O module is loose/faulty.	The regeneration RTD connection to the plug-in I/O module is loose.	Verify connection to the I/O module and check RTD plug connection.
	The regeneration RTD has failed.	Check RTD plug connection and replace RTD if faulty.
	The I/O module has failed.	Replace plug-in I/O module.
Regen blower overload If the regeneration blower exceeds its full load amp rating or the overload has tripped due to a mechanical or electrical problem.  NOTE: W150 & larger only.	The regeneration blower current draw has exceeded the FLA rating of the motor.	Manually reset the overload.
	The regeneration blower has mechanically failed or is unable to rotate freely.	Check regeneration blower for mechanical failure and free rotation.
	The regeneration blower has failed electrically.	Check regeneration blower for electrical short or open circuits.
Desiccant wheel not rotating The desiccant wheel is not turning.	The desiccant motor or motor coupling has failed.	Verify desiccant motor or motor coupling has not failed.
	The gap setting of the proximity switch is incorrect.	Verify gap setting of proximity switch.
Startup failed at process blower Process blower did not start	Process blower starter did not turn on.	Check connections to coil of starter, check connection to auxiliary contact of starter.
Startup failed at regen blower Regeneration blower did not start.	Regeneration blower starter did not turn on.	Check connections to relay.
Startup failed at isolation contactor Isolation contactor failed to come on.	Isolation contactor failed to come on.	Check control connections to isolation contactor, and verify heater high temperature switches are closed.

(Continued)

Shutdown Alarms (continued)

If the Alarm Banner is red the alarm is a shutdown alarm. The dryer will shutdown automatically to prevent damage to the equipment or personnel.

Symptom	Possible Cause	Solution
Startup failed at SSRs Temperature control loop did not come on.	Corrupt PLC program.	Restore program from Eprom.

Passive Alarms

If the Acknowledge Alarm light is blinking, the alarm is a passive alarm. The dryer continues to operate, but this problem could prevent correct drying of your material.

Symptom	Possible Cause	Solution
Dewpoint high The dewpoint has not fallen below the setpoint.	Defective DP sensor.	Replace DP sensor.
	Hose or wiring connector to the sensor block are loose or fallen off.	Check hose and wiring connections to sensor block.
	Poor regeneration air flow.	Remove air flow restrictions or replace dirty filters.
	The desiccant wheel may be contaminated.	Check desiccant for contamination and replace if need; install volatile trap if necessary.
	Leaks in the process air stream.	Check for worn or loose hoses.
Clean or replace process filter The process filter differential pressure switch is tripped.	Desiccant wheel not rotating.	Check drive motor and motor coupling for failure.
	Return air temperature too high.	Verify water flow to after cooler.
	The process filter is clogged.	Remove and clean or replace process air filter.

Passive Alarms (continued)

If the Acknowledge Alarm light is blinking, the alarm is a passive alarm. The dryer continues to operate, but this problem could prevent correct drying of your material.

Symptom	Possible Cause	Solution
Return air RTD fault The return air RTD is loose or plug-in I/O module is loose/faulty.	The return air RTD connection to the plug-in I/O module is loose.	Verify connection to the I/O module, and check RTD plug connection.
	The return air RTD has failed.	Replace RTD.
	The I/O module has failed.	Replace plug-in I/O module.
Hopper outlet RTD fault The temperature setback RTD is loose or plug-in I/O module is loose/faulty.	The temp setback air RTD connection to the plug-in I/O module is loose.	Verify connection to the I/O module, and check RTD plug connection.
	The temp setback air RTD has failed.	Replace RTD.
	The I/O module has failed.	Replace plug-in I/O module.
Conveying/pump overload If the conveying blower exceeds its full load amp rating or the overload has tripped due to a mechanical or electrical problem.	The conveying blower current draw has exceeded the FLA rating of the motor.	Manually reset the overload.
	The conveying blower has mechanically failed or is unable to rotate freely.	Check conveying blower for mechanical failure and free rotation.
	the conveying blower has failed electrically.	Check conveying blower for electrical short or open circuits.
Drying monitor low temperature Active Drying Monitor RTD is below setpoint.	Low process airflow.	Clean or replace process air filter.
	Low process temperature.	Verify operation of process heater.
	Throughput exceeded.	Verify actual throughput vs. dryer sizing.
	No material in hopper or conveying issues.	Verify conveying system working properly.

Passive Alarms (continued)

If the Acknowledge Alarm light is blinking, the alarm is a passive alarm. The dryer continues to operate, but this problem could prevent correct drying of your material.

Symptom	Possible Cause	Solution
Drying monitor high temperature Active Drying Monitor RTD is above setpoint.	Material throughput is too low.	Ensure the material usage is within the rated capacity of the dryer/hopper.
	Material level in hopper is above the selected high temperature alarm RTD.	Check material supply system for problems.
	Process air is not at the proper temperature.	Reduce the process air temperature.
	Too much air flow to the hopper.	Reduce air flow.
Drying monitor T1 RTD fault RTD has failed or DM cable connection is loose.	The RTD has failed.	Replace DM probe.
	DM cable connection is loose.	Check DM cable connection.
	Connection to I/O module is loose.	Check DM cable connection.
Drying monitor T2 RTD fault RTD has failed or DM cable connection is loose.	The RTD has failed.	Replace DM probe.
	DM cable connection is loose.	Check DM cable connection.
	Connection to I/O module is loose.	Check DM cable connection.
Drying monitor T3 RTD fault RTD has failed or DM cable connection is loose.	The RTD has failed.	Replace DM probe.
	DM cable connection is loose.	Check DM cable connection.
	Connection to I/O module is loose.	Check DM cable connection.

Passive Alarms (continued)

If the Acknowledge Alarm light is blinking, the alarm is a passive alarm. The dryer continues to operate, but this problem could prevent correct drying of your material.

Symptom	Possible Cause	Solution
Drying monitor T4 RTD fault RTD has failed or DM cable connection is loose.	The RTD has failed.	Replace DM probe.
	DM cable connection is loose.	Check DM cable connection.
	Connection to I/O module is loose.	Check DM cable connection.
Drying monitor T5 RTD fault RTD has failed or DM cable connection is loose.	The RTD has failed.	Replace DM probe.
	DM cable connection is loose.	Check DM cable connection.
	Connection to I/O module is loose.	Check DM cable connection.
Drying monitor T6 RTD fault RTD has failed or DM cable connection is loose.	The RTD has failed.	Replace DM probe.
	DM cable connection is loose.	Check DM cable connection.
	Connection to I/O module is loose.	Check DM cable connection.

Passive Alarms

Hopper Loader

If the Acknowledge Alarm light is blinking, the alarm is a passive alarm. The dryer continues to operate, but this problem could prevent correct drying of your material.

Symptom	Possible Cause	Solution
<p>#1 Resin loading fault “loader name” The demand sensor located at the hopper receiver has not been satisfied.</p>	The sensor is not adjusted properly.	Adjust sensor.
	No material is being conveyed.	Check material supply.
	Conveying load time is too short.	Increase load time
	Conveying blower is not operating.	Check conveying blower fuses and overload settings.
	The conveying filter is clogged.	Clean or replace conveying filter.
	Hoses have come off or are loose.	Check for loose hoses.
	The air valves are not opening.	Make sure compressed air is connected and that solenoid valves are operating properly.
<p>#1 “loader name” fill sensor fault The demand sensor located at the receiver has failed.</p>	The sensor is not adjusted properly.	Adjust sensor.
	No material is being conveyed.	Check material supply.
	Conveying load time is too short.	Increase load time.
	Conveying blower is not operating.	Check conveying blower fuses and overload settings.
	The conveying filter is clogged.	Clean or replace conveying filter.
	Hoses have come off or are loose.	Check for loose hoses.
	The air valves are not opening.	Make sure compressed air is connected and that solenoid valves are operating properly.

Passive Alarms (continued) Hopper Loader

If the Acknowledge Alarm light is blinking, the alarm is a passive alarm. The dryer continues to operate, but this problem could prevent correct drying of your material.

Symptom	Possible Cause	Solution
#1 “loader name” fill time exceeded The fill sensor is not on within 110% of the load time.	The fill and demand sensors are both on.	Either the fill or demand sensor are defective and needs replacing.

Passive Alarms Machine Loader

If the Acknowledge Alarm light is blinking, the alarm is a passive alarm. The dryer continues to operate, but this problem could prevent correct drying of your material.

Symptom	Possible Cause	Solution
#2 Resin loading fault “loader name” The demand sensor located at the machine receiver has not been satisfied.	The sensor is not adjusted properly.	Adjust sensor.
	No material is being conveyed	Check material supply.
	Conveying load time is too short.	Increase load time.
	Conveying blower is not operating.	Check conveying blower fuses and overload settings.
	The conveying filter is clogged.	Clean or replace conveying filter.
	Hoses have come off or are loose.	Check for loose hoses.
	The air valves are not opening.	Make sure compressed air is connected and that solenoid valves are operating properly.

Passive Alarms (continued) Machine Loader

If the Acknowledge Alarm light is blinking, the alarm is a passive alarm. The dryer continues to operate, but this problem could prevent correct drying of your material.

Symptom	Possible Cause	Solution
#2 “loader name” fill sensor fault The demand sensor located at the receiver has failed.	The sensor is not adjusted properly.	Adjust sensor.
#2 “loader name” fill time exceeded	No material is being conveyed.	Check material supply.
	Conveying load time is too short.	Increase load time.
	Conveying blower is not operating.	Check conveying blower fuses and overload settings.
	The conveying filter is clogged.	Clean or replace conveying filter.
	Hoses have come off or are loose.	Check for loose hoses.
The air valves are not opening.	Make sure compressed air is connected and that solenoid valves are operating properly.	

Poor Material Drying Troubleshooting

Occasionally, processing problems that are suspected of being caused by poor drying are eventually determined to be the result of other issues in the process setup. The information can assist you in determining if your drying system is performing properly. However, the only way to know definitely if your material is properly dried is to perform moisture analysis of small samples as it leaves the bottom of the hopper or just as it enters the process. Conair does not sell moisture-analyzing equipment, but there are many brands of this equipment available on the market.

You should also be aware that some processing problems may actually be the result of over drying material. Most materials will degrade to some extent if they are exposed to their specified drying temperature for a time significantly longer than the residence time specified by the supplier. If you want to maintain its dryness, it is recommended that you reduce the process air temperature. If your Conair dryer is equipped with the Setback feature, you should familiarize yourself with it, and make use of it. If not, you may want to contact Conair to determine if it can be added to your dryer.

A majority of customer questions to Conair are related to dewpoint. It is important to realize that dewpoint is one of four requirements that need to be satisfied.

There are four requirements, listed in order of importance, necessary to properly dry hygroscopic plastic resins:

- 1** Drying temperature of the air entering the hopper must be at the proper drying temperature for your material, as specified by your material supplier.
- 2** Residence time is the time, determined by your material supplier, that the material in use must be heated to achieve proper drying temperature.
- 3** Airflow during the process drying circuit must be adequate to carry and distribute the heat throughout the entire bed of material inside the hopper.
- 4** Dewpoint of the process air must be low so it can efficiently collect the moisture as it is released from the heated material and carry it to the dryer to be removed in the desiccant.

Once it is determined which of the four requirements that is not being satisfied, refer to the following list and possible causes and solutions.

Contact Conair
Parts and Service
Phone: 800-458-1960
From outside of the
United States,
Call: 814 437 6861

Poor Material Drying Troubleshooting (continued) Temperature

The temperature of the air entering the hopper must be at the proper drying temperature for your material, as specified by your supplier.

Symptom	Possible Cause	Solution
The temperature of the air entering the hopper is not at proper drying temperature.	Incorrect setpoint.	Refer to the drying specifications for your material and adjust the setpoint to the recommended setpoint. Check Setback Temp to make sure is not active unless you have specifically activated it. If necessary, see the Operation section of this manual for assistance in using the Setback function.
	Not able to achieve setpoint.	Replace any defective process heater, contactors, fuses, etc. Ensure the selected drying temperature is within the design specifications of your dryer.
	Inaccurate process temperature readout.	Ensure the Process RTD is properly positioned in the air stream. Determine if there is a problem in the temperature control circuit and repair or replace any defective components such as RTD, temperature control, circuit boards, etc.

Poor Material Drying Troubleshooting (continued)

Residence Time



The time your material supplier has determined that the material in use must be heated to its drying temperature to achieve proper drying.

Symptom	Possible Cause	Solution
Material residence time is too long or short.	Material level in hopper is too low.	<p>Make sure there is an adequate supply of material to feed the loader on top of the drying hopper.</p> <p>Correct any problems with the conveying system that may be preventing your loader from filling the hopper.</p> <p>If your hopper has a level sensor for maintaining a material level less than completely full, be sure this sensor is adjusted properly.</p>
	Material throughput is too high.	Take any necessary steps, such as slowing down the process, to ensure the material usage is within design specifications of the dryer and hopper.

Poor Material Drying Troubleshooting (continued)

Air Flow

The airflow in the process drying circuit must be adequate to carry and distribute the heat throughout the entire bed of material inside the hopper. If the airflow is too low, the material in the center of the hopper may get heated fully to the drying temperature, but the material against the sidewalls will not. In most cases, the material 2/3 to 3/4 of the way toward the top of the hopper should be heated to the proper drying temperature.

Symptom	Possible Cause	Solution
<p>Too much or too little airflow.</p> <p> NOTE: If there is too much airflow, the material may fluidize inside the hopper, resulting in inconsistent material flow through the hopper, which can negatively impact residence time.</p>	Dirty process air filter.	Clean or replace the process filter.
	Collapsed hoses or holes/leaks in the hoses and hose connection.	Replace any damaged hoses. Tighten all hose clamps to eliminate leaks.
	Airflow restrictions.	Remove any obstructions in the process air circuit.
	Process blower running backwards or performing poorly.	<p>Verify the process blower is running in the correct direction. If backwards, reverse direction by switching any 2 legs of high voltage to the motor.</p> <p> WARNING:</p> <p>Any electrical checks should be performed by a qualified electrician.</p> <p>Repair or replace motor.</p>
Material level in the hopper too low.	Other than running out of material to complete a job, the material level inside the hopper must be a minimum of 50% full. If the hopper is not at least half full, the material in the cone section will not get adequate airflow to dry properly.	

Poor Material Drying Troubleshooting (continued)

Dewpoint

The process air must be at a low dewpoint so it can efficiently collect the moisture as it is released from the heated material and carry it to the dryer to be removed in the desiccant. In most cases, the dryer will dry your material satisfactory if the dewpoint of the air is -20 to -40° F {-29 to -40° C}. If your dryer does not have a dewpoint readout, you can check the dewpoint with a portable dewpoint instrument. Conair sells a variety of portable dewpoint meters. Contact Conair Parts.

Contact Conair
Parts and Service
Phone: 800-458-1960
From outside of the
United States,
Call: 814 437 6861

Symptom	Possible Cause	Solution
Dryer dewpoint is not reaching proper setpoint.	Low regeneration temperature.	Replace or check defective heaters, fuses etc.
	Poor regeneration airflow.	Clean or replace the regeneration filter.
		Ensure the regeneration blower is operating properly and rotating in the correct direction.
		Remove obstructions in the air stream, such as crimped hoses, etc.
High dewpoint, ambient air leaking into the closed loop drying circuit.	High dewpoint, ambient air leaking into the closed loop drying circuit.	Replace damaged hoses and seal any leaks in the process air circuit.
		If using a vacuum loader on the hopper, ensure that the loader shroud is installed in the hopper and that the hopper is completely filled with material.
		If partially filling your hopper, ensure that the hopper loader is sealed against ambient air.
Return air temperature to the dryer is too high.	Return air temperature to the dryer is too high.	Install a gasket between the loader and the top of the hopper.
		Clean the aftercooler coils. <i>See Maintenance section entitled, Cleaning the aftercooler coils.</i>
Poor desiccant performance.	Poor desiccant performance.	<i>See Troubleshooting section entitled, Replacing the desiccant wheel assembly.</i>

Replacing Fuses



NOTE: To locate the appropriate fuse and replacement part, refer to the wiring diagrams that came with your dryer.

- 1 Disconnect and lockout the main power supply.



WARNING: Voltage hazard



Always disconnect and lock out the incoming main power source before opening the electrical enclosure or performing non-standard operating procedures, such as routine maintenance. Only qualified personnel should perform troubleshooting procedures that require access to the electrical enclosure while power is on.

- 2 Open the electrical enclosure door.

- 3 Check the disconnect/fuse. If necessary, replace it with a disconnect/fuse of the same type and rating.

IMPORTANT: Always refer to the wiring diagrams that came with your dryer to locate specific electrical components. Illustrations in the User Guide are intended to be representative only.

Checking or Replacing Temperature Sensors

The MDCW dryer uses RTD sensors to monitor the temperatures of the drying air, the return air, the regeneration outlet, and the regeneration protection and setback at the outlet heater of the hopper.

IMPORTANT: Always refer to the wiring diagrams that came with your dryer to locate specific electrical components. Illustrations in the User Guide are intended to be representative only.

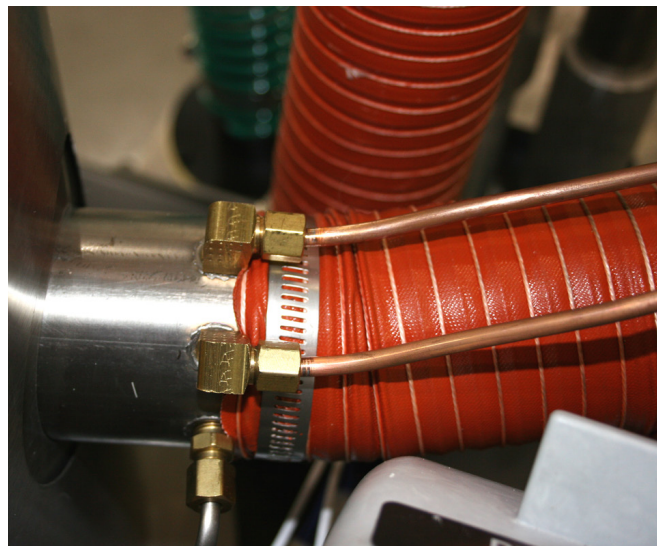

Location of the Process RTD at the Hopper inlet.

Checking or Replacing Temperature Sensors (continued)

To check or replace RTD sensors:



WARNING: Voltage hazard



Always disconnect and lock out the incoming main power source before opening the electrical enclosure or performing non-standard operating procedures, such as routine maintenance. Only qualified personnel should perform troubleshooting procedures that require access to the electrical enclosure while power is on.

- 1 Disconnect and lockout the main power supply.**
- 2 Remove rear plastic cover, as necessary.**
- 3 Locate the RTD sensors.**
- 4 Check the sensor positions and conditions.** Temperature readings will be incorrect, if the sensors are touching the wall of an air hose or pipe or if the sensor or wiring is damaged. The tip of the sensor should be centered within the air hose or pipe. Sensor wires should be attached to the appropriate connection points on the dryer's electrical enclosure or microprocessor board.
- 5 To check with ohm meter, measure the resistance across the RTDs.** The resistance should be approx. 110 ohm at room temperature.
- 6 Replace the sensor, if necessary.**



Replacing the Heaters

Regeneration Heater Tube

 **NOTE:** It is not necessary to remove the plastic cover to perform this procedure.



- 1 Stop the dryer, disconnect the power, and follow proper lockout procedures.**

 **WARNING: Voltage hazard**

 Always disconnect and lock out the incoming main power source before opening the electrical enclosure or performing non-standard operating procedures, such as routine maintenance. Only qualified personnel should perform troubleshooting procedures that require access to the electrical enclosure while power is on.



- 2 Remove the hardware securing the metal cover that surrounds the control cabinet. Remove the control cabinet cover.**

 **CAUTION: Hot Surfaces**

Always protect yourself from hot surfaces inside and outside the dryer and drying hopper.



Control Cabinet Cover

- 3 Working from the front of the machine, locate the regeneration heater tube.**

- 4 Disconnect the heater wiring harnesses at the quick disconnects.**

- 5 Loosen the hose clamps at the top and bottom of the heater tube and remove the heater tube from the dryer.**

- 6 Slide the insulation off or make a straight cut in the insulation, and remove it from the defective heater tube.**

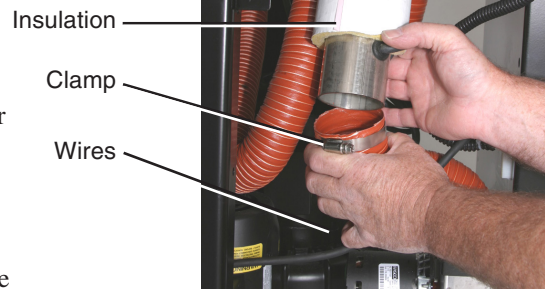

- 7 Check the ID mark on the side of the heater tube for kW rating and voltage. The ID mark is on the outside of the tube near the end with the lead wires.**

- 8 Place the insulation on the new heater tube. Make sure to duct tape the seam that was cut during removal, if necessary.**

- 9 Install the new heater tube and secure it in place with hose clamps at the top and bottom. Be sure the end of the heater tube with the cables is oriented toward the bottom.**

- 10 Connect the heater tube cables to the quick disconnect of the control box wiring harnesses.**

- 11 Reinstall the metal control cabinet cover using the original hardware.**

- 12 Make sure the regeneration heater fuses are not blown before applying power to the new heater.**

- 13 Connect the power and start the dryer.**

Replacing the Heaters (continued)

Process Heater Tube

- 1 Stop the dryer, disconnect the power, and follow proper lockout procedures.

 **WARNING: Voltage hazard**

 Always disconnect and lock out the incoming main power source before opening the electrical enclosure or performing non-standard operating procedures, such as routine maintenance. Only qualified personnel should perform troubleshooting procedures that require access to the electrical enclosure while power is on.

- 2 Disconnect the hose from the process filter, then remove the plastic cover from the back of the dryer.

 **CAUTION: Hot Surfaces**

Always protect yourself from hot surfaces inside and outside the dryer and drying hopper.

- 3 Remove the hardware securing the metal cover that surrounds the control cabinet. Remove the control cabinet cover.

- 4 Locate the process heater tube that extends through the frame, at the back of the machine.

- 5 Disconnect the heater wiring harnesses at the quick disconnects.

- 6 Loosen the hose clamps at the top and bottom of the heater tube.

- 7 Loosen the hose clamp securing the heater tube in place and remove the tube from the unit.

- 8 Slide the insulation off, or make a straight cut in the insulation and remove it from the defective heater tube.

- 9 Check the ID mark on the side of the heater tube for the kW rating and voltage and replace with a new heater tube with the same ratings. The ID mark is on the outside of the tube near the end with the lead wires.

- 10 Place the insulation on the new heater tube. Make sure to duct tape the seam that was cut during removal, if necessary.

- 11 Secure the new heater to the support tab with a hose clamp. Be sure the end of the heater tube with the cables is oriented toward the bottom.

- 12 Connect the hoses to the top and bottom of the heater tube, and secure with hose clamps. Be sure that the insulation of the top hose is in place and in good condition.

- 13 Connect the heater tube cables to the quick disconnects of the control box wiring harness.

- 14 Make sure the process heater fuses are not blown before applying power to the new heater.

- 15 Connect the power and start the dryer.



Control Cabinet Cover



Clamp Insulation



Process Heater

Replacing the Desiccant Wheel Assembly

If the desiccant becomes clogged or contaminated, you should replace the desiccant wheel to ensure optimum performance.



- 1 Stop the dryer, disconnect the power, and follow proper lockout procedures.

 **WARNING: Voltage hazard**

 Always disconnect and lock out the incoming main power source before opening the electrical enclosure or performing non-standard operating procedures, such as routine maintenance. Only qualified personnel should perform troubleshooting procedures that require access to the electrical enclosure while power is on.



- 2 Remove the plastic cover from the back of the dryer.

 **CAUTION: Hot Surfaces**

Always protect yourself from hot surfaces inside and outside the dryer and drying hopper.



- 3 Disconnect wiring from the display board and loader switches, then remove the front plastic cover.

 **NOTE:** The two halves of the display must be separated to disconnect the wires from the display.

- 4 Remove the hardware securing the metal cover that surrounds the control cabinet. Remove the control cabinet cover.

- 5 Disconnect all the hoses and RTDs from the wheel assembly. Be sure to note the positions of each.

- 6 Disconnect wires to the wheel motor.

- 7 Remove four bolts securing the wheel assembly to the frame, then remove the desiccant wheel assembly from the dryer.

- 8 Position the new wheel assembly on the frame, with the motor to the right, as viewed from the front.

- 9 Bolt the wheel assembly to the frame.

- 10 Reconnect the motor wires.

- 11 Reconnect the hoses and RTDs to their original positions.

- 12 Reinstall the metal control cabinet cover using the original hardware.

- 13 Bolt the front plastic cover in place, and reconnect the wires.

- 14 Bolt the rear plastic cover in place.



Process Heater

We're Here to Help

Conair has made the largest investment in customer support in the plastics industry. Our service experts are available to help with any problem you might have installing and operating your equipment. Your Conair sales representative also can help analyze the nature of your problem, assuring that it did not result from misapplication or improper use.

Additional manuals and prints for your Conair equipment may be ordered through the Customer Service or Parts Department for a nominal fee.

Most manuals can be downloaded free of charge from the product section of the Conair website.

www.conairgroup.com

How to Contact Customer Service

To contact Customer Service personnel, call:



 **NOTE:** Normal operating hours are 8:00 am - 5:00 pm EST. After hours emergency service is available at the same phone number.

From outside the United States, call: 814-437-6861

You can commission Conair service personnel to provide on-site service by contacting the Customer Service Department. Standard rates include an on-site hourly rate, with a one-day minimum plus expenses.

Before You Call...

If you do have a problem, please complete the following checklist before calling Conair:

- Make sure you have all model, control type from the serial tag, and parts list numbers for your particular equipment. Service personnel will need this information to assist you.
- Make sure power is supplied to the equipment.
- Make sure that all connectors and wires within and between control systems and related components have been installed correctly.
- Check the troubleshooting guide of this manual for a solution.
- Thoroughly examine the instruction manual(s) for associated equipment, especially controls. Each manual may have its own troubleshooting guide to help you.

Equipment Guarantee

Conair guarantees the machinery and equipment on this order, for a period as defined in the quotation from date of shipment, against defects in material and workmanship under the normal use and service for which it was recommended (except for parts that are typically replaced after normal usage, such as filters, liner plates, etc.). Conair's guarantee is limited to replacing, at our option, the part or parts determined by us to be defective after examination. The customer assumes the cost of transportation of the part or parts to and from the factory.

Performance Warranty

Conair warrants that this equipment will perform at or above the ratings stated in specific quotations covering the equipment or as detailed in engineering specifications, provided the equipment is applied, installed, operated, and maintained in the recommended manner as outlined in our quotation or specifications.

Should performance not meet warranted levels, Conair at its discretion will exercise one of the following options:

- Inspect the equipment and perform alterations or adjustments to satisfy performance claims. (Charges for such inspections and corrections will be waived unless failure to meet warranty is due to misapplication, improper installation, poor maintenance practices, or improper operation.)
- Replace the original equipment with other Conair equipment that will meet original performance claims at no extra cost to the customer.
- Refund the invoiced cost to the customer. Credit is subject to prior notice by the customer at which time a Return Goods Authorization Number (RGA) will be issued by Conair's Service Department. Returned equipment must be well crated and in proper operating condition, including all parts. Returns must be prepaid.

Purchaser must notify Conair in writing of any claim and provide a customer receipt and other evidence that a claim is being made.

Warranty Limitations

Except for the Equipment Guarantee and Performance Warranty stated above, Conair disclaims all other warranties with respect to the equipment, express or implied, arising by operation of law, course of dealing, usage of trade or otherwise, including but not limited to the implied warranties of merchantability and fitness for a particular purpose.

Cleaning the Precooler Coils

If you have the optional precooler, you need to clean the coils to keep them working efficiently. Cleaning frequency depends on the type and amount of material you process.

- 1 Stop the dryer and lockout the main power.



WARNING: Voltage hazard



Always disconnect and lock out the incoming main power source before opening the electrical enclosure or performing non-standard operating procedures, such as routine maintenance. Only qualified personnel should perform troubleshooting procedures that require access to the electrical enclosure while power is on.



- 2 Turn off the water flow to the water supply line. Disconnect supply and return lines.



NOTE: If an optional flow control was added with the precooler, remove the compression fitting from the precooler inlet. Loosen the fitting on the flow control, then swing the copper water supply tube out and away from the precooler inlet.

- 3 Remove the two (2) nuts securing the precooler in the housing.

TIP: If the precooler (without a flow control) was installed using the recommended 24 inch {61 cm} of flexible hoses, there is no need to disconnect the hoses from the precooler inlet and outlet.

- 4 Remove the precooler assembly from the precooler housing.

- 5 Clean the assembly using a mild soap and water. Let the assembly dry thoroughly before installation.

- 6 Inspect the condition of the gasket. If it is damaged, replace the gasket.

- 7 Reassemble by repeating the steps in reverse order.

- 8 Connect the water supply line to the inlet. If a manual shut off valve is used, it should be mounted on the inlet line as well.

- 9 Connect the outlet of the precooler to the inlet of the flow control valve using the pre-shaped copper tubing and compression fittings provided.

Modbus Communications

Description of Modbus Communications

The DC-A series of products from Conair use standard TCP/IP Modbus and CIP communications protocols to allow the user to access the PLC for supervisory type functions. For example, you may want to display the drying temperature for all hoppers in a facility in one central location. By connecting all the dryers to a central computer, the temperatures and setpoints can be displayed in one location using a standard SCADA software program such as Wonderware or RSView.

Installing the Modbus Communication Hardware

The hardware required for Modbus communications is included with the Ethernet option when the dryer is shipped. Connectors and cabling must be supplied by the user or ordered from Conair. Shielded category 5e Ethernet cable and connectors are recommended.

Using the Modbus Parameter List

The Modbus interface uses standard Modbus protocol to communicate with a common controls system. The data that may be retrieved is arranged in a tag name/Modbus address list. By using the Modbus register read and write commands, the desired data may be read from or written to the controller. The list of data that may be set or retrieved with the DC-A control system is arranged by CIP tag name then Modbus register. [See Modbus Address List later in this Appendix](#) for the list of tag names and corresponding Modbus registers. The data types and Modbus message command types are included in the list.



CAUTION:

Writing to a location with improper data, or writing to an incorrect location outside of the specified locations on the list may cause your DC-A control system to become inoperative or to operate in a manner that may damage your process. Be certain that you understand each parameter and its effect before changing anything. Conair recommends that you initially attempt to read from the 3X registers and do not attempt any writes. Once the information you are trying to read has been confirmed as accurate, you can program your new/additional data.

Ethernet Communications

Description of Ethernet Communications

Modbus TCP/IP is a protocol that takes the basic Modbus command set that was originally developed for serial communications, and applies it to the Ethernet standard via TCP/IP protocol.

Installing the Ethernet Communication Hardware

The DC-A control is shipped with a default PLC Industrial Protocol (IP) address of 010.001.011.005. In order for your dryer to communicate with your network, this default IP address may need to be changed to match the network structure used in your plant. Changing the IP address is accomplished through a project software download or at some point after initial product release, through the operator interface terminal.

 **NOTE:** if customer specific addresses are required, they can be provided at the time of order and the dryer will ship with the Ethernet addresses preset in the dryer.

Modbus Communications (Continued)

To change the IP address:

- 1** Enter the admin password. See your dryer manual for directions if necessary.
- 2** Once the password has been entered, go to “Dryer settings”>”Dryer setup”.
- 3** First enter the new IP address, subnet mask and gateway address for the PLC.
- 4** Next enter the IP address, subnet mask and gateway address for the operator interface terminal. Also enter the OIT target IP address. Note: This is the PLC address.

Using the Ethernet Parameter List

Please refer to page Appendix A for a list of the parameters that are available with the Modbus TCP/IP interface.



CAUTION:

Writing to a location with improper data, or writing to an incorrect location outside of the specified range may cause your DC-A control system to become inoperative or to operate in a manner that may damage your process. Be certain that you understand each parameter and its effect before changing anything. Conair recommends that you initially attempt to read from the 3X registers and do not complete any writes. Once the information you are trying to read has been confirmed as accurate, you can now program in your new or additional data.



NOTE: The list of parameters that may be read and written to via Modbus TCP/IP is extensive. Some of these parameters are naturally a part of the operation of the machine and others may be obscure configuration settings. The parameter list in Appendix A includes a column with a recommendation as to whether the parameter should be accessed by a user program. Addresses that are not consecutive indicate that there are other parameters present which are not recommended for usage by the user.

Modbus Address List

Tag Name	Modbus	Type	E/U	Access	Notes
User_Autostart_Day_SP	400544	UINT	Day	RW	Range 1-31
User_Autostart_Hour_SP	400545	UINT	Hour	RW	Range 1-24
User_Autostart_Minute_SP	400546	UINT	Minute	RW	Range 0-59
User_Control_Bits	0X	BOOL	N/A	RW	See User_Bits page
User_Current_User		STRING	N/A	RO	HMI logged in user name
User_Current_User_Level	300538	INT	N/A	RO	HMI logged in user level
User_Dewpoint_High_Alm	400547	REAL	F/C	RW	high dewpoint alarm set point
User_DM_High_Alarm_Pos	400549	USINT	N/A	RW	Drying monitor high alarm position, 0 = T2, 1 = T3, 2 = T4, 3 = T5
User_DM_High_Alarm_SP	400550	REAL	F/C	RW	Drying monitor high alarm set point
User_DM_Low_Alarm_Pos	400552	USINT	N/A	RW	Drying monitor low alarm position, 0 = T2, 1 = T3, 2 = T4, 3 = T5
User_DM_Low_Alarm_SP	400553	REAL	F/C	RW	Drying monitor low alarm set point
User_Dryer_State	300501	INT	N/A	RO	0=Powering up 1=Standby, 2=Starting 3=Stopping 4=Running, 5= Passive Alarm 6=Shutdown Alarm 7=Comms Loss
User_Dryer_Type	300500	INT	N/A	RO	1=Central 2=Standard 3=MDC with conveying 4=MDC non-conveying
User_DryingMon_T1	300522	REAL	F/C	RO	Optional, drying monitor T1 temperature
User_DryingMon_T2	300524	REAL	F/C	RO	Optional, drying monitor T2 temperature
User_DryingMon_T3	300526	REAL	F/C	RO	Optional, drying monitor T3 temperature
User_DryingMon_T4	300528	REAL	F/C	RO	Optional, drying monitor T4 temperature
User_DryingMon_T5	300530	REAL	F/C	RO	Optional, drying monitor T5 temperature
User_DryingMon_T6	300532	REAL	F/C	RO	Optional, drying monitor T6 temperature
User_Energy_Hours	300516	REAL	Hours	RO	Total measurement hours
User_Energy_Last_Hour	300518	REAL	kWh	RO	Energy consumption in the last hour
User_Energy_Total_kWh	300520	REAL	kWh	RO	Total dryer kWh
User_From_Process_Dewpoint_Actual	300536	REAL	F/C	RO	Optional return air dew point
User_MatI_Exit_Temp	300534	REAL	F/C	RO	Optional, hopper material exit temperature
User_Process_OnTime	300512	REAL	%	RO	Process heater % on-time
User_ProcSP_Max	400540	REAL	F/C	RW	Process temperature maximum set point
User_ProcSP_Min	400542	REAL	F/C	RW	Process temperature minimum set point
User_RA_Temp_At_Hopper_Actual	300504	REAL	F/C	RO	Hopper outlet temperature
User_RA_Temp_At_Wheel_Actual	300510	REAL	F/C	RO	Wheel inlet temperature
User_Regen_OnTime	300514	REAL	%	RO	Regen heater % on-time
User_Regen_Temp_Actual	300506	REAL	F/C	RO	Regeneration temperature
User_SB_Reset_SP	400536	REAL	F/C	RW	Setback reset to process set point
User_SB_ReturnAir_SP	400534	REAL	F/C	RW	Setback hopper outlet set point
User_SB_Setback_SP	400532	REAL	F/C	RW	Setback to this set point
User_Status_Bits	1X	BOOL	N/A	RO	See User_Bits page
User_To_Process_Dewpoint_Actual	300508	REAL	F/C	RO	To process dew point temperature
User_To_Process_Dewpoint_Setpoint	400538	REAL	F/C	RW	To process dew point control set point
User_To_Process_Temp_Actual	300502	REAL	F/C	RO	Material drying temperature
User_To_Process_Temp_Setpoint	400530	REAL	F/C	RW	Material drying temperature set point

(Continued)

Modbus Address List (Continued)

Tag Name	Modbus	Type	Access	Element	Description
User_Control_Bits	0X	Bool Array	RW		HMI or Remote User Control Bools
	000001			[1]	Start PB
	000002			[2]	Stop PB
	000003			[3]	Reserved
	000004			[4]	Reserved
	000005			[5]	Reserved
	000006			[6]	Reserved
	000007			[7]	Engineering Units (0=english, 1=Metric)
	000008			[8]	Reserved
	000009			[9]	Reserved
	000010			[10]	Reserved
	000011			[11]	Reserved
	000012			[12]	Acknowledge Alarm
	000013			[13]	Energy Meter Enable
	000014			[14]	Dew Point Control Enable
	000015			[15]	Reserved
	000016			[16]	Auto Start Enable
	000017			[17]	Reserved
	000018			[18]	Reserved
	000019			[19]	Return Air Temperature Control Enable
	000020			[20]	Setback Enable
	000021			[21]	SetBack Mode (0=Man, 1=Auto)
	000022			[22]	Reserved
	000023			[23]	Reserved
	000024			[24]	Reserved
	000025			[25]	Reserved
	000026			[26]	Reserved
	000027			[27]	Reserved
	000028			[28]	Reserved
	000029			[29]	Reserved
	000030			[30]	Reserved
	000031			[31]	#1 Loader enable, (True = enabled)
000032	[32]	#2 Loader enable, (True = enabled)			

Modbus Address List (Continued)

Tag Name	Modbus	Type	Access	Element	Description
User_Status_Bits	1X	Bool Array	RO		HMI or Remote User Status Booleans
	100001			[1]	Dryer (On/Off)
	100002			[2]	Reserved
	100003			[3]	Reserved
	100004			[4]	Reserved
	100005			[5]	Auto Start (Armed/Disarmed)
	100006			[6]	SetBack Enabled
	100007			[7]	SetBack Active
	100008			[8]	Dew Point Control Active
	100009			[9]	Wheel Clean Cycle Active
	100010			[10]	Spare
	100011			[11]	Spare
	100012			[12]	Spare
	100013			[13]	Spare
	100014			[14]	Spare
	100015			[15]	Spare
	100016			[16]	Spare
	100017			[17]	Spare
	100018			[18]	Spare
	100019			[19]	Spare
	100020			[20]	Spare
	100021			[21]	Spare
	100022			[22]	Spare
	100023			[23]	Spare
	100024			[24]	Spare
	100025			[25]	Spare
	100026			[26]	Spare
	100027			[27]	Spare
	100028			[28]	Spare
	100029			[29]	Spare
	100030			[30]	Spare
	100031			[31]	#1 Loader is enabled when true
100032	[32]	#2 Loader is enabled when true			

(Continued)

Modbus Address List (Continued)

Tag Name	Modbus	Type	Access		Description
Alarms_Shutdown	1X	Bool Array	RW		Shutdown Alarms to the HMI or Remote user
	100101			[1]	E-stop pressed - Shutdown
	100102			[2]	Spare
	100103			[3]	Process or regeneration heater safety switch open - Shutdown
	100104			[4]	Process temperature control fault- Shutdown
	100105			[5]	Process RTD fault- Shutdown
	100106			[6]	Process blower overload- Shutdown
	100107			[7]	Process Blower Drive Fault- Shutdown
	100108			[8]	3 phase power supply error - Shutdown
	100109			[9]	High return air temperature - Shutdown
	100110			[10]	Spare
	100111			[11]	Spare
	100112			[12]	Regeneration heater safety switch open - Shutdown
	100113			[13]	Regeneration temperature control fault - Shutdown
	100114			[14]	Regeneration RTD fault- Shutdown
	100115			[15]	Regen blower overload - Shutdown
	100116			[16]	Spare
	100117			[17]	Desiccant wheel not rotating - Shutdown
	100118			[18]	Startup failed at process blower - Shutdown
	100119			[19]	Startup failed at regen blower - Shutdown
	100120			[20]	Startup failed at isolation contactor - Shutdown
	100121			[21]	Startup failed at SSRs - Shutdown
	100122			[22]	Spare
	100123			[23]	Spare
	100124			[24]	Spare
	100125			[25]	Spare
	100126			[26]	Spare
	100127			[27]	Spare
	100128			[28]	Spare
	100129			[29]	Spare
	100130			[30]	Spare
	100131			[31]	Spare
100132	[32]	Spare			

Modbus Address List (Continued)

Tag Name	Modbus	Type	Access	Element	Description
Alarms_Passive		Bool Array	RO		Passive Alarms to the HMI or Remote
	100201			[1]	Drying monitor low temperature - Passive
	100202			[2]	Drying monitor high temperature - Passive
	100203			[3]	Clean or replace regeneration filter - Passive
	100204			[4]	Dewpoint high - Passive
	100205			[5]	Clean or replace process filter - Passive
	100206			[6]	Reserved - Passive
	100207			[7]	Reserved - Passive
	100208			[8]	Reserved - Passive
	100209			[9]	Spare - Passive
	100210			[10]	Spare - Passive
	100211			[11]	Spare - Passive
	100212			[12]	Spare - Passive
	100213			[13]	Return air RTD fault - Passive
	100214			[14]	Hopper outlet RTD fault - Passive
	100215			[15]	Drying monitor T1 RTD fault - Passive
	100216			[16]	Drying monitor T2 RTD fault - Passive
	100217			[17]	Drying monitor T3 RTD fault - Passive
	100218			[18]	Drying monitor T4 RTD fault - Passive
	100219			[19]	Drying monitor T5 RTD fault - Passive
	100220			[20]	Drying monitor T6 RTD fault - Passive
	100221			[21]	#1 Resin loading fault "loader name" - Passive
	100222			[22]	#1 "loader name" fill sensor fault - Passive
	100223			[23]	#1 "loader name" fill time exceeded - Passive
	100224			[24]	Spare Receiver 1
	100225			[25]	#2 Resin loading fault "loader name" - Passive
	100226			[26]	#2 "loader name" fill sensor fault - Passive
	100227			[27]	#2 "loader name" fill time exceeded - Passive
	100228			[28]	Spare Receiver 2
	100229			[29]	Spare Receiver 2
	100230			[30]	Conveying/pump overload - Passive
	100231			[31]	Spare
100232	[32]	Spare			

Optional Memory Backup Module

If for some reason you lose the program or have to replace the PLC:

- 1 Turn of the power.**
- 2 Unplug the RTD module on the left side of the PLC.**
- 3 Plug in the memory module on the left side** where you removed the RTD module.
- 4 Turn the power on and the program loads.** When the LEDs stop flickering, the program has fully loaded.
- 5 Turn the power off.**
- 6 Unplug and remove the memory module.**
(Typically in a box marked “EEPROM backup”).

IMPORTANT

This is an EEPROM software backup.
It should only be installed when replacing
the PLC to restore factory software.

- 7 Reinstall the RTD module.**
- 8 Turn the power on.** The dryer should return to normal operation.

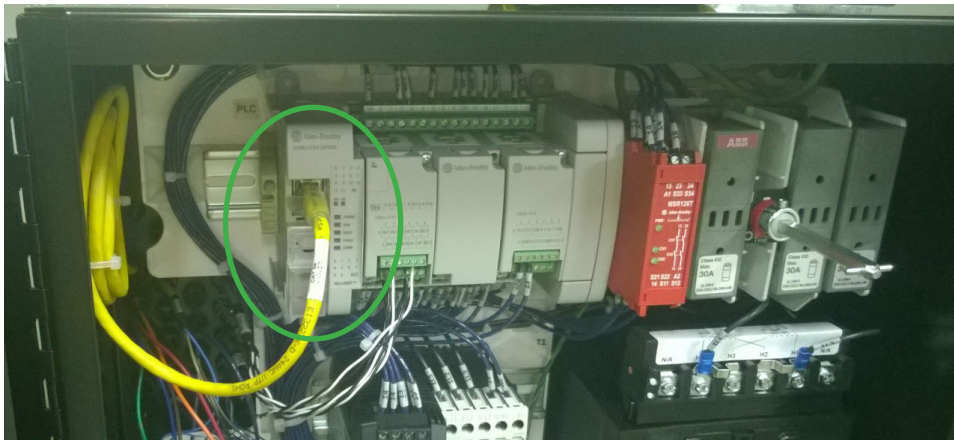

Changing the IP Address on a DC-A Dryer

1 To change the Ethernet settings on the DC-A dryer you will first have to login as user “admin” or higher. After logging in, access the “Dryer set-up” screen.

NOTE: When changing the Ethernet addresses, there are 3 IP address settings involved.
(1) the actual IP address in the PLC.
(2) that same address, as the target address in the HMI.
(3) the actual HMI adaptor IP address.

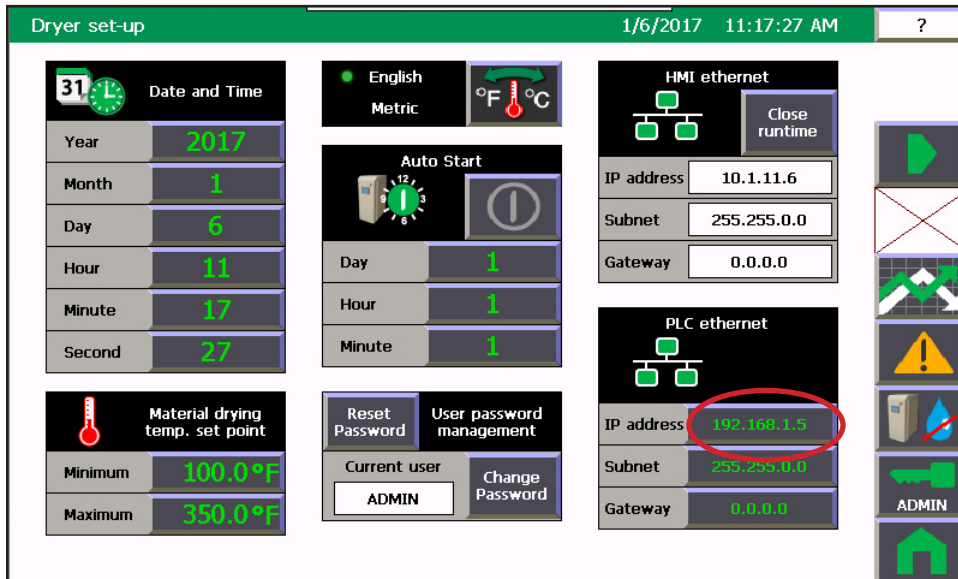

WARNING:

The PLC must be set first. Once its IP address is changed, the touch screen will lose communications. Select the PLC setting you wish to change.

2 In this example we will change the IP address to 192.168.1.5 and press enter.



(Continued)

Changing the IP Address on a DC-A Dryer (Continued)

When the displayed settings no longer match the current settings the “Apply change” pushbutton becomes visible.

 **WARNING:**

Communications will be lost on the next step. If you’re only changing the gateway address or subnet mask communications may not be lost.

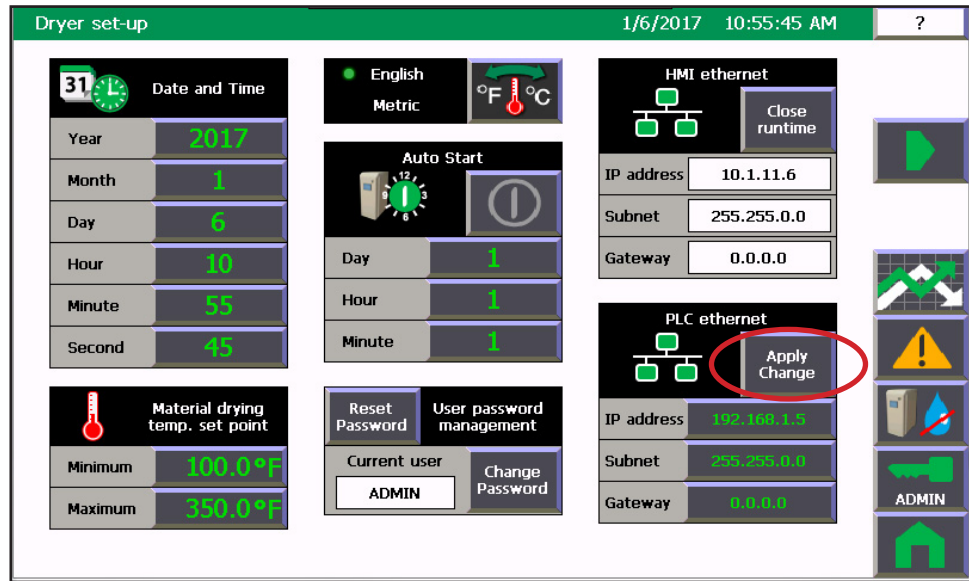

- 3 Verify the new IP address and if it is correct select the “Apply change” push button. Now communications loss warnings appear on the screen.

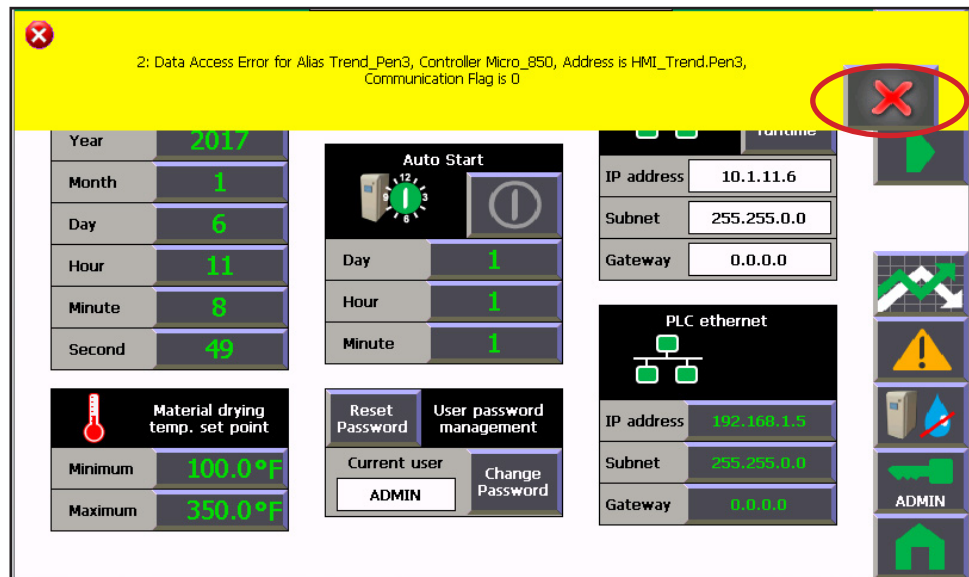

You will have to select the red “X” push button several times. There will be a warning for every PLC tag on the current screen.

Changing the IP Address on a DC-A Dryer (Continued)

- 4 Select the “Close runtime” push button located just above the HMI Ethernet settings to access the HMI Ethernet settings.

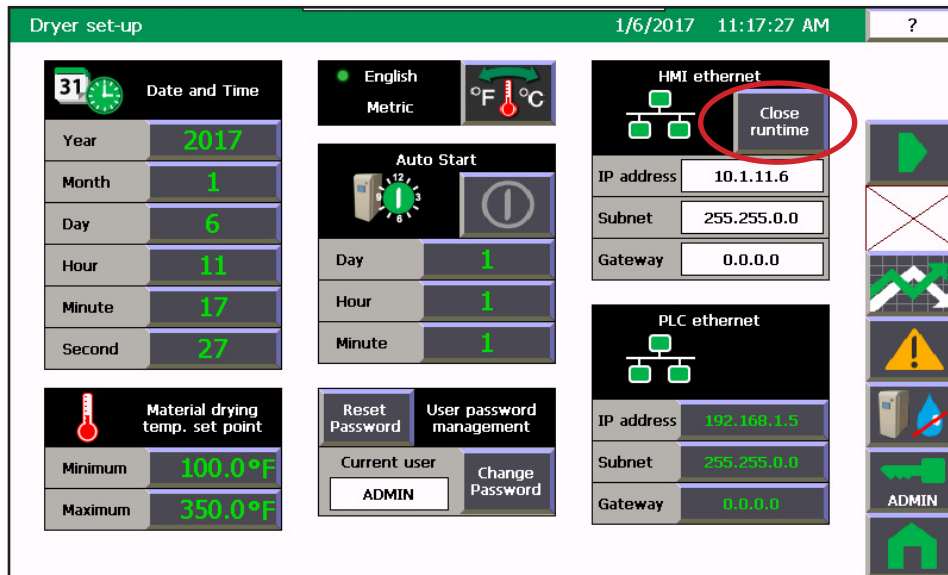

The screen will go blank while the touch screen operating system loads.



Changing the IP Address on a DC-A Dryer (Continued)

Once the OS is loaded you will continue to get communications warnings until you stop the runtime.

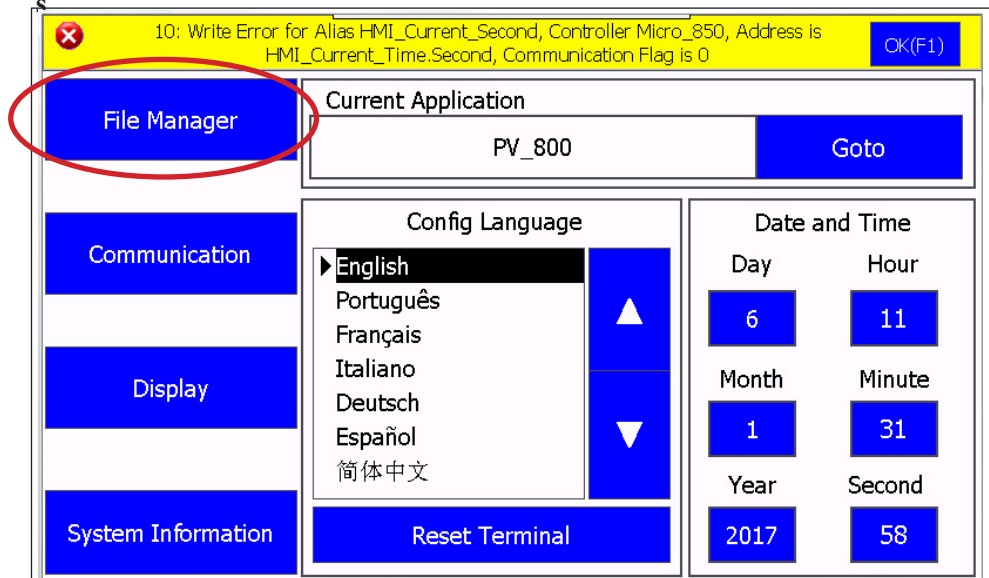

5 Select the “File Manager” push button.

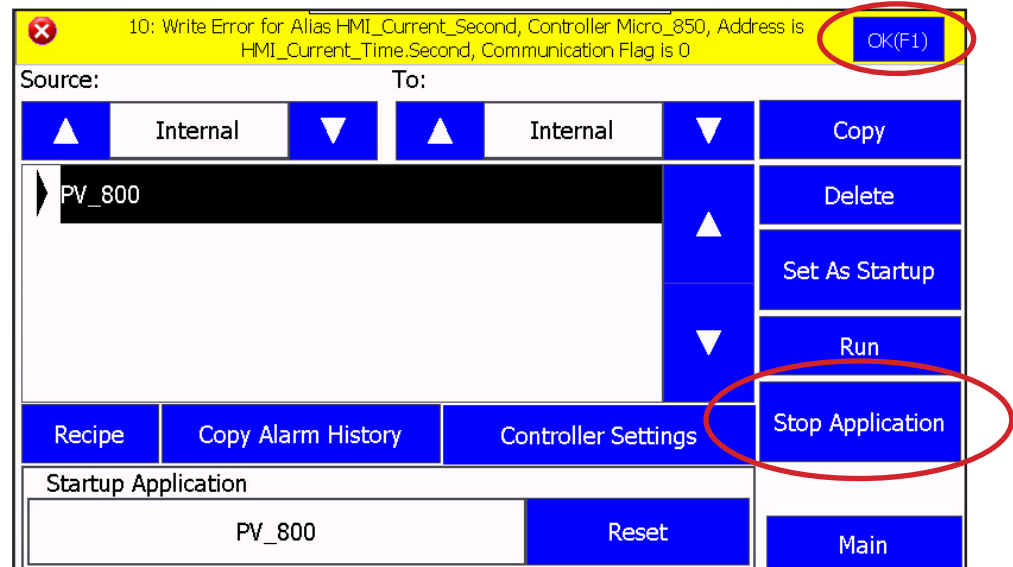

6 Select the “Stop Application” push button.
Now pick “yes” on the confirmation pop-up.

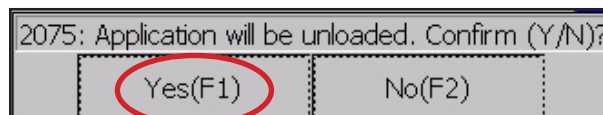

You will get a blank “unloading” screen for several seconds. You can now close the warnings by selecting the “Ok” push button several times.

Changing the IP Address on a DC-A Dryer (Continued)

7 Next, to set the new touch screen target IP address for the PLC select the “Controller Settings” push button.

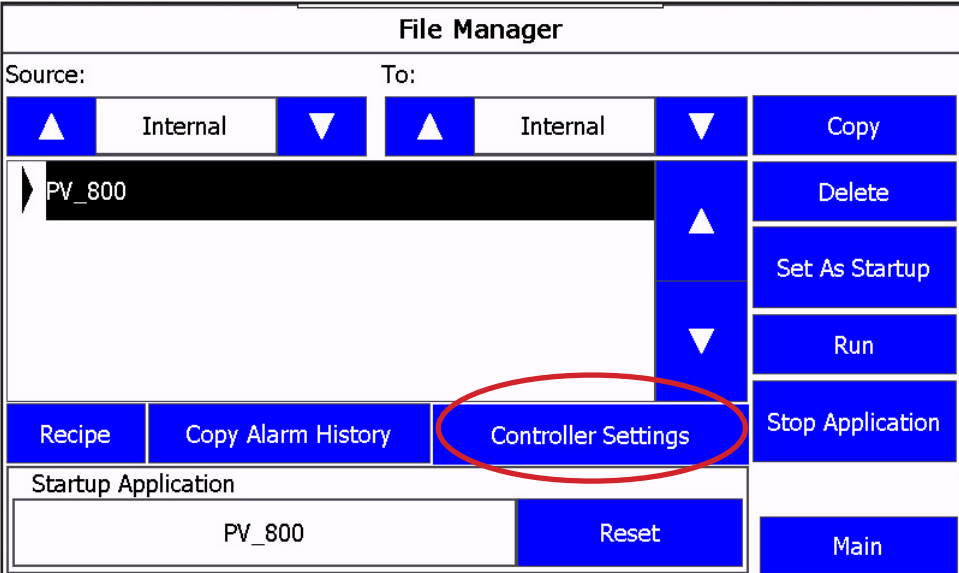

8 Pick on the old PLC IP address to bring up the keypad and enter the same new IP address that was entered into the PLC from the runtime in step 2.

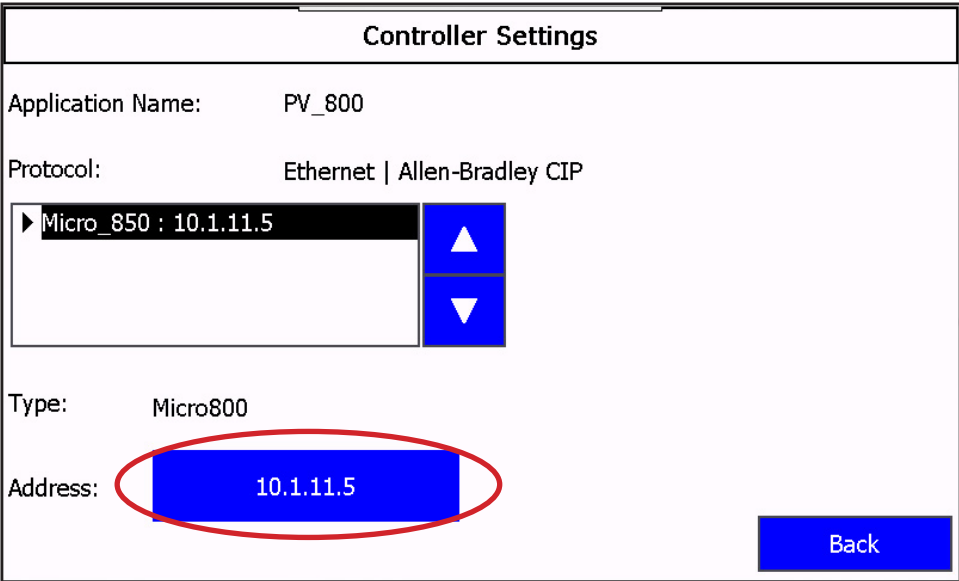

Changing the IP Address on a DC-A Dryer (Continued)

9 After entering the new address select the “Back” push button.

Controller Settings	
Application Name:	PV_800
Protocol:	Ethernet Allen-Bradley CIP
▶ Micro_850 : 10.1.11.5	▲ ▼
Type:	Micro800
Address:	10.1.11.5
	Back

10 Select the “Main” push button..

File Manager			
Source:	To:		
▲ Internal ▼	▲ Internal ▼		Copy
▶ PV_800	▲ ▼		Delete
			Set As Startup
			Run
Recipe	Copy Alarm History	Controller Settings	Stop Application
Startup Application			
	PV_800	Reset	Main

Changing the IP Address on a DC-A Dryer (Continued)

11 From the Main screen select the “Communication” push button.

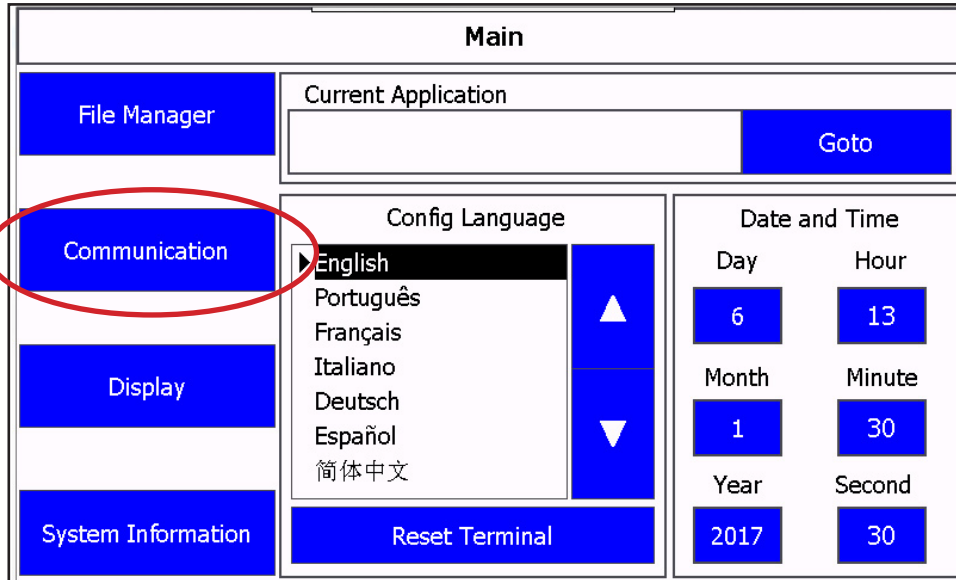

12 From the Communication screen select the “Set Static IP Address” push button.

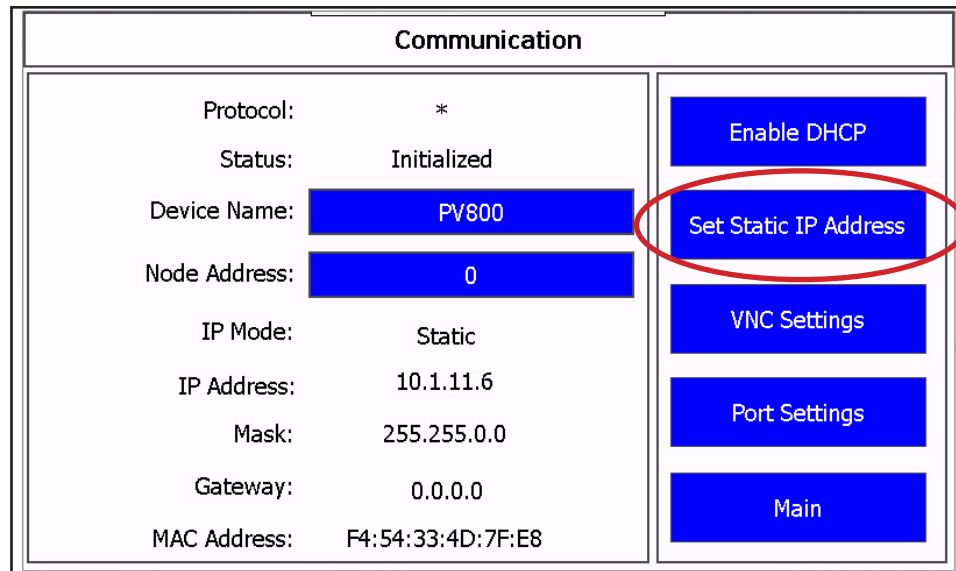

(Continued)

Changing the IP Address on a DC-A Dryer (Continued)

13 From the Static IP Address screen select the “IP Address” push button.

The screenshot shows a screen titled "Static IP Address". It contains three input fields: "IP Address:" with the value "10.1.11.6", "Mask:" with the value "255.255.0.0", and "Gateway:" with the value "0.0.0.0". A blue "Back" button is located in the bottom right corner. A red oval highlights the "IP Address:" field.

14 Enter the new IP address for the HMI and select enter.

The screenshot shows the same "Static IP Address" screen as in step 13, but with a virtual keyboard overlay. The text "192.168.1.6" is entered in the "IP Address:" field. The virtual keyboard includes function keys (Esc, F1-F12, Home, End), a numeric keypad, and a QWERTY layout. The "Enter" key (represented by a right-pointing arrow) is highlighted with a red oval. A blue "Back" button is visible in the bottom right corner.

Changing the IP Address on a DC-A Dryer (Continued)

15 Select the “Back” push button.

Static IP Address	
IP Address:	10.1.11.6
Mask:	255.255.0.0
Gateway:	0.0.0.0
	Back

16 Select the “Main” push button.

Communication	
Protocol:	*
Status:	Initialized
Device Name:	PV800
Node Address:	0
IP Mode:	Static
IP Address:	10.1.11.6
Mask:	255.255.0.0
Gateway:	0.0.0.0
MAC Address:	F4:54:33:4D:7F:E8
	Enable DHCP
	Set Static IP Address
	VNC Settings
	Port Settings
	Main

(Continued)

Changing the IP Address on a DC-A Dryer (Continued)

17 Select the “File Manager” push button.

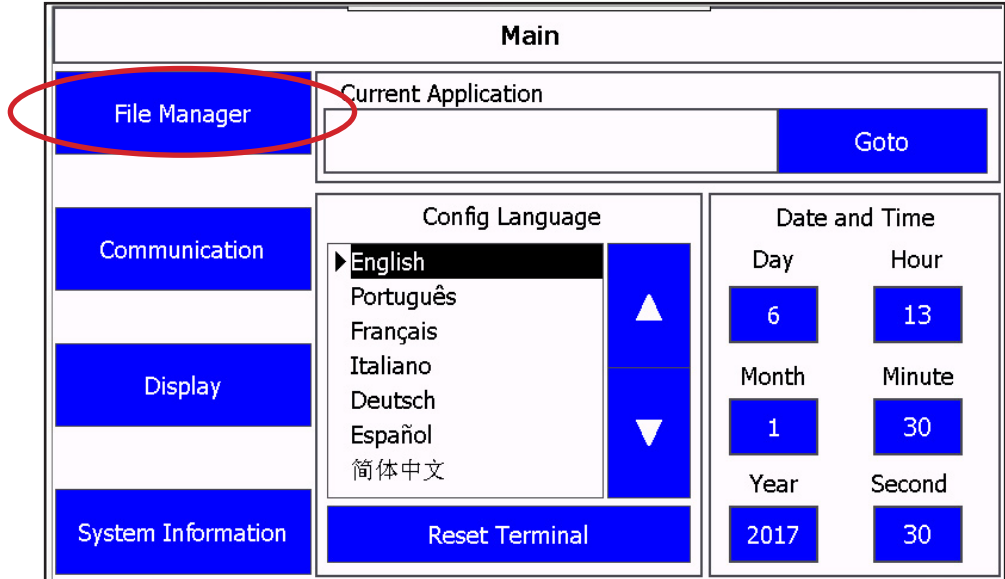

18 The Ethernet setup is complete. Select the “Run” push button to launch the runtime application.

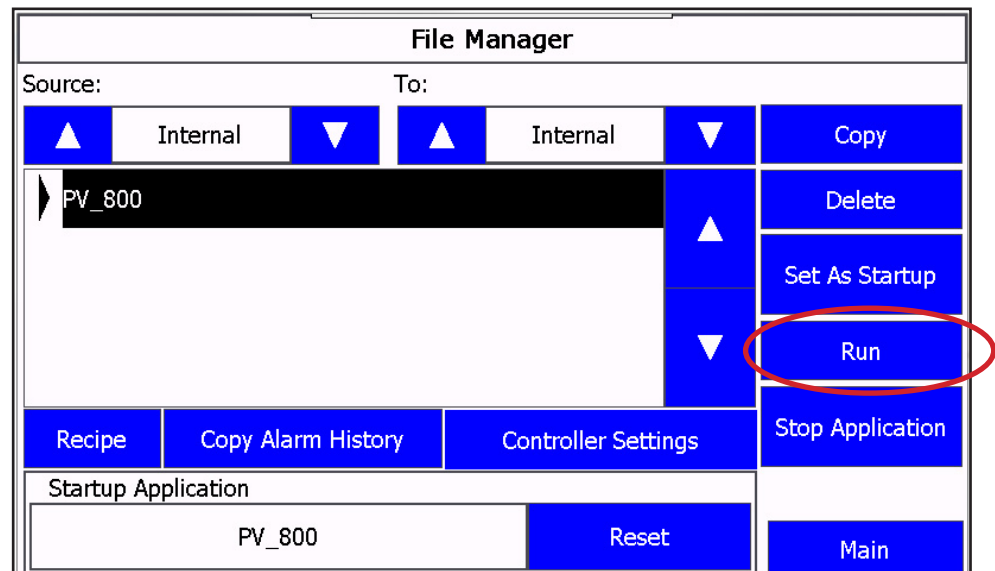

There will be a blank screen displaying “Loading...” for several seconds, then the DC-A dryer home screen appears. Congratulations you successfully changed the Ethernet settings!

Virtual Network Computing

Virtual Network Computing (VNC) allows you to remotely connect to a PanelView 800 terminal, either over the local network or the Internet. With VNC you can interact with the terminal without having to be physically at the terminal location. It transmits keyboard and mouse actions from your computer to the terminal.

Guidelines for Using VNC

- It is recommended to enable only the view-only access to the terminal. Enabling control access increases the security risk if the password is compromised.
- Only one active VNC connection is supported and the terminal will reject additional connection requests.
- For better performance when using VNC, it is recommended to use a 100 Mbps connection. Using a 10 Mbps connection may result in lower performance, such as a slower refresh rate.
- If you are using a VNC Viewer application that supports configurable refresh rate, set the minimum refresh rate to 500 milliseconds.
- Terminate the VNC connection before performing a firmware update as it may interfere with the process.
- You cannot calibrate the touchscreen using VNC. If you have triggered the calibration process, you can press the “ESC” key on the keyboard to cancel the procedure.
- The mouse action “Press and hold” is not supported over VNC

Recommended VNC Clients and Settings

There are many VNC viewer applications you can use to connect with the terminal. These are the recommended VNC client for use with PanelView 800 terminals.

Recommended VNC Clients and Settings

Client Name	Remote Connection	Recommended Settings
Tight VNC	PC/Laptop - Windows 7	Change Preferred Encoding from “Tight” to “Hextile” for smoother screen switching.
Real VNC	Mobile and Tablet - IOS	None
	Mobile and Tablet - Android	None
	PC/Laptop - Windows 7	<ul style="list-style-type: none"> • Change Color Level from “pal8” to “Full” for a clearer display. • Change Security Notification Timeout from “2500” to “0” in the client options.
Mocha VNC	Mobile and Tablet - IOS	<ul style="list-style-type: none"> • Disable the “32-bit color” option in the configuration settings for a clearer display. • Disable “Zoom to Screen height” option for a better screen view.
	Mobile and Tablet - Android	<ul style="list-style-type: none"> • Enable the “8-bit color” option in the configuration settings for a clearer display
	Mobile = Windows Mobile	
Ultra VNC	PC/Laptop - Windows 7	<ul style="list-style-type: none"> • None

(Continued)

Virtual Network Computing (Continued)

Configure VNC Settings

Follow these steps to configure the VNC settings for your terminal.

- 1 Go to the main configuration screen.

Main	
File Manager	Current Application <input type="text"/> Goto
Communication	Config Language ▶ English Português Français Italiano Deutsch Español ☑ 体中文
Display	Date and Time Day: 14 Hour: 10 Month: 1 Minute: 30 Year: 2015 Second: 56
System Information	Reset Terminal

- 2 Press Communication.

Communication	
Protocol: *	Disable DHCP
Status: Unavailable	Set Static IP Address
Device Name: PV800T7T	VNC Settings
Node Address: 0	Port Settings
IP Mode: DHCP	Main
IP Address: 0.0.0.0	
Mask: 0.0.0.0	
Gateway: 0.0.0.0	
MAC Address: XX:XX:XX:XX:XX	

Virtual Network Computing (Continued)

3 Press VNC Settings.

VNC Settings	
Server: <input type="button" value="Enable / Disable"/> Access: <input type="button" value="View-Only / Control"/>	Status: Server: Disabled Access: View-Only
View-Only: <input type="button" value="Reset Password"/>	Control: <input type="button" value="Reset Password"/>
<input type="button" value="Back"/>	

VNC Settings

Setting	Description	Default
Server	Enables or disables VNC connection to the terminal.	Disabled
Access ⁽¹⁾	Switch between view-only and control access for the VNC connection to the terminal. View-Only - No interaction allowed. Only the current screen on the terminal is displayed. Control - Interaction allowed.	View-Only
View-Only Password	Resets the current password a user must enter when establishing a VNC connection to the terminal for view-only access. The password is a maximum of seven alphanumeric characters (A...Z, a...z, 0...9).	No password ⁽²⁾
Control Password	Resets the current password a user must enter when establishing a VNC connection to the terminal for control access. The password is a maximum of seven alphanumeric characters (A...Z, a...z, 0...9) and special characters ('_', '\$', '-', and '!'). A minimum of one special character is required for the control access password.	No password ⁽²⁾

⁽¹⁾ It is recommended to enable only the view-only access to the terminal. Enabling control access increases the security risk if the password is compromised.

⁽²⁾ Once a password is set, you can only change it. You cannot clear a password unless you perform a restore operation or return the terminal to the out-of-box Condition.

IMPORTANT: Changing any VNC setting will terminate the current VNC connection to the terminal. For example, if you are connected to the terminal in control access and change the access to view-only, the VNC connection will terminate and the next time you connect to the terminal you will be in view-only access.

IMPORTANT: When you update the terminal firmware, the VNC password and settings will be cleared and reset to their default configuration.

(Continued)

Virtual Network Computing (Continued)

Set the Password for VNC Connection

The default VNC settings (no password) prevents you from establishing a VNC connection to the terminal. You must set a view-only or control access password before you can connect to the terminal with the respective access rights.

Follow these steps to set a password for VNC connection to the terminal.

- 1 Press **Enable/Disable** to enable the VNC server.
- 2 Press **Reset Password** for either **View-Only** or **Control** access.

VNC Settings	
Server: <input type="button" value="Enable / Disable"/>	Status: Server: Disabled
Access: <input type="button" value="View-Only / Control"/>	Access: View-Only
View-Only: <input type="button" value="Reset Password"/>	Control: <input type="button" value="Reset Password"/>
<input type="button" value="Back"/>	

- 3 Type in the desired password using the on-screen keypad, then press **Enter**.

VNC Settings	
New Password: <input type="text"/>	
Confirm Password: <input type="text"/>	
Esc F1 F2 F3 F4 F5 F6 F7 F8 F9 F10 F11 F12 Home End	
` 1 2 3 4 5 6 7 8 9 0 - = ←	
↵ q w e r t y u i o p [] \	
Caps a s d f g h j k l ; ' ←↵	
Shift z x c v b n m , . / ↑	
Ctrl Win Alt ins del ← ↓ →	
<input type="button" value="Back"/>	

IMPORTANT: If you forget the VNC password there is no way to recover it. You can perform the restore terminal operation, or return the terminal to the out-of-box configuration. Doing so will clear the password and also remove all applications, logs, recipes, user-installed font files, objects and graphics.

Alternatively you can update the terminal firmware to clear the VNC settings and reset to their default configuration.

Virtual Network Computing (Continued)

Establish VNC Connection to the Terminal

follow these steps to establish a VNC connection to the terminal. TightVNC Viewer is used for the following examples. Your VNC viewer application may have some difference.

- 1 Launch the VNC Viewer application.**
- 2 Enter the IP address of your terminal and click Connect.**

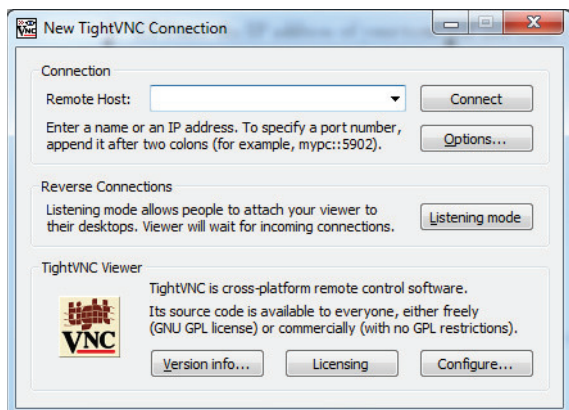

- 3 Depending on the type of access enabled on the terminal (view-only or control), enter the corresponding password for that access type and click OK.**

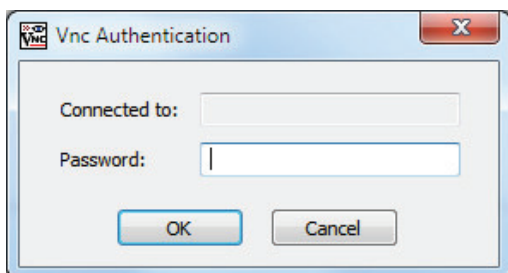

A window opens on your desktop showing the current screen on the terminal.

- 4 To terminate the VNC connection to the terminal, simply close the VNC Viewer application.**

