

USER GUIDE
UGC024/0305

Access Receiver

Models AR2, AR5 and AR10



INTRODUCTION • Purpose of the User Guide • How the guide is organized • Your responsibilities as a user • **ATTENTION:** Read this so no one gets hurt • **DESCRIPTION** • What is the Access Receiver? • Typical applications • How it works • Specifications: Access Receiver • **INSTALLATION** • Unpacking the boxes • Preparing for installation • Mounting the Access Hopper Receiver • Completing the Receiver's Installations • Changing the Receiver's Vacuum Inlet Orientation • Changing the Receiver's Lid Hinge Location • **OPERATION** • Receiver Operation • Types of Feed Tubes • Loader Operation • Operating Modes • Setting Feed Tubes • Sensor Adjustments

Please record your equipment's model and serial number(s) and the date you received it in the spaces provided.

It's a good idea to record the model and serial number(s) of your equipment and the date you received it in the User Guide. Our service department uses this information, along with the manual number, to provide help for the specific equipment you installed.

Please keep this User Guide and all manuals, engineering prints and parts lists together for documentation of your equipment.

Date:

Manual Number: UGC024/0305

Serial Number(s):

Model Number(s):

DISCLAIMER: The Conair Group, Inc., shall not be liable for errors contained in this User Guide or for incidental, consequential damages in connection with the furnishing, performance or use of this information. Conair makes no warranty of any kind with regard to this information, including, but not limited to the implied warranties of merchantability and fitness for a particular purpose.

Table of Contents

1-1 Introduction

Purpose of the user guide	1-2
How the guide is organized	1-2
Using the Access Receiver	1-3
Your responsibilities as a user	1-3
ATTENTION: Read this so no one gets hurt	1-4

2-1 Description

What is the Access Receiver?	2-2
Typical applications	2-2
How it works	2-3
Specifications: Access Receiver	2-5

3-1 Installation

Unpacking the boxes	3-2
Preparing for installation	3-2
Mounting the Access Hopper Receiver	3-7
Mounting the Access Direct Feed Receiver	3-7
Installing Ratio, Line or Inlet Flapper Valves	3-8
Completing the Receiver Installations	3-9
Changing the Receiver's Vacuum Inlet Orientation	3-11
Changing the Receiver's Material Inlet Orientation	3-12
Changing the Receiver's Lid Hinge Location	3-13
Connecting a Remote Demand Sensor	3-15
Connecting a Remote ON/OFF Switch	3-15
Installing a Fill Sensor	3-16
Adding a Pneumatic Solenoid to the terminal box	3-16

4-1 Operation

Receiver Operation	4-2
Types of Feed Tubes	4-3
Sensor Adjustments	4-4

5-1 Maintenance

Screen Filter	5-2
Cleaning the Receiver body.	5-3
Discharge Valve.	5-4
Vacuum Valve	5-4
Ratio and Common Material Line Valve	5-5

6-1 Troubleshooting

Before Beginning.	6-2
A few words of caution	6-2
Conveying Problems	6-3

A Appendix

We're here to help	A-2
How to contact customer service	A-2
Before you call...	A-2
Equipment guarantee	A-3
Performance warranty	A-3
Remote Demand Sensor kit with Demand Selector Switch	A-4
Remote Demand Sensor kit with Demand Selector Switch Wiring Instructions.	A-5
Remote Demand on/off kit	A-6
Remote Demand on/off Wiring Instructions	A-7

Introduction

Purpose of the user guide. 1-2

How the guide is organized. 1-2

Using the Access Receiver 1-3

Your responsibilities as a user. 1-3

ATTENTION:

 Read this so no one gets hurt 1-4

Purpose of the User Guide

This User Guide describes the Conair Access Receiver and explains step-by-step how to install, operate, maintain and repair this equipment.

Before installing this product, please take a few moments to read the User Guide and review the diagrams and safety information in the instruction packet. You also should review manuals covering associated equipment in your system. This review won't take long, and it could save you valuable installation and operating time later.

How the Guide is Organized

Symbols have been used to help organize the User Guide and call your attention to important information regarding safe installation and operation.



Symbols within triangles warn of conditions that could be hazardous to users or could damage equipment. Read and take precautions before proceeding.

- 1** Numbers indicate tasks or steps to be performed by the user.
- ◆ A diamond indicates the equipment's response to an action performed by the user.
- ☐ An open box marks items in a checklist.
- A circle marks items in a list.
- ◆♦ Indicates a tip. A tip is used to provide you with a suggestion that will help you with the maintenance and the operation of this equipment.
-  Indicates a note. A note is used to provide additional information about the steps you are following throughout the manual.

Using the Access Receiver

Each Access Receiver is designed to work within a central vacuum system consisting of:

- Vacuum Receiver
- Vacuum Pump
- Dust Collector
- Central Loading Control(s)
- Central Vacuum Tubing

The role of the receiver in these systems is to provide a receiving device for plastic material(s) that are conveyed by the energy and control provided by the other components.

Separate instructions are provided for these devices and should be referred to as needed to fully understand the operation of the entire system.

Your Responsibility as a User

You must be familiar with all safety procedures concerning installation, operation and maintenance of this equipment. Responsible safety procedures include:

- Thorough review of this User Guide, paying particular attention to hazard warnings, appendices and related diagrams.
- Thorough review of the equipment itself, with careful attention to voltage sources, intended use and warning labels.
- Thorough review of instruction manuals for associated equipment.
- Step-by-step adherence to instructions outlined in this User Guide.

ATTENTION:

Read this so no one gets hurt

We design equipment with the user's safety in mind. You can avoid the potential hazards identified on this machine by following the procedures outlined below and elsewhere in the User Guide.



WARNING: Improper installation, operation, or servicing may result in equipment damage or personal injury.

This equipment should be installed, adjusted, and serviced by qualified technical personnel who are familiar with the construction, operation, and potential hazards of this type of machine.

All wiring, disconnects, and fuses should be installed by qualified electrical technicians in accordance with electrical codes in your region. Always maintain a safe ground. Do not operate the equipment at power levels other than what is specified on the machine serial tag and data plate.



WARNING: Voltage hazard

This equipment is powered by a control voltage, as specified on the machine serial tag and data plate. See separate loading control manual.

A properly sized conductive ground wire from the incoming control wiring must be connected to the ground terminal inside the electrical enclosure. Improper grounding can result in severe personal injury and erratic machine operation.

Always disconnect and lock out the incoming main power and control sources before opening the electrical enclosure or performing non-standard operating procedures, such as routine maintenance. Only qualified personnel should perform troubleshooting procedures that require access to the electrical enclosure while power is on.

Description

What is the Access Receiver?	2-2
Typical applications	2-2
How it Works	2-3
Specifications: Access Receiver	2-5

What is the Access Receiver?

The Access model vacuum receiver is a plastic material transfer device designed to vacuum convey raw plastic material pellets and/or regrind. It incorporates a vacuum sequence valve to direct the vacuum energy necessary for the material transfer process, and a screw filter to separate conveyed material from the conveying air stream. Compressed air is required for the vacuum sequence valve and some optional functions, like Ratio loading.

Typical Applications

Access vacuum receivers are typically used in two main ways; Hopper loading and Direct feed.

Hopper Loading: The receiver is mounted directly above whatever vessel needs to be filled and to be kept full. The Access vacuum chamber is filled by vacuum from a remote vacuum pump and then a discharge flapper at the bottom opens, by gravity at the conclusion of loading to release the loaded material into the receiving vessel. A demand level switch, triggered by the position of the discharge flapper indicates the need for more loading or not.

Direct Feed: The receiver is mounted to a glass or metal hopper that is mounted to the throat of a plastic processing machine (IE: injection molder or extruder). A sensor on the hopper indicates the need for material. Material gravity flows out of the hopper and into the processing machine via the drain hole in the bottom.

The Access receiver may also be used to unload vessels, like granulators, gaylords or barrels.

How it Works

The loading cycle:

A demand for material below the receiver is created by either a reed-type switch that is magnetically triggered by the position of the discharge flapper on the bottom of the hopper loading model or by a sensor located elsewhere. This demand signal starts the loading cycle and all portions of the loading cycle. All other functions are governed by the central loading control, which governs all aspects of the loader's operation.

The demand signal starts the vacuum motor and allows the loader's vacuum chamber to create a negative draw on the material inlet line. This vacuum creates a flow of air that starts in the material inlet tube and allows plastic material to travel in the tube, with the air, into the receiver. Once inside the receiver, the air is drawn through the vacuum sequencing valve after it passes through a round screen filter located between the receiver body and the vacuum valve. This screen keeps the plastic material in the receiver's vacuum chamber but allows the air and dust to pass through. This filtration not only keeps the material in the receiver, but allows dust and fines to pass through the vacuum system back to a centralized dust collection device.

The unloading cycle:

Once the loading cycle concludes, the vacuum sequencing valve closes and the receiver enters the unloading portion of the cycle. While there is no vacuum pull on the receiver from the vacuum, the material in the receiver is allowed to drop from the bottom of the receiver, into the receiving vessel the receiver is mounted upon. If the receiver is a direct feed type, then the material simply flows down into the processing machine.



How It Works (continued)

The ratio loading cycle (optional):

A popular option for the Access receiver is a ratio valve to allow the user to use the Access receiver for conveying two materials, virgin and regrind. This option is typically used to reload granulated material from a granulator or vessel into a processing machine while virgin material is being loaded. This simple valve device works during the loading cycle and is controlled by the central loader control. For Conair control, loading times for the two materials may be independently set so that approximate portions of each material can be transferred during loading. In addition, each of these portions may be programmed to occur several times during the loading cycle, if desired, so that there is a layering of the materials in the receiver's vacuum chamber, encouraging a mixture of materials as they flow out of the receiver at the conclusion of loading. As the vacuum loading cycle operates, each inlet of the ratio valve alternately opens and closes in response to the control settings. As each inlet opens, vacuum flows through that line and allows virgin or regrind to flow to the receiver. Then the other inlet opens, allowing that line to draw material through it. This sequence occurs until the receiver's load time setting expires.

Specifications

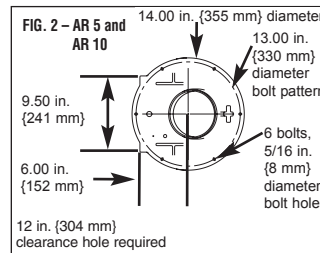
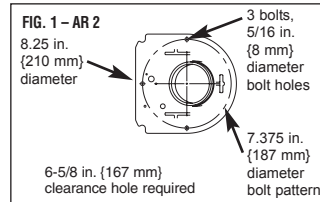
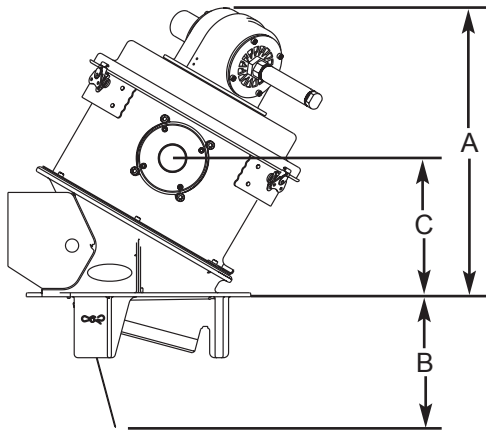

Receiver model	AR 2	AR 5	AR 10
Receiver volume ft ³ {liters}	0.2 {5.6}	0.5 {14.15}	1.0 {28.31}
Loader body diameter inches {mm}	8 {203}	12 {304}	12 {304}
Material/vacuum line	1.5-2 {38-51}	1.5-2 {38-51}	1.5-2 {38-51}
Filter type	20 mesh stainless steel disc		
Available voltages {outputs}	120 VAC, 24 VAC and 24 VDC		
Compressed air requirement	Intermittent duty: 1ft ³ /min. @ 80 psi {28.3 liters/min. @ 5.51 bars} NPT fitting: 3/8 in.		
Discharge type	Gravity flapper or Positive Discharge		
Demand sensor	integrated reed switch/remote capacitive sensor (optional)		
Dimensions inches {mm}			
A - Height above mounting plate	18.17 {461.52}	18.04 {458.22}	23.75 {603.25}
B - Depth below mounting plate	5.12 {130.05}	8.12 {206.25}	8.12 {206.25}
with positive discharge	10 {254}	16 {406}	16 {406}
C - Height to center of material inlet	8.77 {222.76}	8.64 {219.46}	14.34 {364.23}
Mounting details	Fig. 1	Fig. 2	Fig. 2
Installed weight lb {kg}	21{9.53}	39.5 {17.92}	44 {19.95}
Shipping weight lb {kg}	35 {15.9}	50 {22.7}	70 {31.8}

SPECIFICATION NOTES

Specifications can change without notice. Contact your Conair representative for the most current information.

Installation

Unpacking the boxes	3-2
Preparing for installation	3-2
Mounting the Access Hopper Receiver.	3-7
Mounting the Access Direct Feed Receiver.	3-7
Installing Ratio, Line or Inlet Flapper Valves	3-8
Completing the Receiver's Installation	3-9
Changing the Receiver's Vacuum	
Inlet Orientation	3-11
Changing the Receiver's Material	
Inlet Orientation	3-12
Changing the Receiver's Lid Hinge Location	3-13
Connecting a Remote Demand Sensor	3-15
Connecting a Remote On/Off Switch	3-15
Installing a Fill Sensor	3-16
Adding a Pneumatic Solenoid to the	
Terminal Box	3-16

Unpacking the Boxes

The Access self-contained vacuum loader comes in one to 3 boxes, depending upon the model and options selected. The loader will be shipped in one large box and accessories like feed tubes and ratio valves will be shipped in their own, smaller boxes.

 **Note:** Your particular loader may be packaged in with other equipment crates or boxes or may also have equipment packaged in with it, to conserve shipping space.

- 1 Carefully remove the loader and other components** from their boxes. Do not use wires or hoses as handles to lift heavy components. Once removed from the box, the loader may be set on a firm, flat surface with the motor towards the top. Note that the loader's upper portion is angled for easy access once in operation, but its three-legged, cast base may be safely set on a flat surface, as long as the discharge flapper valve is not open.
- 2 Remove all tape and other packing materials** from the loader and accessories. Take special note of tape that typically holds the discharge flapper closed. The loader will not work with this tape in place and it should be removed.
- 3 Carefully inspect all components** to make sure no damage occurred during shipping, and that you have all the necessary hardware.
- 4 Take a moment to record serial numbers** and electrical power specifications in the blanks provided on the back of the the User Guide's title page. The information will be helpful if you ever need service or parts.

Preparing for Installation

 **WARNING:** You are responsible for the structural integrity of this installation.

Hopper-mounted Access receivers may be installed on any vessel with a flat top surface as long as the lid and vessel are strong enough to support the weight of the receiver. Have mounting provisions such as bolt holes or hold down clamps (*see Section 2, "Specifications"*). Direct Feed Access receivers are designed to mount directly to the throat of a processing machine and the base of the throat mounted assembly may be centered and match-drilled to the bolt hole pattern of the processing machine throat.

- 1 Prepare the electrical connection.** Access receivers operate in a central vacuum conveying system and need to be connected to the control system that operates the loaders and vacuum pump. There are two methods of connection possible; multi-pin connector and "hard wiring". Both connections are made on the side of the black terminal box, on the non-operator side of the receiver.

Multi-Pin Connections

Multi-pin connectors are used for Conair Selectronic control systems. (Refer to the appropriate control system manual for additional installation instructions) Your Access receiver is likely to be shipped with the appropriate multi-pin connector if the receiver has been ordered to operate with a Selectronic control then nothing further needs to be done.

If using a Control other than a Selectronic an identical multi-pin connector may also be supplied on your Access receiver. In this case, your receiver wiring is complete, but a mating connector must be provided that will connect the Access receiver to the central control via the multi-pin connector set. If the receiver is provided with a connector, then the mating connector is likely to be included with the shipment. Wiring details for this connector are a part of the central control wiring schematic, which are included in the separate control system manual.

Hard Wiring

Access receivers with an open hole in the side of the terminal box must be hard wired to the central control cable in order to operate. The hole is sized to accommodate a typical strain relief fitting for the size of multi-conductor cable commonly used in loading control systems from Conair. The hole may be enlarged in order to accommodate a different size, if needed.

Coordinate the cable connections that are required with the functions of your Access receiver. Fewer features require fewer conductors, but Conair commonly provides cable that includes enough conductors for all possible functions. When using Conair supplied cable, connections are simpler, without the need for interpretation of functions, cable color code and number of conductors. Use of other cables may not coordinate directly and will require interpretation.



NOTE: A multi-pin connector may also be added to any Access receiver if desired. Contact Conair sales or parts department to purchase a retrofit connector and cable set for your receiver. Instructions for installation are provided with the connector/cable set.

Preparing for Installation (continued)

Receiver functions and color coding are included inside the Access terminal box. The color coding matches Conair-specified cable. If non-Conair cable is used, a substitute chart must be created to coordinate loader functions to each conductor color. Terminations are provided via spring loaded terminals that may be opened by pressing on the adjacent tab. Approximately 3/8" strip is required on each conductor. Some Access receivers include a very compact terminal box and terminations are easier to perform if they are made in advance of the cable being secured to the cord grip, or before the cord grip is installed in the enclosure. The cable itself will not block the terminals that you will be connecting to. To utilize this technique, separate the conductors, leaving an ample length of individual wires for your terminations. Make all connections, and then push the cable sheathing into the cord grip and tighten the cord grip's grasp on the cable.



CAUTION: Be sure to wear safety glasses to guard against air-borne material particles if compressed air cleaning is employed. Be sure that the compressed air being employed is completely dry and will not add moisture to the filter media. If moisture is added, the collected fines will probably solidify into clumps that will be very difficult to remove. If moisture is accidentally introduced, set the filter aside and allow it to thoroughly air dry before vacuuming at a later time, or replace it with a new filter.

2 Prepare the compressed air supply. An air supply line must be plumbed to the solenoid located in the terminal box of the receiver and a quick disconnect fitting is recommended for easy service. A 1/4" NPT female inlet is provided. If the air supply is not clean and dry, filtering devices must also be installed to prevent solenoids from sticking. Moisture traps and other air cleaning devices are best mounted away from the receiver, but within easy service reach.

3 Determine location of control. The Access receiver's Selectronic control may remain mounted to the loader or be remote mounted to a convenient location. When mounted on the loader, no further work is required. If mounted remotely, a quick-disconnect, remote control cable between the control and the loader must be installed and may have been shipped with the receiver. If not, one is available from the Conair Parts Department. Assure that your desired control location is within the length of the remote control cable and the control can now be removed from the loader in preparation for being mounted in its remote location by removing the mounting bolts at the base of the loader's mounting bracket and unplugging the control cable from the terminal box of the loader. The control is mounted on a tiltable bracket and may be swung up to facilitate removal of the bracket or the control may be removed from the mounting bracket by removing the two side bolts at the hinge point. Once removed, replace the bolts in the flange of the receiver body.

Preparing for Installation (continued)

- 4 Determine the orientation of the receiver.** The Access receiver provides superior accessibility for service and should be oriented for easiest service and access to the control. The material inlet and even the lid hinge may be relocated as required, once orientation is determined. Assure that enough room above and to the side of the loader is available for the hinged lid to open.
- 5 Prepare the mounting surface; Hopper loaders.** For hopper loading receivers, the Access receiver discharge will fit down through an opening in the receiving hopper's lid and be held in place with either bolts that pass through match-drilled holes or hold-down clamps that are typically supplied on the top of Conair vessels like drying hoppers or blenders bins. *See Section 3, "Specifications"* for the size of clearance hole required and/or bolt patterns for your model of receiver. An adapter ring, available from Conair, may be required to reduce the size of an oversized hole to match the specific size of the receiver being installed.
- 6 Prepare the mounting surface; Direct feed receivers.** For Direct feed receivers, assure that the processing machine throat is large enough to provide a suitable mounting surface for the receiver and its sight glass. Measure the mounting bolt locations on the machine throat and assure that a suitable location in the base of the receiver may be drilled. Be sure the material passage hole in the bottom lines up with the processing machine throat and that no ledges will be created between the receiver assembly and the machine throat. If ledges will be present, an adapter plate with a tapered material opening may be required. An adapter plate may also facilitate the location of mounting holes if there is a mis-match between the base of the sight glass chamber and the machine throat.
- 7 Determine the location of conveying line(s).** Material conveying lines should be as straight and as short as possible. Multiple bends or loops in the hose or material conveying tubing should be avoided. If the Access receiver material inlet does not accommodate the best path for the material line(s), the inlet may be moved and is described in *Section 3, "Changing the Receiver's Material Inlet Orientation"*.

Preparing for Installation (continued)

 **NOTE:** If your mounting surface does not match the standard bolt patterns available, you will need an adapter. You can make an adapter using the dimensions provided or purchase one from Conair.

8 Determine orientation of ratio, line or inlet flapper valve (optional). If a ratio valve is included with the loader, note the incoming material lines (virgin and regrind) will be at right angles to the material inlet of the loader. Note that the inlets of the ratio valve may be oriented on opposite sides or the same side of the valve assembly, depending upon your needs. *See Section 3, “Installing Ratio, Line or Inlet Flapper Valve”.*

9 Determine the orientation of the vacuum valve

Note the hose connection on the vacuum sequencing valve on the lid of the receiver and the hose is routed. The receiver has been shipped with the hose orientation optimized for the hinged lid's opening and you are likely to find it suitable for your installation. But if another orientation might be better for your receiver's location and the location of your vacuum connection, then the vacuum sequencing valve may be rotated to any of four positions. *See Section 3, “Changing the Receiver's Vacuum Valve Orientation”* for more information on changing the vacuum sequencing valve's orientation.

10 Connecting Material Valve Compressed Air Lines for Access receivers that have material valves installed. The compressed air lines must be connected to the valve in the proper orientation for operation. Typically, the valve's compressed air solenoid is already located in the Access terminal box and is already wired. All that remains is connecting the protruding compressed air lines to the cylinder(s) on the valve. To connect the air lines, simply match the color coded air lines to the same color on the valve's cylinders.

Mounting the Access Hopper Receiver



WARNING: You are responsible for the structural integrity of this installation.

- 1 Safely lift the Access receiver to the lid of the vessel.** Assure that the Access receiver lid is closed and clamped securely.
- 2 Lift the receiver into place,** carefully place the three legged base down into the clearance hole of the vessel lid. Rotate and orient as desired. The receiver body's "lean" should be in the direction of future service like screen cleaning and material change clean-outs and the control face (if included) should be facing the same direction.
- 3 Secure the Access receiver to the lid of the hopper.** If clamps are provided, swing them into position over the edge of the loader's flange and tighten them. If nuts and bolts will be used, pass them through the vessel lid and through the mating holes in the mounting flange of the loader and secure them with lock-washers and nuts after applying thread-locking compound to prevent loss due to vibration. If possible, nuts welded to the underside of the vessel lid are preferred, to prevent any possibility of fastening hardware loosening and being lost into the vessel.

Mounting the Access Direct Feed Receiver

- 1 Match drill the base of the sight glass chamber.** Carefully measure the throat of the processing machine and match drill the base of the Access receiver's glass or metal hopper, assuring the large center hole of the casting lines up with the feed throat opening of the processing machine. If the base will not allow passage of mounting bolts that line up with the processing machine throat bolts, an adapter plate may be required. If the material flow hole in the base of the casting is larger than the processing machine throat, creating a ledge, an adapter plate with a tapered material flow hole may be required. To facilitate use of a drill press or machining center, the base of glass hoppers may be unbolted from the glass.

Mounting the Access Direct Feed Receiver (continued)

- 2 Mount the direct feed hopper to the processing machine throat.** Once the base is drilled, it may be mounted to the machine throat, for complete re-assembly once mounted. Mating surfaces between the hopper, the adapter plate (if included) and the machine throat may be gasketed to minimize vacuum air leaks that can occur during vacuum conveying to the receiver, but gasketing is not essential, since the Access receiver is equipped with its own discharge flapper to isolate vacuum conveying air to the loading chamber of the loader.
- 3 Orient the receiver on the hopper.** The receiver's portion of the direct feed assembly may be rotated to orient the receiver in the best position for service and tubing routing.

Installing Ratio, Line or Inlet Flapper Valves

For Access receivers that are supplied with ratio line, or inlet flapper valves, the valve may be shipped loose and needs to be mounted to the Access material inlet. For this purpose, the material inlet of the receiver is provided without an inlet stub. When the valve is installed, it will provide the material inlet line(s) accordingly. To install the valve onto the inlet casting:

- 1 Assure that the Access receiver is oriented as desired** on the bin that you will be loading and visually check the positioning of the valve on the inlet casting. Note that the material inlet(s) will be 90 degrees from the orientation of the inlet of the receiver. If this orientation will not be appropriate for your installation, consider reconfiguring the material inlet to another direction as described in *Section 3, "Changing the Receiver's Material Inlet Orientation"*. If orientation is satisfactory, proceed to step two.

Installing Ratio, Line or Inlet Flapper Valves (continued)

- 2 As you visually check the orientation of the installed valve**, note that the valve itself may be re-oriented to allow the material to enter the valve as supplied, or 180 degrees from its supplied orientation. In the case of a ratio valve, the dual inlets may actually be re-oriented to enter from opposite directions, if desired. (See Section 3, “Changing the Receiver’s Material Inlet Orientation”) for instructions on changing the inlet orientation(s).
- 3 The valve casting is supplied with a mounting flange that mates with the inlet casting of the receiver.** Note that the inlet casting contains eight holes to allow mounting the valve in two different orientations, depending upon which side of the receiver the inlet casting is located. Select the set of mounting holes that position the valve body upright, with the clean out cover on top horizontally.
- 4 Use the accompanying bolts to secure the valve casting to the inlet casting** with the included gasket in between the two mating surfaces.
- 5 See Section 3, “Preparing for Installation” for connecting material valve compressed air lines for details on compressed air hookups.**

Completing the Receiver Installations

- 1 Install the vacuum hose:** The flex hose from the central vacuum header must be connected to the vacuum sequencing valve on the Access receiver lid. Provide enough slack in the hose to allow the lid to be easily opened for service and if necessary, rotate the valve to another orientation to provide a suitable route for the vacuum hose.
- 2 Install the conveying line; single material:** Connect the material conveying tubing to the receiver by clamping one end of the flex hose around the inlet nipple of the loader. Route the hose carefully avoiding bends, loops, or droops and cut the hose to length and connect the included feed tube into the other end. Secure both connections with the included hose clamps. If orientation of the inlet needs to be changed, (See Section 3, “Changing the Receiver’s Material Inlet Orientation”).

Completing the Receiver Installations (continued)



WARNING: You are responsible for the structural integrity of this installation.

3 Install the conveying lines; ratio loader: If a ratio valve is included, it must be installed on the material inlet port of the loader with the provided bolts. Bolt the valve so that it is positioned as upright as possible with the material inlets (virgin and regrind) positioned as horizontal as possible. Note that the top section of the ratio valve may be easily removed and oriented to allow for the incoming materials to come from the same direction or two different directions. If orientation of the inlet needs to be changed to allow for better routing of the lines coming into the ratio valve, (*See Section 3, “Changing the Receiver’s Material Inlet Orientation”*). Once the valve is installed on the loader and orientation of the incoming lines are established, conveying tubing may be connected to the valve and secured with hose clamps. The other ends of the tubing may be connected to their appropriate feed tubes and secured with hose clamps, assuring that the tubing is routed and cut to length to take the most direct and shortest path. Be sure to connect the right tube to the right material source as marked on the valve inlets: V=Virgin, R=Regrind.

4 Connect compressed air to the receiver: The Access receiver requires compressed air for the vacuum sequencing valve function, plus options, like ratio loading. The compressed air supply line should be connected into the 1/4" NPT female fitting provide in the side of the terminal box. A quick disconnect fitting (that does not restrict air flow) is recommended.



CAUTION: Be sure to wear safety glasses to guard against air-borne material particles if compressed air cleaning is employed. Be sure that the compressed air being employed is completely dry and will not add moisture to the filter media. If moisture is added, the collected fines will probably solidify into clumps that will be very difficult to remove. If moisture is accidentally introduced, set the filter aside and allow it to thoroughly air dry before vacuuming at a later time, or replace it with a new filter.

Changing the Receiver's Vacuum Valve Orientation

To change the orientation of the vacuum sequencing valve on the lid of the receiver,

- 1 Disconnect the control power and the air supply to the receiver.** If the receiver has been in operation and is currently connected with hose to the vacuum header, the vacuum hose may remain connected and the following work may be done without de-energizing the central vacuum system.

Be sure that the new, desired vacuum valve position will not pinch, stretch or be blocked by the vacuum hose when the lid is either closed or open.

- 2 Remove the four bolts that hold the sequencing valve to the lid of the receiver,**
- 3 Remove the valve body and secure the gasket** between the valve body and the lid to prevent loss.
- 4 Re-orient the valve body to the desired location,** re-position the gasket between the body and the lid and re-install the four bolts. Assure that the compressed air line is not strained in the new position and if so, provide a longer length air line as needed.
- 5 Tighten the four bolts evenly.**

Changing the Receiver's Material Inlet Orientation

Access receivers are shipped with the material inlet in a specific orientation. This orientation may be easily changed as needed so that your material supply line routing is optimized for your specific needs.

 **Note:** If your Access receiver includes a ratio, line or inlet flapper valve on its inlet, then be sure to select a location for the material inlet that allows the inlet to be oriented horizontally, to allow for smooth operation of the ratio, line or flapper valve. A crooked valve will not operate satisfactorily and can create plugs in the material line.

- 1 Prepare receiver for conversion by disconnecting the flex hose on the inlet.**
- 2 Remove the lid of the receiver** by disconnecting the main compressed air inlet line and removing the compressed air hose from the lid cylinder.
- 3 Unclamp the lid and pull the hinge pin**, allowing the lid to be removed from the receiver body, remain connected to the central vacuum line. Other receivers in the system can still operate and the vacuum pump does not need to be shut down. Another alternative to lid removal is complete removal of the loader from the system and plugging of the vacuum line.
- 4 Remove the 6 screws** from around the perimeter base of the Access receiver body cylinder.
- 5 Once removed, the body of the receiver may be freely rotated to an alternate set of holes**, allowing the material inlet to be placed in the best position for your installation.
- 6 Replace all bolts and tighten.** Re-assemble all other parts as needed to resume operation.

Changing the Receiver's Lid Hinge Location

Access receivers are equipped with lid hinges that have been installed in a location that permits optimum access to the receiver body by allowing the lid to be hinged up and out of the way during cleaning/service. In some cases, this hinged position may not be ideal due to obstructions. Access lids may be hinged from any of the three clamp mounts that are located around the perimeter of the receiver's body. To change the hinge position:

- 1 Remove the lid from the receiver body** by disconnecting power, unclamping all lid clamps and disconnecting all hose and wires that connect the receiver body to the lid.
- 2 Determine the new location for the lid hinge** and remove the hold down clamp currently in that position. Do not discard the clamp nor its screws.
- 3 Remove the hinge mechanism from the receiver body** and re-install the hinge mechanism in its new position, formerly occupied by the lid clamp.
- 4 Install the clamp**, removed in step 2 to the clamp mount formerly occupied by the hinge mechanism.
- 5 Reinstall the lid onto the new hinge position**, test the hinge action briefly and then modify cable and hose paths for the new hinge location. Doublecheck that the hinge does not trap or pinch hoses or wires.

Changing the Receiver's Lid Hinge Location *(continued)*

- 5** Reinstall lid onto new hinge position, test hinge action briefly and then modify cable and hose paths for the new hinge location. Doublecheck that the hinge does not trap or pinch hoses or wires.
- 6** Adjust lid, clamps and hinge to assure that vacuum sealing is retained and that the lid opens and closes easily and that the lid locks reliably when it is in the up position.



Connecting a Remote Demand Sensor option

A remote demand sensor option allows the user to remote the “demand” signal position of a receiver to an alternate location VS using the integrated demand sensor (reed switch) that is triggered by the receiver’s discharge flapper valve. This is usefull on drying hoppers working to less than full capacity or blender bins that do not need to be filled up completely. If this option is added by the user, the kit that accompanies the sensor will include detailed installation instructions that should be followed and will consist of:

1. Rewiring the existing demand reed switch to work with the optional remote demand sensor circuit.
2. Installation of a toggle switch on the terminal box to allow easy selection of either the integrated demand switch or the newly installed remote demand sensor.
3. Mounting and plugging in the remote demand sensor.

(For more details on Connecting a Remote Demand Sensor, see the separate instructions that are provided as well as the Appendix.)

Connecting a Remote On/Off Switch option

The use of a remote on/off switch option for a receiver allows the user to interrupt the operation of the receiver with the flip of a switch to pause the loading function or prevent the receiver from operating during maintenance, etc. When this option is added by the user, the on/off switch kit includes instructions for wiring and installation and consists of:

1. Mounting the remote on/off switch box in a convenient, yet safe location and routing the included cable to the receiver terminal box
2. Rewiring the demand input circuit to include the new switch so that a demand signal is not delivered to the the loading control unless the remote on/off switch is in the “on” position and the demand sensor or reed switch are indicating the need to the start loading.

(For more details on Connecting a Remote on/off switch, see the separate instructions that are provided as well as the Appendix.)

Installing a Fill Sensor option

A fill sensor can add valuable functions to a receiver's operation by immediately terminating a load cycle once the receiver is full, saving energy and preventing overfilling. In addition, the loader control will provide an alarm signal if the receiver hopper is NOT filled to the sensor, providing a usefull early warning to material loading issues.

The fill sensor is installed by drilling a hole in the receiver side wall, adjacent to the material inlet. The size and specific location of this hole is detailed in instructions that accompany the fill sensor. The sensor is then secured on both sides by plastic nuts that hold the sensor in place and an “O” ring is included to maintain a vacuum seal around the sensor's body.

The sensor is wired into the terminal box using an included cord grip, through one of the existing (plugged) holes in the top of the terminal box. Inside of the terminal box, the sensor is connected to terminals labeled #7 (Fill Sensor) and #10 (Sensor Common). Be sure to enable the fill sensor function within the loading control, according to its detailed instructions. Be sure that the control being used is prepared to operate with a fill sensor. In some cases, this operation requires the addition of programming or additional circuitry, to allow the fill sensor to operate.

The fill sensor must then be adjusted to properly sense the material being loaded by the procedure outlined in *Section 4, “Sensor Adjustments”*.

Adding a Pneumatic Solenoid to the Terminal Box

Gang-style pneumatic solenoids are housed in a protective terminal box on the back of the Access receiver and are supplied, plumbed and wired as originally ordered. In the event that an additional solenoid needs to be added, the solenoid may be added as follows:

- 1 Disconnect air and electric to the receiver.** It is recommended that the receiver be moved to a well lit work area for this conversion.
- 2 Remove the two screws from each side of the terminal box** and open the box by tilting the top edge down and exposing the inside where the terminal block may be seen.

Adding a Pneumatic Solenoid to the Terminal Box (continued)

- 3** Assure that the new solenoid matches the voltage of the receiver. Voltages are marked on the coil section of the solenoid and must match voltage and type (AC or DC) of the receiver exactly.
- 4** Fasten the new solenoid directly to the existing solenoid with the supplied hardware, assuring that all fasteners are tightened to eliminate potential leaks. The new solenoid will be installed in the same orientation as the existing solenoid. Reconnect the blank end plate to the new solenoid.
- 5** The ganged solenoids may now be re-installed in the terminal box using the same mounting screws. Hole plugs will need to be removed from the next set of screw holes to allow the screws to be inserted. The original solenoid should end up in the same location, with the new solenoid added to the terminal block side of it. Remove the larger hole plug from the top of the terminal box to expose the red manual operator button on top of the solenoid coil.
- 6** Wiring of the solenoid will include an understanding of the function of the new solenoid. The wires can be stripped and inserted into the terminal strip according to the included terminal strip list. One wire will be terminated into a “neutra” terminal and the other into the appropriate function terminal, IE: “ratio”.
- 7** The hosing of the solenoid will be dependent upon its function and includes two hoses, connected to the appropriate pneumatic cylinder, routed through the square hole in the top of the terminal box. The hose stemming from the fitting marked “2” will supply air when the solenoid is energized. Fitting “1” supplies air when the solenoid is de-energized.

8 Connections to Pneumatic Cylinders are as follows:

	Hose from 1	Hose from 2
Line Valve	End	Base
Ratio Valve	“T” on top cylinder	“T” on bottom cylinder
Positive Discharge Valve	Base	End

Operation

Receiver Operation 4-2

Types of Feed Tubes 4-3

Sensor Adjustments 4-4

Receiver Operation

Loading is accomplished by inserting the feed tube(s) into the material supply, turning on the control, allowing material to flow into the receiver and adjusting the virgin (and/or regrind) load time. The flow of material may be optimized by adjusting the feed tube's "air to material" settings covered in the *Section 4, "Feed Tube Settings"*.

Start of the loading function is triggered by the demand switch, integrated into the gravity discharge valve on the bottom of the receiver (or provided as a separate switch). On a "hopper loader", when the flapper on the loader is closed by its own counterweight, it is an indication that the receiver is free of material and must provide more material by loading. The standard demand switch is a "reed" type that magnetically interacts with a small magnet, located on the flapper. As the flapper closes and the magnet gets close to the reed switch, the switch closes, providing a demand signal to the loader control. From that point, the loader control's timed functions take over, providing a complete load cycle with vacuum unloading, etc. resulting in material dumping from the loader into the receiving vessel below.

After discharging material into the receiving vessel below the receiver, the cycle may repeat or the discharge flapper may be held open with the material that was discharged from the loader. If the flapper closes, the cycle will repeat. If the flapper is held open by the material, it is an indication that there is no need for another load cycle and the receiver will wait until the material level falls, the flapper closes, the magnet comes close to the reed switch and triggers another load cycle.

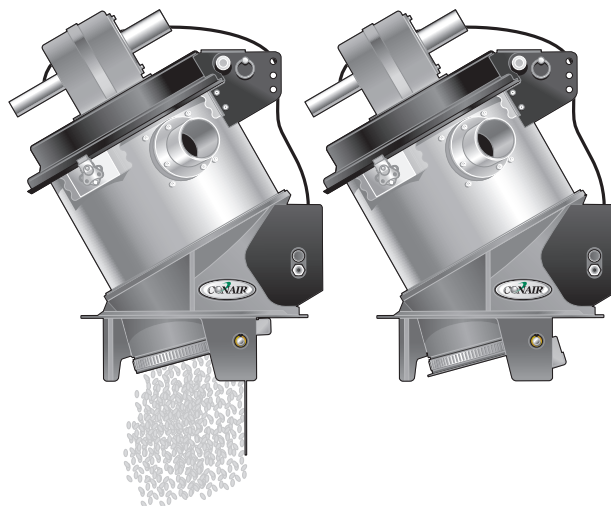

Full

Demand

Types of Feed Tubes

Feed tubes may be provided in a variety of styles made to match the needs for your production. Whether they are horizontal types like distribution boxes (take off boxes) or horizontal bin tubes, or vertical types like wands that are made to be hand inserted into material bins, they need to be adjusted for their air-to-material ratio. Conair provides vertical feed tubes that provide a fixed amount of material entry with adjustments for air flow and horizontal types with fixed air flow and adjustments for regulating material entry.

Vertical Feed Tube Adjustments

Smooth material flow is controlled by opening or closing the holes at the top of the feed tube, either with the flex hose connected to the feed tube or with strong tape (duct tape is commonly used).

Start by inserting the feed tube into the supply of material and observing its conveying action. If the material surges (“gulps” as it is conveyed), clear the line by lifting the feed tube out of the material supply and allowing the line to clear. Then cover holes on the feed tube and retest until the material conveys smoothly.

Covering all holes conveys the maximum amount of material with minimal air, producing the highest volume of material flow but at the slowest possible conveying speed (a low air-to-material ratio). This can make conveying over longer distances or through bends more difficult. With holes uncovered, a ‘thinner’ flow of material is achieved and the greatest conveying speeds are realized. This is a high air to material ratio and can create undesirable material fracturing in the loader, “angle hair” in the conveying lines and material dust.

Test several cycles to achieve the desired results by covering or uncovering feed tube holes. Once conveying is fine tuned, the feed tube should be twisted in its conveying hose to place the open feed tube holes up, so that material cannot fall out of the holes when conveying stops.

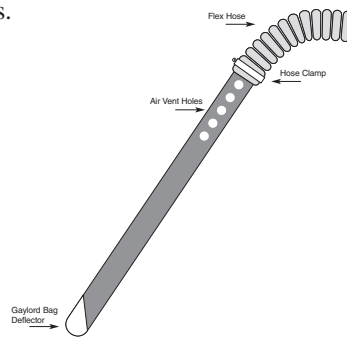

Horizontal Feed Tube Adjustments

Start by loosening the thumb screw next to the adjustable air inlet tube and push it all the way in, closing off material flow and allowing 100% air to flow through to the loader. Over the course of several cycles, pull the air tube out slowly until optimum conveying is achieved with minimal surging (gulping). If surging does occur, clear the conveying line by pushing the air inlet tube all the way in until the line centers and trial and error settings may be attempted again.

Once optimum settings are achieved, the air inlet position may be locked into position with the thumb screw.



NOTE: As described in “Types of Feed Tubes”, different types of feed tubes feed material mixed with air in different ways. Conair horizontal feed tubes (distribution boxes, etc.) provide adjustments for material flow with a fixed amount of conveying air for optimum material flow. Competitive units may not work in the same manner.

Sensor Adjustments

Capacitive Level Sensors use their own on-board electronics to sense the presence or absence of material located in front of the flat face of their cylindrical bodies and trigger loader control functions as a result. Typical uses are as fill sensors, to indicate a full loader condition and terminate the loading cycle and demand sensors, which start loading by indicating the absence of material in a bin or sight glass. Before use, the control must be set to accept and operate with the specific sensor model being used and the sensor must be set to detect the material being conveyed and to ignore the sensor’s surroundings (metal, sight glasses, etc.) as well as set to ignore material dust that may collect on the sensor face. In some cases, sensors must be readjusted for each new material being conveyed.

General Sensor Sensitivity Adjustments

Every sensor is equipped with a multi-turn screwdriver adjustment, located within a small hole on the corded end of the sensor body. Most are also equipped with an indicator light to signal response by the sensor. With the sensor in the correct position for operation, (See Section 4, “Demand Sensors”) the adjustment screw can be rotated clockwise for more sensitivity and counter-clockwise for less sensitivity. The small signal light on the sensor illuminates when the sensor does not “see” material. As a guide, the light will go off, when the sensor detects something in front of its face. It should be adjusted to ignore glass and adjacent surfaces and fine tuned to respond only to the presence of material. This may require several back and forth adjustments to optimize the setting.

Demand Sensors

Demand sensors are utilized in two different ways: In direct contact with material or through sight glass.

When coming in direct contact with material, it is recommended that the sensor be initially adjusted for sensitivity and then re-adjusted, once the sensor becomes coated with typical material fines, common to plastics conveying.

Sensors that sense material through glass or plastic windows must be adjusted to “ignore” the window and sense only the material on the other side. These adjustments must be made with the material to be conveyed, so it suggests that they are made during normal operation. Furthermore, the sight glasses may become coated with a certain build-up of plastic dust (from static electricity attraction, etc.) and the sensor should be adjusted (and/or re-adjusted) to ignore this condition. Sensors that are mounted in movable brackets that allow different levels to be set must maintain the same distance setting from the sight glass to assure consistent operation, or be reset for sensitivity. Optimum distance from sight glass for a sensor is the thickness of a piece of paper. This setting permits the closest possible contact with the glass or window, yet is back just enough to be isolated from heat variations that could effect sensor operations.

Fill Sensors

Fill sensors are installed right in the loader body and come in direct contact with material, as it is being loaded. If set correctly, the time the material contacts the sensor is brief, since loading is terminated by the sensor and unloading usually occurs immediately afterwards. If possible and practical, the receiver’s unload function may be interrupted by holding the discharge valve closed, long enough to set the sensor’s sensitivity. If not possible, trial and error settings may be made during repeated loads to set the sensor to terminate the loading cycle. As with other sensor adjustments, it is recommended to check the setting after the receiver as operated for a period of time, and re-adjust it if need be, to allow the sensor to ‘ignore’ material dust that may have collected on the sensor face.

Maintenance

Screen Filter	5-2
Cleaning the Receiver Body.	5-3
Discharge Valve	5-3
Air Valve (Vacuum Sequencing Valve)	5-4
Ratio and Common Material Line Valve	5-4

Screen Filter



CAUTION: When connected to the central vacuum system a receiver has the potential for providing several pinch points when disassembled, including, but not limited to; Air Valve (Vacuum Sequencing Valve), Discharge Valve, Ratio Valve, Common Material Line Valve and Any Vacuum Chamber opening. The Access receiver is part of a central vacuum conveying system. Additional system components (vacuum pump, dust collector, etc.) are covered in separate manuals.

The screen mesh filter that filters material from the conveying air must be cleaned with any material change, but it is advisable to periodically check the screen for material build-up or wear through which could greatly affect performance. Vacuum cleaning or compressed air blow-off are usually all that is required for cleaning. Use safety protection (including safety glasses) to guard against airborne material particles if compressed air cleaning is employed.

The screen also provides the airtight seal between the loader body and the lid that allows the loader to draw material to it, so the perimeter seal of the screen should be closely examined to be sure it is pliable and intact. Examination of the lid clamps is also recommended to insure a proper seal under vacuum.

Receiver Lid Removal:

With the loader lid closed,

- 1 Disconnect compressed air from the Receiver.**
- 2 Disconnect air line of the vacuum sequencing valve cylinder.**
- 3 Loosen the two twist clamps on the perimeter of the lid that lock the lid closed.**
- 4 Keep the lid closed and pull the hinge pin ring from the hinge area of the lid.** The hinge pin connects the receiver lid to the receiver body and provides the pivot point for the hinge action.
- 5 Once released, the lid may then be carefully lifted off of the receiver body.** Use caution as the lid's weight may be deceiving once the lid is released from the hinge.

Reinstalling The Receiver Lid

If the lid was removed from the receiver for service, reinstall it by placing its hinge into the hinge mechanism of the receiver and reinstalling the ringed hinge pin. The lid is likely to require some care in aligning the lid and body hinge components while the hinge pin is installed. Doublecheck that once the pin is installed, the hinge opens and closes easily and that the safety catch operates correctly as the lid is opened.

Cleaning the Receiver body

The receiver body is hinged for easy access to the receiver body. The inside of the receiver body can be wiped clean, vacuumed, or blown with compressed air.

Compressed Air Filter Cleaning

The compressed air connection of the receiver may be connected to a moisture trap to prevent troublesome moisture, contained in the air supply, from entering the receiver. The filter bowl of this moisture trap must be emptied regularly to drain the water from the air system. Inspect the bowl periodically with the compressed air supply turned off, to clean or replace the filter element if needed to remove contaminant accumulation.



CAUTION: Be sure to wear safety glasses to guard against air-borne material particles if compressed air cleaning is employed. Be sure that the compressed air being employed is completely dry and will not add moisture to the filter media. If moisture is added, the collected fines will probably solidify into clumps that will be very difficult to remove. If moisture is accidentally introduced, set the filter aside and allow it to thoroughly air dry before vacuuming at a later time, or replace it with a new filter.

Discharge Valve

The discharge valve should be examined to be sure that its own weight readily closes the valve and that all components are aligned. If any material obstructs the free motion of the discharge valve, clean off the valve thoroughly. If the valve sticks in any position, replace components as required. The discharge valve must make good contact with the sealing ring that surrounds the outlet of the receiver body. If necessary, the seal may be repositioned for better contact by loosening the hose clamp that holds the seal in place.

Air Valve (Vacuum Sequencing Valve)

The plunger on the air cylinder comes in contact with a sealing surface in both the open and the closed position. The seals should be examined to insure that the plunger has an airtight seal in both directions. The seals are sandwiched between the valve housing and the inlet tube on one side, and the cylinder mounting plate on the opposite side, which are held in place by four socket-head capscrews.

Ratio and Common Material Line Valves

The plunger on the air cylinder comes in contact with a sealing surface in the closed position. The seal should be examined for material abrasion or entrapment of material to insure that the plunger has an airtight seal when closed. Clean out any trapped material and replace the seal if required. The seal is sandwiched between the valve housing and the inlet tube, which is held in place by four socket-head capscrews.

Common Line Flapper Valve

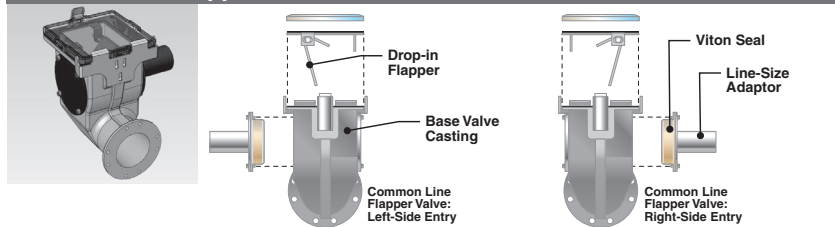

Common Line Pneumatic Valve

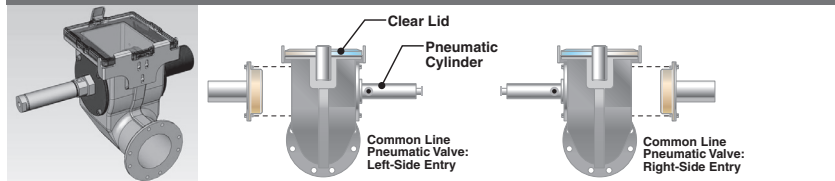

Pneumatic Ratio Valve

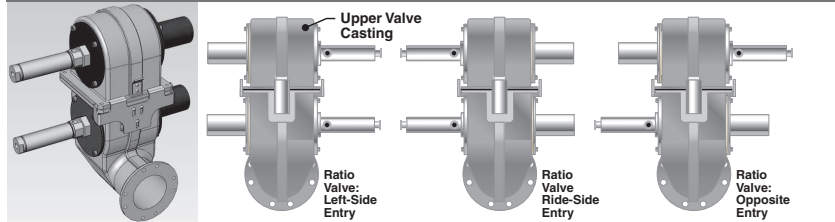

Troubleshooting

Before Beginning.	6-2
Conveying Problems.	6-2

BEFORE BEGINNING

You can avoid most problems by following the recommended installation and maintenance procedures outlined in this User Guide. If you do have a problem, this section will help you determine what caused it and how to fix it.

Before you begin troubleshooting:

Find the wiring diagrams that were shipped with your equipment. These diagrams are the best reference for correcting a problem. The diagrams also will note any custom features, such as special wiring or control options, not covered in this User Guide.

Verify that you have manuals for other equipment in the process line. Solving problems may require troubleshooting malfunctions or incorrect operating procedures on other pieces of equipment.

A FEW WORDS OF CAUTION



WARNING: This machines should be adjusted and serviced only by qualified technical personnel who are familiar with construction and operation of this type of equipment.



WARNING: Voltage hazard.

Troubleshooting the electrical system of this equipment requires use of precision electronic measuring equipment, and may require access to the electrical enclosure while power is on. Exposure to potentially harmful voltage levels may be unavoidable. These troubleshooting procedures should be performed only by qualified electrical technicians who know how to use this precision electronic equipment and who understand the hazards involved.



WARNING: Disconnect power and compressed air before servicing.

Always disconnect and lock out power and compressed air supplies to this equipment before performing maintenance or repair. Failure to do so could result in personal injury caused by the unexpected energization of this equipment.

Conveying Problems



WARNING: Disconnect power and air sources. Always disconnect the pump from the loading control, main power source, compressed air source and before servicing. This prevents the pump from starting during servicing, which could cause personal injury from flying debris or moving parts.

Problem	Possible cause	Solution
Low /no material flow to receiver (Low reading on vacuum pump gauge)	Air leaks in system	<ol style="list-style-type: none">1. Check all vacuum and material lines for wear, holes, couplings and fittings.2. Install and tighten clamps on all flexible hoses.3. Check all system valves for proper operation and seal.
	Feed tube adjustment	Adjust feed tube-add more material as described in <i>Section 4, "Types of Feed Tubes"</i> .
	Out of Material	Restore material supply.
	Feed Tube Adjustment	Adjust Feed Tube-reduce material as described <i>Section 4, "Types of Feed Tubes"</i> , to give a smooth flow and steady vacuum reading on gauge.
	Material Line Blockage	Clear obstruction.

Conveying Problems



WARNING: Disconnect power and air sources. Always disconnect the pump from the loading control, main power source, compressed air source and before servicing. This prevents the pump from starting during servicing, which could cause personal injury from flying debris or moving parts.

Problem	Possible cause	Solution
Low /no material flow to receiver (Low reading on vacuum pump gauge)	Dirty or Plugged filters	<ol style="list-style-type: none">1. Clean receiver screen as described in <i>Section 4, "Screen Filter"</i>.2. Check and clean all systems filters and screens.
	System Valve not opening	Check all Systems Valves (Air valves, Ratio valves, Material Line valves, etc.) for; <ol style="list-style-type: none">1. Control input to solenoid valves.

Additional manuals and prints for your Conair equipment may be ordered through the Customer Service or Parts Department for a nominal fee.

We're Here to Help

Conair has made the largest investment in customer support in the plastics industry. Our service experts are available to help with any problem you might have installing and operating your equipment. Your Conair sales representative also can help analyze the nature of your problem, assuring that it did not result from misapplication or improper use.

How to Contact Customer Service

To contact Customer Service personnel, call:



From outside the United States, call: 814-437-6861

You can commission Conair service personnel to provide on-site service by contacting the Customer Service Department. Standard rates include an on-site hourly rate, with a one-day minimum plus expenses.

Before You Call...

If you do have a problem, please complete the following checklist before calling Conair:

- Make sure you have all model, control type from the serial tag, and parts list numbers for your particular equipment. Service personnel will need this information to assist you.
- Make sure power is supplied to the equipment.
- Make sure that all connectors and wires within and between control systems and related components have been installed correctly.
- Check the troubleshooting guide of this manual for a solution.
- Thoroughly examine the instruction manual(s) for associated equipment, especially controls. Each manual may have its own troubleshooting guide to help you.
- Check that the equipment has been operated as described in this manual.
- Check accompanying schematic drawings for information on special considerations.

Equipment Guarantee

Conair guarantees the machinery and equipment on this order, for a period as defined in the quotation from date of shipment, against defects in material and workmanship under the normal use and service for which it was recommended (except for parts that are typically replaced after normal usage, such as filters, liner plates, etc.). Conair's guarantee is limited to replacing, at our option, the part or parts determined by us to be defective after examination. The customer assumes the cost of transportation of the part or parts to and from the factory.

Performance Warranty

Conair warrants that this equipment will perform at or above the ratings stated in specific quotations covering the equipment or as detailed in engineering specifications, provided the equipment is applied, installed, operated and maintained in the recommended manner as outlined in our quotation or specifications.

Should performance not meet warranted levels, Conair at its discretion will exercise one of the following options:

- Inspect the equipment and perform alterations or adjustments to satisfy performance claims. (Charges for such inspections and corrections will be waived unless failure to meet warranty is due to misapplication, improper installation, poor maintenance practices or improper operation.)
- Replace the original equipment with other Conair equipment that will meet original performance claims at no extra cost to the customer.
- Refund the invoiced cost to the customer. Credit is subject to prior notice by the customer at which time a Return Goods Authorization Number (RGA) will be issued by Conair's Service Department. Returned equipment must be well crated and in proper operating condition, including all parts. Returns must be prepaid.

Purchaser must notify Conair in writing of any claim and provide a customer receipt and other evidence that a claim is being made.

Warranty Limitations

Except for the Equipment Guarantee and Performance Warranty stated above, Conair disclaims all other warranties with respect to the equipment, express or implied, arising by operation of law, course of dealing, usage of trade or otherwise, including but not limited to the implied warranties of merchantability and fitness for a particular purpose.

Remote Demand Sensor Kit with Demand Selector Switch

written instructions on reverse side

Vacuum Receiver Terminal Block

Conair Cable Colors	Control Cable Instructions	15 Earth/Ground	15 Earth/Ground	15 Earth/Ground
green	15 Earth/Ground	13 Power	1 Load	1 Load
red	13 Power	13 Power	2 Ratio	1 Load
black	1 Load	1 Load	3 Discharge	
brown	2 Ratio	2 Ratio	5 BlowBack	
red/yflw	3 Discharge	3 Discharge	4 Purge	
blue	5 BlowBack	5 BlowBack	6 Alarm	
red/grn	4 Purge	4 Purge	7 Fill Sensor	
violet	6 Alarm	6 Alarm	9 Demand	
red/blk	7 Fill Sensor	7 Fill Sensor	10 Sensor Comm	
yellow	9 Demand	9 Demand	11 Sensor Power	
pink	10 Sensor Comm	10 Sensor Comm	14 Neutral	
orange	11 Sensor Power	11 Sensor Power	14 Neutral	
white	14 Neutral	14 Neutral	14 Neutral	
	Cable Pin Numbers			

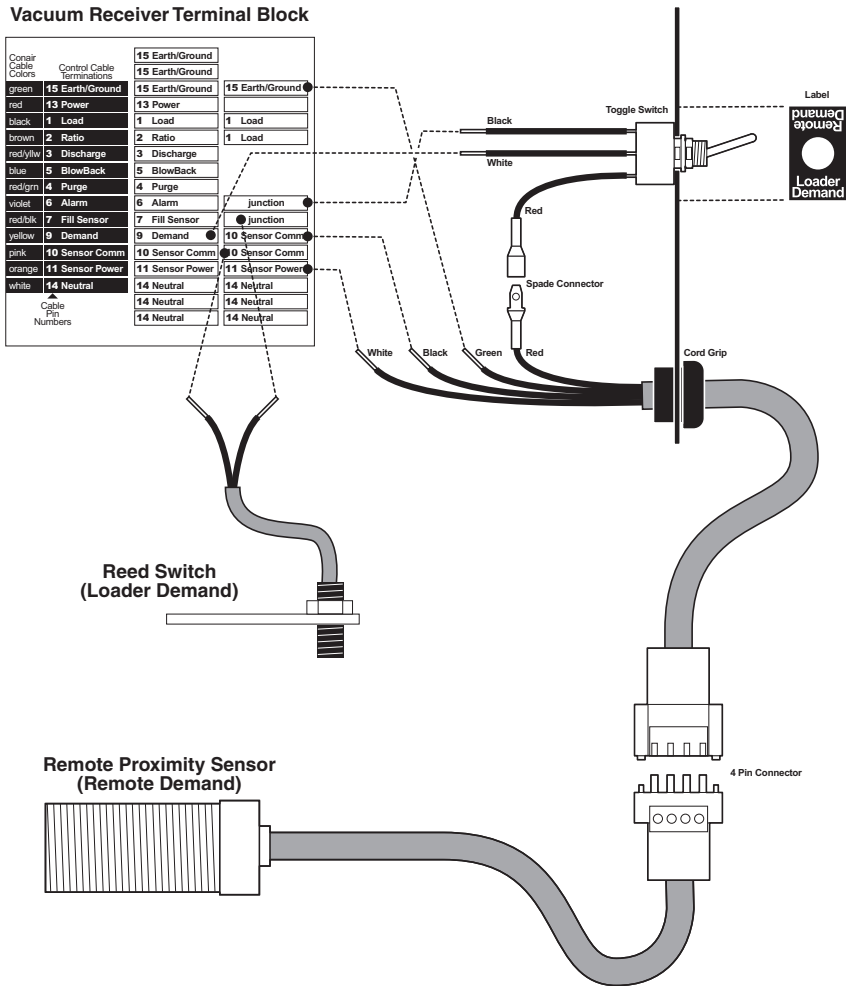

Remote Demand Sensor Kit with Demand Selector Switch

diagram on reverse side

Wiring Instructions

Note: All wiring must be performed by a qualified electrician with strict adherence to local electrical codes:

Prepare terminal box for installation of switch label, switch, and 4 pin receptacle pigtail cable. The switch will be installed in the small hole of the terminal box's top surface. The 4 conductor cable can be located in any of the remaining holes. Remove appropriate hole plugs and clean surface.

1. Peel backing from label and install label over small switch hole. Align long edge of label with adjacent edge of terminal box enclosure.
2. Install switch in the hole so that the terminal with the spade connector is located on the "Loader Demand" side of the label. Use accompanying hardware to firmly secure switch to the terminal box.
3. Install pigtail of 4 pin receptacle cable through the selected hole in the terminal box using the accompanying cord grip. Make sure that there is enough wire length inside the box to connect to the terminal block and switch.
4. Connect the spade terminal from the toggle switch to the spade terminal of the 4 pin receptacle cable.
5. Locate the loader/receiver's reed switch connections on the terminal block. It should be connected to #9 (Demand) and #10 (Sensor Comm). Press the adjacent terminal block lever and remove the reed switch wire from the #9 terminal. Relocate this reed switch wire to either of the "junction" terminals by pressing the adjacent lever of this terminal and inserting the wire. Check to see that it is firmly installed by tugging on it lightly.
6. Insert the wire from the center terminal of the toggle switch into the now vacant #9 (Demand) terminal.
7. Install the remaining wire of the switch into the open "junction" terminal on the terminal block.
8. Connect the 3 remaining wires from the 4 pin receptacle cable as follows:
Connect the Green wire to a #15 (Earth/Ground) terminal.
Connect the Black wire to a #10 (Sensor Comm) terminal.
Connect the White wire to an #11 (Sensor Power) terminal.

Wiring is now complete and providing all wires are firmly connected, the terminal box may now be closed.

Connect the remote demand sensor's plug to the receptacle and route the wire away from hot surfaces and moving parts to the desired sensor location. If the cable will not reach, an extension cable may be ordered from Conair parts or service. Once the sensor is installed and in operation with material, it will need to be adjusted for sensitivity according to instructions included with your loader/receiver.

Using the Remote Demand Sensor

Place the toggle switch in the "Loader Demand" position. Energize the loader/receiver and observe operation. The loader, providing there is no material or other obstruction holding the discharge flapper open, should load repeatedly as expected.

Place the toggle in the "Remote Demand" position. The loader/receiver will now respond to the need for material as determined by the remote demand sensor. In order to work reliably and indicate the presence or absence of material, the sensor is likely to need calibration. Follow the procedure outlined in your Access Loader or Access Receiver instruction manual for sensor calibration.



Remote On/Off Switch Module

written instructions on reverse side

Loader/Receiver Terminal Block

Conair Cable Colors	Control Cable Terminations		
green	15 Earth/Ground	15 Earth/Ground	
red	13 Power	13 Power	
black	1 Load	1 Load	
brown	2 Ratio	2 Ratio	
red/ylw	3 Discharge	3 Discharge	
blue	5 BlowBack	5 BlowBack	
red/grn	4 Purge	4 Purge	
violet	6 Alarm	6 Alarm	
red/blk	7 Fill Sensor	7 Fill Sensor	
yellow	9 Demand	9 Demand	
pink	10 Sensor Comm	10 Sensor Comm	
orange	11 Sensor Power	11 Sensor Power	
white	14 Neutral	14 Neutral	
		14 Neutral	
		14 Neutral	
		14 Neutral	

* Depends on control type

Reed Switch
(Loader Demand)

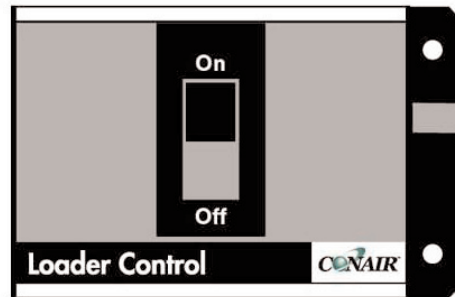

Remote On/Off Switch Module

diagram on reverse side

Wiring Instructions

Note: All wiring must be performed by a qualified electrician with strict adherence to local electrical codes:

1. Remove a hole plug from the top of the terminal box for the on/off switch cable. Install cable through the selected hole in the terminal box using the accompanying cord grip. Make sure that there is enough wire length inside the box to connect to the terminal block and switch.
2. Locate the loader/receiver's reed switch connections on the terminal block. One wire should be connected to #9 (Demand) and the other to either #10 (Sensor Comm) or #11 (Sensor Comm), depending on the control type. Press the adjacent terminal block lever and remove the reed switch wire from the #9 terminal. Relocate this reed switch wire to either of the "junction" terminals by pressing the adjacent lever of this terminal and inserting the wire. Check to see that it is firmly installed by tugging on it lightly.
3. Connect the green wire from the on/off switch to any one of the #15 (Earth Ground) terminals.
4. Insert the black wire from the switch into the #9 (Demand) terminal.
5. Install the white wire of the switch into the open "junction" terminal on the terminal block.

Wiring is now complete and providing all wires are firmly connected, the terminal box may now be closed.

Route the on/off switch wire neatly to the desired location, avoiding hot surfaces or moving parts. It may be mounted to any firm surface using the two holes located on its mounting tab.

Using the Remote On/Off Switch

The on/off switch interrupts the loader or receiver's demand input, to prevent further loading. If the switch is moved to the off position during loading, the loading cycle will finish, but prevent another cycle from starting.

To test the switch:

1. Make sure that no material or any other blockage is keeping the loader/receiver's discharge flapper from closing and energize the loader/receiver.
2. With the switch in the "ON" position, the loader/receiver should operate normally.
3. Switch to the "OFF" position. The loader/receiver should complete the current loading cycle and then halt all further loading.