

User Guide

Gravimetric Blenders

**GB and WSB models
with 4-component control**

Installation

Maintenance

Operation

Troubleshooting



WARNING - Reliance on this Manual Could Result in Severe Bodily Injury or Death!

This manual is out-of-date and is provided only for its technical information, data and capacities. Portions of this manual detailing procedures or precautions in the operation, inspection, maintenance and repair of the product forming the subject matter of this manual may be inadequate, inaccurate, and/or incomplete and cannot be used, followed, or relied upon. Contact Conair at info@conairgroup.com or 1-800-654-6661 for more current information, warnings, and materials about more recent product manuals containing warnings, information, precautions, and procedures that may be more adequate than those contained in this out-of-date manual.

***Instant Access
Parts and Service
(800) 458-1960
(814) 437-6861***

www.conairnet.com

CONAIR™

The Conair Group, Inc.
One Conair Drive
Pittsburgh, PA 15202
Phone: (412) 312-6000
Fax: (412)-312-6320

UGB006/1103

Please record your equipment's model and serial number(s) and the date you received it in the spaces provided.

It's a good idea to record the model and serial number(s) of your equipment and the date you received it in the User Guide. Our service department uses this information, along with the manual number, to provide help for the specific equipment you installed.

Please keep this User Guide and all manuals, engineering prints and parts lists together for documentation of your equipment.

| |
|--|
| Date: |
| Manual Number: UGB006/1103 |
| Serial number(s): |
| Model number(s): |

Mrev:1/17/2003

DISCLAIMER: The Conair Group, Inc., shall not be liable for errors contained in this User Guide or for incidental, consequential damages in connection with the furnishing, performance or use of this information. Conair makes no warranty of any kind with regard to this information, including, but not limited to the implied warranties of merchantability and fitness for a particular purpose.

The Conair Group Inc.
FOUR COMPONENT SOFTWARE
GB and WSB Model Blenders

TABLE of CONTENTS

| | | |
|--|------|----|
| GETTING STARTED, READ THIS PAGE | Page | 3 |
| SAFETY HAZARDS | Page | 4 |
| DISCLAIMERS | Page | 5 |
| PART I - ASSEMBLY | | |
| Assembly and Installation Instructions | Page | 6 |
| Wiring Considerations | Page | 10 |
| Check Out Procedure & Diagnostics | Page | 11 |
| Selecting Correct Model | Page | 14 |
| PART II - OPERATION | | |
| Load Cell Calibration | Page | 15 |
| Rate Calibration | Page | 16 |
| Selected Models - Special Instructions | Page | 17 |
| Instructions for Normal Operation | Page | 18 |
| Special Features | Page | 19 |
| Controls and Outputs | Page | 21 |
| Keypad - Summary description | Page | 26 |
| Automatic mode | Page | 27 |
| Manual Mode | Page | 31 |
| Program Mode | Page | 34 |
| Parameters - Short & Long Explanations | Page | 44 |
| Default Settings | Page | 68 |
| Changing / Saving Parameters | Page | 70 |
| PART III - PRINTER OUTPUTS | | |
| Monitoring System Accuracy | Page | 71 |
| Special Tests | Page | 77 |
| Material Usage Information | Page | 78 |
| PART IV - TROUBLESHOOTING / SOFTWARE | | |
| What To Do | Page | 79 |
| Increasing Throughput | Page | 80 |
| Typical Problems | Page | 81 |
| Normal Operating Sequence | Page | 83 |
| Verifying Load Cell Function | Page | 85 |
| Clear RAM, Clear ALL, Full Software Restart | Page | 88 |
| PART V - HARDWARE MAINTENANCE | | |
| Hardware Adjustments | Page | 89 |
| Mix Problems | Page | 91 |
| Recalibration of Load Cells | Page | 93 |
| Preventive Maintenance | Page | 94 |
| Model GT - TOTALIZER Instructions | Page | 95 |
| Wiring diagram & Supplements | Page | 97 |
| Exploded Views and Parts List | Page | 98 |
| Warranty | Page | 99 |

The Conair Group Inc.
One Conair Drive
Pittsburgh, PA 15202
412-312-6000
FAX # 412-312-6227

GETTING STARTED, READ THIS PAGE.

THE NEXT 9 PAGES OF THIS MANUAL WILL GUIDE YOU, STEP BY STEP, TO A SUCCESSFUL STARTUP.

IT WON'T TAKE LONG; SO.... PLEASE, DON'T SKIP AHEAD.

HERE ARE THE STEPS YOU WILL FOLLOW.

SAFETY HAZARDS: Two hazards exist on this unit: mix blades and
Page 4 slide valves. Read this short sensible page
so no one gets hurt.

ASSEMBLY INSTRUCTIONS: Very little assembly is required. But you
Page 6 might as well get it right the first time.
ALSO: pay attention to the section on wiring.

CHECK OUT PROCEDURE: This is to see if you did it right. It also
Page 11 will tell if anything was damaged in shipping.

LOAD CELL CALIBRATION: We already did this. But shipping or rough
Page 15 handling during assembly sometimes creates load
cell problems. If weight readings are not
correct, you MUST recalibrate the load cells.

RATE CALIBRATION: This is NOT really necessary. But if your
Page 16 system uses non-standard equipment then you
MAY want to do this.

SPECIAL INSTRUCTIONS: A few selected models require special
Page 17 instruction. If your model is listed on this
page, read these instructions.

NORMAL OPERATION: From this point forward, operating your system
Page 18 is a snap. This section tells you just how
simple it is and exactly what to expect under
normal operating conditions.

SPECIAL FEATURES: Your system can do much more than you may
Page 19 know. This page reviews briefly some of the
added features that are available to you and
where in this manual you can find them.

+-----+
|
| PROCEED TO: SAFETY HAZARDS NEXT PAGE |
|
+-----+

MIX BLADES

Mix blades are driven with substantial torque.

NEVER place your hand in the mix chamber
unless power is completely disconnected.

SERIOUS INJURY may result.

ADDITIONAL MIX BLADE HAZARD

Over time, mix blades may become RAZOR SHARP.

Always be careful when TOUCHING or CLEANING these blades.
Check for sharp edges frequently.
Replace blade if a hazard exists.

SLIDE VALVES

Slide valves in hoppers SLAM CLOSED without warning.
They WILL injure your fingers.

ALWAYS keep fingers clear of slide gate openings.
NEVER use your fingers to clear an obstruction.
NEVER use your fingers to move a sticking slide gate.

SAFETY FEATURES

SAFETY INTERLOCK SWITCH

The ACCESS DOOR is equipped with a safety interlock
switch that prevents the mix motor from running and
the slide valves from operating.

DO NOT defeat this safety switch.

HOPPER FINGER GUARDS

Finger guards are fitted into each hopper compartment.
DO NOT reach through these guards.
DO NOT use your fingers to clear an
obstruction below these guards.

DO NOT remove these guards.

PROCEED TO: ASSEMBLY NEXT PAGE

PRODUCTION of FAULTY PRODUCT

Processing conditions and materials vary widely from customer to customer and from product to product. It is IMPOSSIBLE for us to anticipate ALL processing conditions and requirements, or to be certain that our equipment will perform properly in all instances. You, the customer, must observe and verify the performance level of our equipment in your plant as part of your overall manufacturing process. You must verify to your own satisfaction that this level of performance meets your requirements. We CAN NOT be responsible for losses due to product that is blended incorrectly, even when due to equipment malfunction or design incorrect for your requirements; and/or for any consequential losses due to our equipment not blending to your requirements.

We will only be responsible to correct, repair, replace, or accept return for full refund if our equipment fails to perform as designed, or we have inadvertently misrepresented our equipment for your application.

ACCURACY of THIS MANUAL

We make every effort to keep this manual as correct and current as possible. However, technology and product changes occur more rapidly than the reprinting of this manual. Generally, modifications made to the design of the blender or to the operation of the software are not reflected in the manual for 3 to 6 months. We always reserve the right to make these changes without notice, and we do not guarantee the manual to be entirely accurate. If you question any information in this manual, or find errors, please let us know so that we may make the required corrections. We will gladly provide you with updated manuals.

-----+
| PART I - ASSEMBLY |
+-----+

ASSEMBLY and INSTALLATION INSTRUCTIONS

CAUTION: LOAD CELLS ARE EASILY DAMAGED.

If the FRAME is dropped from TWO FEET, the load cells WILL be DAMAGED.
PLEASE, BE CAREFUL.

The following items have been shipped to you:

1. FRAME, fully assembled: (bolted to pallet)
2. CONTROLLER: the controller and the instruction manual.
3. FEEDERS: optional COLOR or ADDITIVE feeders as ordered.
4. FLOW CONTROL ASSEMBLY: optional
5. FLOOR STAND or VACUUM TAKEOFF ASSEMBLY: optional

RED INSTRUCTION STICKERS will assist you during assembly.

LIFT HANGERS are available to allow lifting of the blender with a strap or chain. Call us if you require them.

1A. If your unit is to be MACHINE mounted:

For GB/WSB 100, 200, and 400 series models:

Two ways to do this are suggested ON THE NEXT PAGE.

The LEFT diagram shows the FRAME and SLIDE GATE both drilled with the proper bolt pattern for your machine and THROUGH-BOLTED to your press.

The RIGHT diagram shows only the 10 x 10 steel slide-gate plate drilled for your bolt pattern and bolted to your press. The FRAME is then bolted to it using the 8 x 8 inch bolt pattern holes and bolts provided. With this method, bolt head clearance holes are required in the poly-pro slide gate plate. This mounting works well on smaller machines.

For GB/WSB 900 and 1800 series models:

An additional machine mount adaptor plate may be required. If you have ANY DOUBT about the STABILITY of the unit when bolted directly to your machine throat, please call us for advice.

NOTE: When choosing proper orientation, be sure you have access to the controller and weigh chamber, clearance for hinged doors, and access to removable feeder hoppers.

1B. If your unit is STAND mounted:

A stand is provided and your unit will bolt directly to it.

An assembly DIAGRAM is provided if stand assembly is required.

An air operated FLOW CONTROL ASSEMBLY is provided for dispensing into a container. The purpose of this unit is to allow time for mixing to occur after each dispense. This flow valve keeps the mix chamber full to just below the sensor. This assembly bolts directly to the bottom of the Blender frame.

2. Slide the WEIGH BIN into position. It rests high in the frame and is inserted from the side that has the hinged access window. Install with the air cylinder toward you. If bin is already in place, remove any shipping materials, tape or string.
3. Hang the Color and Additive Feeders:
 - a. Lift side latches and fully extend slide assembly. Remove the hopper. Leave slide extended.
 - b. Raising the rear of the slide assembly, insert one corner of hanger cross bar behind frame corner post.
 - c. Rotate assembly into place so both ends of cross bar are behind corner posts.
 - d. Lower into place, bottom edge resting on frame and cross bar properly positioned behind corner posts.
 - e. Re-install hopper. Slide motor forward until latches engage.
4. Place the controller on the support tray and plug in all cords:
 - a. Air solenoids into the multi-pin plug.
 - b. Additive and color feeders into panel front receptacles.
 - c. Mixer motor into right side of controller.
 - d. Sensor cord plug into right side of controller.
 - e. Load Cell plug into port on left side of controller.
5. Plug the CONTROLLER into the receptacle box located under the controller tray on GBM, 100, 200, and 400 series models; and in the mix motor relay box on 900 and 1800 series models.

IMPORTANT: Do NOT plug the controller into a separate power source. The controller ground path MUST be the same as the blender frame ground path. If your system has the controller located in a remote location, MAKE CERTAIN that the power to the controller comes from the receptacle mounted on the Blender frame.

6. Plug the power cord coming from this box into a 110 volt power source (230 volt outside U.S.). This cord MUST provide the ONLY power source for the entire system, including the controller. See WIRING CONSIDERATIONS, next page. 1800 series blenders require a separate power source for the mix motor.
7. Connect air pressure to the unit. About 80 psi (5.5 bar) is recommended. Lubricated air is NOT recommended.

NOTE: Micro Blenders should be set to 40 psi (2.7 bar). The Vertical Valves used in removable hoppers on Micro Blenders, and 100 and 200 series blenders, are more accurate at the lower 40 psi pressure setting.

8. Remove all protective paper from the plastic windows.

WIRING CONSIDERATIONS

The wiring of your blender is very important to its proper operation. Electronics are very susceptible to voltage spikes and static charges, both of which are very common in plastics factories.

To MINIMIZE these things, consider the following.

1. The power supply should be solid; a strong supply, not limited by a "just adequate" control transformer. A source of voltage that comes from a large transformer that supplies a large portion of the plant is better than a small power supply transformer that is intended to supply only this device. Power supplies, even though they may be "isolation" transformers, will still pass all voltage spikes right through. Their small size limits their ability to dampen RF (Radio Frequency) noise that is often induced into the system from outside sources. This proves worse than connection to larger central transformers.
2. Avoid running the power supply line along side any heavy power lines. An unshielded power supply in a raceway along side other heavy power lines will pick up induced RF noise and transfer it into the GB/WSB steel enclosure causing computer trouble.
3. Long extension cords should be avoided. They also reduce the ability to provide a dampening effect on spikes and static. The further the equipment is from a substantial power source, the more susceptible it is to spikes.
4. The CONTROLLER and the GB/WSB frame MUST share the same GROUND PATH. This is why you MUST plug the controller into the OUTLET that is provided ON THE FRAME of the blender.
5. REMOTE SYSTEMS. If you have your controller mounted in a remote location, you will have a number of power and signal cords running between the frame and the controller. BE SURE that the LOW VOLTAGE lines are NOT BUNDLED to the HIGH VOLTAGE lines and keep them away from other nearby electrical lines.

LOW VOLTAGE lines are: Load Cell cable, Level Sensor cord, Air Solenoid cable, and Printer and Computer cables.

HIGH VOLTAGE lines are: Mixer motor cable, feeder motors, and MAIN POWER line.

Keep these sets of cables SEPARATED.

6. VACUUM LOADER CONVEYING LINES. Keep them away from all electrical lines, particularly the Load Cell lines. Conveying plastic produces extreme static sources. A power supply line, even in conduit, that runs next to a vacuum line, can introduce extreme static pulses into the processor. Keep conveying lines SEPARATED from electrical supply lines.
7. We use many internal tooth "STAR" washers in assembly to ensure a good ground path between painted parts. Do not remove them.

```
+-----+
|  PROCEED TO:    CHECK OUT PROCEDURE    NEXT PAGE  |
+-----+
```

CHECK OUT PROCEDURE

As you go through this procedure, if WHAT SHOULD HAPPEN, doesn't happen, see the next section, DIAGNOSTICS, for what to check.

NOTE: 100 and 200 series models (3K load cells), display all weight readings in 1/10 grams (x.x). 400, 900, and 1800 series models (10K load cells) display in FULL grams, no decimal.

On this page we show all weight readings WITH a decimal point.

Start with NO MATERIAL in any hoppers.

Be sure an AIR SUPPLY is connected.

Place ALL switches DOWN; POWER (on front); STOP and PAUSE (on left).

| PROCEDURE: | WHAT SHOULD HAPPEN: |
|-------------------------------|---|
| PLUG IN CONTROLLER. | Nothing should happen. Air pressure should be holding ALL valves CLOSED. This means all air cylinders are extended. If any slide gate or flap is open, air lines are reversed. |
| TURN POWER ON. | Display should show (FOUR), software type, followed by version date (V=50920A), followed by the check sum number (CKS xxxx), followed by (ROM OK), followed by (RAM = 8K), followed by (MODEL220) or MB, 140, 131, 122, 240, 420, 440, 940, 1840. (NOTE: The MODEL number must match your unit, except for the zero. If not see below.) followed by (0.0), followed by the actual weight of material in the bin. This number should be close to 0, plus or minus several grams (20.0) to (- 20.0). |
| AT THIS POINT: | Be sure the display is in tenths of grams, or full grams depending on your model. If the weight display is NOT correct, or the MODEL number is not correct; see SELECTING CORRECT MODEL, next section. |
| TOUCH WEIGH BIN VERY LIGHTLY. | Display should update the weight every second reflecting the light pressure that you are exerting on the bin. |
| PRESS "*" KEY | Display will say (PASSWORD) |
| PRESS "22222" | (2 key five times) (entering the Program mode) 2's will be displayed as you enter them. Display will show (P x.x) when done. |
| PRESS "OPER" KEY | Display will say (OPERATE) |

PRESS "REG" KEY Regrind air solenoid will operate.
 LED # 1 will light.
 The Regrind dump valve will open.
 Press "REG" repeatedly to observe operation.

PRESS "NAT" KEY Natural air solenoid will operate.
 LED # 2 will light.
 The Natural dump valve will open.
 Press "NAT" repeatedly to observe operation.

PRESS "COL" KEY Internal relay will close powering Color outlet.
 Color feeder will run.
 LED # 3 will light.
 Press "COL" repeatedly to observe operation.

PRESS "ADD" KEY Relay will close powering Additive outlet.
 Additive feeder will run.
 LED # 4 will light.
 Press "ADD" repeatedly to observe operation.

PRESS "DUMP" KEY The dump air solenoid will operate.
 LED # 5 will light.
 The weigh bin dump valve will open.
 Press "DUMP" repeatedly to observe operation.

PRESS "ALARM" KEY The Strobe Light and Beeper will operate.
 LED # 6 will light.

PRESS "MIX" KEY The Mixer Motor will run.
 LED # 7 will light.
 (Mix blade turns counter clockwise when observed
 through window.)
 (Mixer switch must be down; timed position.)

PRESS "HOLD" KEY The Flow Control Valve will operate.
 (This is an optional device).
 LED # 8 will light.

PRESS "EXIT" KEY Press two times to return to normal mode.
 Verify normal mode by observing that there is NO
 letter P in the display (x.x).

```

+-----+
|           If you have made it this far, congratulations.           |
|                   You have done well.                             |
|   The load cells and controller are functioning properly.         |
+-----+

```

```

+-----+
|   PROCEED TO:   LOAD CELL CALIBRATION   Skip 2 Pages             |
+-----+

```

DIAGNOSTICS - for the CHECK OUT PROCEDURE

- If display fails to come on at all:
check for power at outlet.
Check the 1/2 amp fuse on panel front.
- If first display says (TWELVE), this is NOT the correct manual for this software. Obtain a TWELVE software manual.
- Possible model numbers are: 140, 220, 240, 420, 440, 940, 1840.
If model number is not correct for you unit:
see the next page, SELECTING CORRECT MODEL.
- If display stays at (0.0):
check for damage to load cells or load cell wires.
Load cell distorted upward may produce a display of (0.0).
- If unit displays randomly drifting numbers:
check to see load cells are plugged in.
- If display shows about (- 1250.0) or (-4500) for 900 series:
check that the weigh bin is in place resting on the load cells. This number is about the weight of the weigh bin.
- If display is steady but not near zero:
Recalibration of load cells will most likely fix this. This is covered in next section.
- If there is no response from the display when the bin is touched:
check that load cell plug screws are secure.
- If response is not sensitive or does not return to its start point:
check for interference around weigh bin.
- If pressing * does not display (PASSWORD):
you are not in the normal power-up mode or the keypad doesn't work. Normal mode is indicated by the ABSENCE of the letter M or P at the left of the display.
- If display says INVALID after entering the password number:
you pressed the wrong keys or the password number has been changed and it is no longer 22222. Call us for help.
- If an air solenoid does not operate:
check the 1/2 amp fuse.
check solenoid cable connected properly and fully seated.
check mix chamber door closed, safety interlock engaged.
- If a slide or dump valve does not open:
check that the air supply is connected.
check for proper air line connections to cylinder.
- If color or additive auger motor does not run:
check the 3 amp fuse.
check that the motor is plugged into proper outlet.
check for faulty motor by plugging it into a known source of 110 volt A.C. power.

We program every controller to match the model it is shipped with. If your controller DOES NOT display the correct model (first two digits only) on power up, follow these instructions.

There are SEVEN basic models of Weigh Scale Blenders. The MODEL number your unit is set for (first two digits only) is displayed during the start up sequence every time power is turned on. Disregard the last digit of your model number when selecting from this list.

The possible models are:

| MODEL | BATCH WEIGHT (GRAMS) | WEIGH BIN DIMENSIONS | # DISPENSE VALVES | LOAD CELL RATING |
|------------------|-------------------------|-------------------------|----------------------|---------------------|
| GBM Microblender | 400 | 5 x 5 x 5 high | 4 | 1 @ 3 K |
| 140,131,122,14R | 1000 | 10 x 6 x 6 high | 4 | 1 @ 3 K |
| 220 | 2000 | 10 x 10 x 7 high | 2 | 2 @ 3 K |
| 240,24R | 2000 | 10 x 10 x 7 high | 4 | 2 @ 3 K |
| 420,44R | 4000 | 10 x 10 x 10 high | 2 | 2 @ 10 K |
| 440 | 4000 | 10 x 10 x 10 high | 4 | 2 @ 10 K |
| 940 | 9000 | 16 x 16 x 12 high | 4 | 2 @ 10 K |
| 1840 | 18000 | 16 x 16 x 17 high | 4 | 2 @ 20 K |

400, 1000 and 2000 gram systems with 3 kg. load cells; weights are displayed in tenths of grams (xxxx.x).

4000, 9000, and 18000 gram systems with 10 or 20 kg. load cells; weights are displayed in full grams (xxxxx).

If your unit is NOT set correctly to match the hardware you have, you must change it. To do so:

Turn power on. From the NORMAL mode:

```

+-----+
| Press: *      Display will say: (PASSWORD) |
| Press: 97531  Display will say: (MODEL240) |
|              or whatever model it is set for. |
| Press: *      To walk through all seven models. |
|              When the model you want is displayed, |
|              then: |
| Press: EXIT   Wait a few seconds. |
|              Unit will reset and restart |
|              as the system you have selected. |
+-----+

```

When switching models, all parameter table information is lost and the new "default" information for this model is loaded from ROM.

RATE CALIBRATION

RATE CALIBRATION is probably not necessary. The software initially expects STANDARD hardware. However, if you are using an auger feeder on a model with four dispense valves, or a 1/2 inch auger instead of a 1" auger, the software will take 10 or 20 cycles to adjust to correct operation. This slows down the process for a short time, but does not effect accuracy.

If your hardware is STANDARD, or you prefer letting the system SELF ADJUST, you may:

```

+-----+
|
|  PROCEED TO:      NORMAL OPERATION      NEXT PAGE  |
|
+-----+

```

To perform a RATE CALIBRATION:

Have all HOPPERS LOADED with enough material to run for several cycles without running out.

Have the "OFF AT END OF CYCLE" and "PAUSE" switches DOWN.

Press: * Display will say: (PASSWORD)
Press: 22222 Display will say: (P x)

If your system has auger feeders, operate them briefly to ensure they are fully primed. To do so:

Press: OPER Display will say: (OPERATE)
Press: COL Run until auger is dispensing.
Press: ADD Run until auger is dispensing.
Press: DUMP This will empty the weigh bin.

Now you can CALIBRATE EACH material.
To do so:

Press: CAL Display will say: (CALIBRATE)
Press: REG REGRIND will calibrate itself.

For each material, press CAL followed by the proper component key. Each time a dispense will occur, followed by weighing, followed by a dump to empty the weigh bin.

Press: EXIT when all calibrations are done.

YOU ARE NOW READY FOR ACCURATE PRODUCTION BLENDING.

```

+-----+
|
|  PROCEED TO:      SPECIAL INSTRUCTIONS      NEXT PAGE  |
|
+-----+

```

SELECTED MODELS - SPECIAL INSTRUCTIONS

This section relates SPECIAL information about a few selected models.

MICRO PULSE

Micro Pulse valves are available on models:

GB/WSB MB (MICRO Blender) with optional MICRO PULSE valves.
GB/WSB 122 with optional MICRO PULSE valves.
GB/WSB 131 with optional MICRO PULSE valves.
GB/WSB 140 with optional MICRO PULSE valves.
GB/WSB 240R with optional MICRO PULSE valves.
GB/WSB 440R with optional MICRO PULSE valves.

These models may use our "MICRO PULSE" metering system for Color and Additive components.

PULSED OUTPUT parameters control the on/off timing, or pulsing, of the valves. The controlling parameters are the "_PO" component parameters.

When set to 00000, normal slide gate operation occurs.

When set to a value, such as 00101, power will pulse ON then OFF, at 1/10 second time intervals each way. This ON/OFF cycling will repeat for the entire dispense time.

When using a MICRO PULSE valve, you must set the related _PO parameter to 00101.

If overall blender throughput is too low, you may increase the metering rate of each Micro Pulse device by adjusting the cylinder air flow control valves for higher flow rate. This causes more rapid movement of the cylinder, ejecting more pellets per pulse. The drawback is noisy operation.

We recommend air flow be adjusted for quiet operation, but assuring full valve movement per on/off cycle. We have already done this. No further adjustment should be necessary.

The approximate correct adjustments are:

At nose of cylinder, 1.5 full turns out from full closed.
At rear of cylinder, 2.5 full turns out from full closed.
MICRO BLENDER slant valves, adjust by sound.

On fixed hoppers with horizontal micro pulse valves, CLEAN OUT of the hopper can be accomplished by opening the "clean out" port provided under the valve. Turn to one side to allow material to drain.

MICRO PULSE - ACCURACY

All MICRO PULSE valves are more accurate if the associated PT parameter is set to 00090. Read PT parameter in the PARAMETER section.

```
+-----+
|      |
| PROCEED TO:    NORMAL OPERATION    NEXT PAGE      |
|      |
+-----+
```

INSTRUCTIONS FOR NORMAL OPERATION

OPERATION: ...very simple.

1. Fill HOPPERS: REGRIND, NATURAL, COLOR, ADDITIVE:
in hoppers as labeled.
If auger feeders are used:
COLOR in RIGHT side feeder,
ADDITIVE in LEFT side feeder.
2. Set THUMBWHEEL switches for percentages desired.
REGRIND, enter as a percent of the entire mix. (xx percent)
COLOR, as a percent of the NATURAL. (xx.x percent)
ADDITIVE, as a percent of the NATURAL. (xx.x percent)
3. On Controller, turn POWER ON, set STOP, and PAUSE switches UP.
Switch MIXER motor DOWN to run for a timed period each cycle.

Unit will now operate automatically to maintain a level of material high enough to cover the sensor.

Use the STOP or PAUSE switches to stop the dispensing of material. Turn POWER off only on final shutdown. Battery-backed RAM ensures all information is retained even with power turned off.

The KEYPAD is only for: 1. MANUAL TESTING.
2. ALTERATION of INTERNAL PARAMETERS

AFTER SEVERAL DAYS OF PROPER OPERATION:

Save all parameter information to the EEPROM for future retrieval should software problems develop later.

To SAVE all parameter information to the EEPROM:

```
+-----+
| Press: *           Display will say: (PASSWORD) |
| Press: 22222       Display will say: (P  x.x) |
| Press: *           Display will say: (INSTR --) |
| Press: 23          Display will say: (SAVING  ) |
| Wait:  when done, Display will say: (P  x.x) |
| Press: EXIT        Display will say: (  x.x) |
+-----+
```

IF PROBLEMS DEVELOP:

RETRIEVE this correct copy of the parameters from the EEPROM. This clears corrupted data from RAM and corrects most software problems.

```
+-----+
| Switch:  POWER OFF. |
| Hold:    the "CE" key down. |
| Switch:  POWER ON. |
| Release: the "CE" key. |
|           Display will say ( CLEAR  ) |
|           If you do not see ( CLEAR  ) |
|           on the display, do it again. |
+-----+
```

NORMAL OPERATING SEQUENCE - EACH CYCLE

As the sensor is uncovered, the cycle begins. The target weight of a complete depends on model; 400, 1000, 2000, 4000, 9000, or 18000 grams.

REGRIND, if requested, will dispense first. After the Regrind dispense the space remaining in the weigh bin is calculated.

NATURAL will dispense second. This dispense is calculated to fill the bin leaving just enough space for the Color and Additive dispenses. After the Natural dispense is complete the exact weight of this dispense is calculated and, based on this actual dispense weight, the Color and Additive dispenses are now calculated.

COLOR and ADDITIVE are now dispensed one at a time as requested. These dispenses are a percentage of the Natural component only.

If the Natural, Color, or Additive components fail to reach the requested weight, the process does NOT CONTINUE. The ALARM Strobe light flashes and the system holds until the problem is remedied.

As each component is being dispensed and weighed, the corresponding letter (R, N, C, or A) is displayed. The total updated bin weight is displayed about 3 seconds AFTER each dispense.

Each dispense weight is checked and recorded. Rate recalibration takes place every cycle to ensure continuous process accuracy.

The total batch is dropped into the mixing chamber and blended before entering the throat of the process machine.

SPECIAL FEATURES

To use one of these SPECIAL FEATURES, read about it first, then follow the directions on next page to make the proper changes.

To store RECIPES using the RECIPE storage feature, read:
KEYPAD, RECIPE key, and set 3rd digit in the FLG parameter to 1.

To blend a preset BATCH amount of material and then stop, read:
KEYPAD, BATCH key, and set 5th digit in the FLG parameter to 1.

To increase throughput, using the FAST key, read:
KEYPAD, FAST key, and set 4th digit in the FLG parameter to 1.

To TAG all material usage data with Work Order or Employee numbers for better tracking of material used, read:
KEYPAD, TAG key, and set 2nd digit in the FLG parameter to 1.

BATCH, RECIPE, FAST, and TAG keys REQUIRE that you read:
PARAMETERS, FLG parameter.

To change the MIXER RUN TIME, read:
PARAMETERS, MIX Parameter.

To run a LOWER PERCENTAGE then 00.1 percent, read:
PARAMETERS, _XT parameter.

To place UPPER LIMITS on the thumbwheel settings, read:
PARAMETERS, _SE Parameter.

To LOCK OUT others from changing settings, read:
KEYPAD, STAR FUNCTIONS, (*78) - Changing the Password.

To blend TWO NATURAL materials instead of Natural and Regrind, read:
KEYPAD, STAR FUNCTIONS, (*69) - the TWO NATURALS flag.

To TRACK MATERIAL usage, read:
KEYPAD, VIEW DATA, and PARAMETERS, PRT Parameter.

To VERIFY ACCURACY of the entire system, read:
PRINTER OUTPUT and TROUBLESHOOTING sections.

READ the rest of the manual at your leisure to learn more about how
your WEIGH SCALE BLENDER works and what else it can do.

KEYSTROKE SEQUENCE for these or other SPECIAL FEATURES

With STOP END OF CYCLE switch DOWN,
Turn POWER ON. Wait 5 seconds, until display says (x.x)
Press: * Display will say (PASSWORD)
Press: 22222 Display will say (P x.x)
This is the PROGRAM MODE

To alter a PARAMETER; press: PARA key
Press repeatedly until the parameter you want is displayed.
If you pass it, use the * key to back up.
With the proper one displayed, enter the NEW parameter number.
Enter 5 digits; use leading zeros if necessary.
For correct entries, follow specific directions given in the
PARAMETER section.

Press: EXIT when correct parameter has been entered.

To make a (*XX) entry:
Be in the PROGRAM mode, same as above.
Display will say (P x.x)
Press: * Display will say (INSTR --)
Enter the 2 digit code.
For correct entries, follow specific directions given in the
KEYPAD section, STAR FUNCTIONS.

Press: EXIT when correct information has been entered.

When finished, press EXIT again to exit the PROGRAM MODE.

CONTROLS and OUTPUTS

1. POWER ON switch.

Controls all power to the controller and all outputs. When power is switched off, battery backed-up RAM preserves all internal totals and parameters. All other functions are reset for normal start-up when power is restored.

2. STOP END OF CYCLE / CONTINUE switch

This is the PREFERRED STOP switch. This switch is wired in series with the level sensor. Turning it off breaks the signal to the computer the same as covering the level sensor with material. This stops the process at the end of a full cycle.

3. IMMEDIATE PAUSE / CONTINUE switch

Causes a computer-controlled immediate pause in the cycle. Dispenses will stop in mid dispense if necessary. When switched back to CONTINUE, the process continues without any error in amounts dispensed.

4. REGRIND thumbwheel switch (00 to 99)

This setting represents the PERCENT of the ENTIRE MIX that is to be REGRIND.

A lower limit of 5% (05) has been entered into the software. This limit may be altered using the keypad (see parameters, RLO).

A setting of "99" causes the system to run 100 percent regrind. With this setting, no attempt is made to meter natural, color, or additive unless the regrind dispense fills less than 1/2 of the weigh bin.

5. COLOR thumbwheel switch (00.0 to 99.9)

This setting represents the PERCENT of the NATURAL PORTION that is to be COLOR. For example, if your COLOR to NATURAL mix ratio is 1:25 then "04.0" is the proper setting. (1 pound of color to 25 pounds of natural is $1/25 = 4\%$)

6. ADDITIVE thumbwheel switch (00.0 to 99.9)

This setting represents the PERCENT of the NATURAL PORTION that is to be ADDITIVE. For example, if your ADDITIVE to NATURAL mix ratio is 1:100 then "01.0" is the proper setting ($1/100 = 1\%$).

7. ALL AIR SOLENOID outputs

This is a single 17 pin Amphanol plug located on the front of the control panel. This provides 24 volt power for the NATURAL, REGRIND, WEIGH BIN DUMP, and FLOW CONTROL (optional) air solenoids. On Models 140, 240, 440, 940, and 1840 (FOUR valve units), COLOR and ADDITIVE dispense valve solenoids are also powered. These power sources are transistor driven and are protected by the 1/2 amp panel fuse. See the wiring diagram section for the correct wiring to each pin.

8. COLOR and ADDITIVE power outlets (certain models only)

Each outlet puts out 120 volts (220 volts outside U.S.A.) through internal plug-in solid state relays rated at 5 amps and fused at 3 amps. These relay outputs are designed to drive motors or other devices requiring power up to 3 amps each.

The COLOR outlet is driven based on the COLOR setting. The ADDITIVE outlet follows the ADDITIVE setting. COLOR dispense occurs first but has no effect on the ADDITIVE dispense. The amount of each dispense is calculated based on the NATURAL dispense that precedes them.

9. EIGHT CHARACTER DISPLAY

Displays the accumulated total bin weight, in grams, 2 seconds after each dispense. The display flashes when an inadequate dispense has occurred and the dispense is going to be retried. Other information displayed here includes material usage totals, internal parameters, current thumbwheel settings or keypad entered settings, and various information prompts to assist the operator.

####.# Numbers displayed are the total weight of material, in grams, in the bin at any time. The weight in the bin is updated 2 seconds after an each dispense is completed. During the dispense the displayed weight does not change.

P in the left most position indicates unit is in PROGRAM mode.

M indicates unit is in MANUAL mode.

R, N, C, or A indicates the component being dispensed.

INVALID indicates:

1. you pressed an incorrect key,
2. you pressed a key for a function that is not active, or
3. you are not in the right mode for this key to operate.

PASSWORD is displayed when you press the "*" key from the normal mode. Enter "11111" for MANUAL mode or "22222" for PROGRAM mode or enter your own password number if you have established one.

SETTING, OPERATE, TIMED, and CALIBRATE are displayed when the respective keys are pressed from the manual or program modes. These displays are followed by pressing a device key; REG, NAT, COL, ADD, DUMP, ALARM, MIX, or HOLD.

FLASHING means that retries are occurring because the first dispense was not enough. Other error conditions also cause flashing.

ROM OK or ROM BAD indicates condition of ROM chip. See KEYPAD, *25 for explanation.

10. LED LIGHTS

The LED lights in two vertical columns of eight located above the 8 character display indicate the following:

LEFT COLUMN:

1. REG Regrind dump solenoid operating.
2. NAT Natural dump solenoid operating.
3. COL Color drive relay operating.
4. ADD Additive drive relay operating.
5. DMP Dump valve solenoid operating.
6. ALM Alarm output operating.
7. MIX Mixer motor drive relay operating.
8. HLD Mixer flow valve is open (Optional).

RIGHT COLUMN:

ALARMS

1. Alarm is on because Regrind ran out.
2. Alarm is on because Natural ran out.
3. Alarm is on because Color ran out.
4. Alarm is on because Additive ran out.
5. Alarm is on because Weigh bin is not within limits.

6. C Color thumbwheel switches are locked out and the setting being used does not match the thumbwheel setting.
7. A Additive thumbwheel switches are locked out and the setting being used does not match the thumbwheel setting.
8. R Regrind thumbwheel switches are locked out and the setting being used does not match the thumbwheel setting.

11. STROBE LIGHT AND BEEPER ALARMS

The Strobe light flashes and the Beeper sounds when NATURAL, COLOR, or ADDITIVE fail to meter properly. Alarms begin after a preset number of retries have occurred. The number of retries before Alarm is determined by settings in the parameter table (see parameters _AL). Regrind can also be alarmed.

12. ALARM SILENCE

This button stops the STROBE and BEEPER ALARMS. The continuation of the cycle to its proper completion will also stop the alarm. If the BATCH mode is in operation, this button starts the next batch.

13. LEVEL SENSOR input

The high level sensor in the mixing chamber plugs into this outlet and signals the controller to start a dispense cycle when it is uncovered. The sensor must be uncovered for at least 2 seconds before a cycle will start. (see DLY 00488) parameter). Once a dispense cycle is started, covering the sensor does not stop it. Operation continues until the cycle is complete.

14. MIXER MOTOR OUTLET

This outlet is energized continuously when the MIXER SWITCH is ON (up). In the TIMED position, it stays energized for a time period following the dump of the weigh bin. You may adjust this time in the parameter table (MIX 03010). This time should be just long enough to provide adequate mixing. Mixing for a longer period may contribute to a static problem. Also, excessive mixing sometimes causes separation of pellets of different size and weight.

15. MIXER MOTOR ON/OFF/TIMED SWITCH

The ON/OFF switch is provided as a safety so you may switch the mixer off when you wish to clean out the mix chamber. In the UP position (ON), the mixer runs continuously. In the middle position (OFF) the mixer is off. In the down position (TIMED), the mixer will run for a timed period following the dump of the weigh bin.

16. MIXER MOTOR FUSE

This fuse is rated at 3 amps and protects the mixer motor circuit separately from all other fuses. On 100, 200, and 400 series models, this fuse protects the mix motor directly. On 900 and 1800 series models, this circuit operates a 25 amp solid state relay in a separate box. These larger mix motors are protected by a "motor starter" switch with a "heater", which must be on for the motor to operate.

17. LOAD CELL input port

The system's two load cells are joined by a common connector that is plugged into this port.

18. PRINTER output

This is a parallel printer port. A printer plugged in here allows four types of information to be ported directly to a printer giving the benefit of a permanent printed record. They are:

1. The totals of the material usage data.
(press VIEW and "*" keys to print once; or use the PRT parameter to AUTOMATICALLY and periodically print these totals)
2. A listing of the internal parameter table.
(press *77 in the PROGRAM mode.)
3. A printout of information after each cycle including actual dispensed weights and percentages for every cycle.
(press *54 in the PROGRAM mode, use "*" to set printer flag ON.)
4. A printout of information after the TIME or CALIBRATE routines.

Any common parallel printer that you would use with a small PC computer may be used. Connect using a standard parallel printer connecting cable, (34 pin parallel centronix connector to a DB25 IBM compatible connector), available from us or at any computer store. There is a detailed explanation of this printout in the PRINTED OUTPUTS section of this manual.

19. COMPUTER input / output

If you choose to gather material usage data automatically and continuously by computer, this connector allows for connection to an IBM PC type computer operating under MS-DOS or WINDOWS.

The COMPUTER port is a DB9 (9 pin) male port. You will need a specially wired cable from us to connect to the serial output on your standard PC computer. You will also need software from us for communicating with your Weigh Scale Blender. Your computer operating system must be MS-DOS or WINDOWS. This software allows downloading settings and retrieval of information and will produce extensive reports for those customers who wish to take advantage of this feature.

One or many Weigh Scale Blenders can be connected to one computer. Customers that wish to do their own programming may interact with the Weigh Scale Blenders by way of a single program that we provide. This program, when executed, gathers all current totals from all controllers and moves them into an ASCII text file for access by other software.

For multiple Weigh Scale Blender systems, or communication over long distances, an additional piece of hardware is required. All GB/WSB controllers are fully programmed to communicate with your computer now or at a later date.

20. PANEL FUSE for duplex receptacle - 3 amp

Fuses the common power wire of the duplex receptacle (the color and additive outputs). Since these outlets are only turned on one at a time, each is protected to the full 3 amp rating of the fuse.

21. PANEL FUSE for processor - 1/2 amp

Fuses power to the circuit board power supply which includes all solenoid outputs and solid state relay outputs.

22. INTERNAL FUSES

An in-line fuse is provided internally to protect the main 120 volt power cord supply (10) amps. If this fuses blow, an internal short circuit is indicated and we don't recommend that you try to fix it. Remember, this unit carries a five year warranty; just send it back.

The MIX MOTOR timed power source and the AUGER FEEDER OUTLETS are driven by internal solid state plug-in relays. These relays are located on the circuit board mounted on the inside back surface of the controller enclosure. A small 5 amp glass fuse is located to the right of each relay. A spare fuse is also located on the board if replacement is necessary.

23. KEYPAD

The KEYPAD is explained extensively in the next section, next page.

Detailed explanations are given on the pages that follow.

AUTOMATIC OPERATION MODE: (normal operation on power up)
These keys are operational in this mode.

VIEW: View Data: date, time, cycles, and lbs of Reg, Nat, Col, Add.
Press VIEW,* to print all data. At end press 00 to clear data.
RCP: Enter and retrieve stored RECIPES.
BTCH: Blend a preset weight, fill a container and stop. View/Enter
Target Wt., Cur. Portion, Total, Batch Count. CE=clear
FAST: Increase Output. Run rapid FAST cycles after a weighed cycle.
Press * to toggle this function on or off.
TAG: Tag a Work Order and Operator number to all reports.
EXIT: Operational in ALL MODES. Press to EXIT any and all sequences.
CE: Press to display the "raw signal" weight readout for 3 seconds.

MANUAL MODE: to enter press: "*" then (11111) or your own password.
These additional keys are operational.

SET: Observe current settings, set by thumbwheel or keypad.
OPER: Operate all devices manually; open and close valves.
TIME: Operate devices for a timed period.
CAL: Operate devices for a preset time period to learn the rate.
NOTE: With above four keys also press one DEVICE key:
NAT, REG, COL, ADD, DUMP, ALARM, MIX, or HOLD.
ZERO: Zero the tare weight with the bin empty.
FULL: With bin loaded, enter gram weight to calibrate load cells.

*00 Clear DATA fields.
*99 Enable calibration of load cells.

PROGRAM MODE: to enter press: "*" then (22222) or your own password.
MANUAL operations plus these additional keys are operational.

SET: Enter settings using keypad; locks out thumbwheel use.
PARA: View or change system constants and parameters.

STAR FUNCTIONS: Press * and two numbers for the following functions:

| | |
|-----------------------------------|-----------------------------------|
| *02 Extrusion and Yield Control. | *66 GB/WSB I.D. number (1-255). |
| *05 Inhibit table clearing. | *69 Regrind as second natural. |
| *11 DATE - TIME, real-time clock. | *71 Color percent of blend. |
| *12 Move table from ROM to RAM. | *72 Additive percent of blend. |
| *23 Move from RAM to EEPROM. | *74 Stop, alarm MAX wt exceeded. |
| *32 Move from EEPROM to RAM. | *75 Alarm on weight drop. |
| *25 ROM OK flag, "CE" to clear. | *77 Print parameters. |
| *33 Special Alarms. | *78 Change program mode PASSWORD. |
| *44 End cycle - bin full. | *82 Precision Ratioing. |
| *45 Change MANUAL mode password. | *87 VOLUMETRIC operation. |
| *47 Totalizer flag. | *88 Print display readout. |
| *52 Double dump weigh bin. | *89 Select pounds, kilos. |
| *54 Print cycle information. | *98 Display raw weight number. |
| *57 For Liquid Color PIAD system | |

Use "*" key to select readout or toggle flags ON or OFF.

Three (3) operation Modes are available; AUTOMATIC, MANUAL, PROGRAM.

KEYPAD - AUTOMATIC OPERATION MODE

This is the NORMAL operating mode. When power is turned on, the unit is in this mode. Automatic dispensing occurs ONLY in this mode. The AUTOMATIC mode is indicated by the ABSENCE of the letter "P" or "M" at the left end of the display.

Only the VIEW, RECIPE, BATCH, FAST, TAG, *, CE, and EXIT keys are available in this mode.

These keys operate BETWEEN cycles only or when the PAUSE switch is on. To stop between cycles, use the "OFF AT END OF CYCLE" switch.

VIEW DATA: Press to display the CURRENT Date and Time, LAST CLEARED (VIEW) date and time, and stored material usage data. Six totals are available: (in Pounds, Kilos, Grams, or Ounces)

| | |
|--|-------------|
| Number of CYCLES that have occurred: | (CY= #####) |
| Weight of REGRIND that has been dispensed: | (R = #####) |
| Weight of NATURAL: | (N = #####) |
| Weight of COLOR: | (C = #####) |
| Weight of ADDITIVE: | (A = #####) |
| Total weight of ALL materials: | (T = #####) |

Each successive press of the VIEW key displays the next total. The last displayed line will say (00=CLEAR) for 5 seconds. During this time, you may press 0,0 to clear the data. Waiting 5 seconds or pressing any other key will exit the sequence. When the sequence is exited, normal automatic operation resumes. These totals may be displayed as pounds, grams, kilograms, or ounces by a selection procedure explained later (*89).

Press the VIEW key once followed by the "*" key to cause all information to be sent to the printer (if available). To then clear the data, press 00 within 5 seconds. Press any other key or, wait 5 seconds, to continue the process without clearing the totals.

RECIPE: This key allows you to LOOK at, RUN, and SAVE RECIPES.
(RCP) To SAVE a recipe you must be in the PROGRAM mode. Recipes are thumbwheel switch settings. 100 recipes may be stored, numbered 00 to 99.

This key is NOT FUNCTIONAL unless the 3rd digit of the "FLG" parameter is set to 1 (xx1xx). To do this, see the SOFTWARE MAINTENANCE section, PARAMETER TABLE, "FLG".

In normal Automatic mode: Press RCP key. If no RECIPE is currently in use, display says (GET ___). If a RECIPE is currently in use then display will flash through the current stored data:

(RCP ___), (R = xx), (C = xx.x), (A = xx.x)

Press CE to CLEAR CURRENT RECIPE and return to thumbwheels.

Press RCP to look at another recipe. Display = (GET ___).
Enter 2 digits to retrieve one of 99 recipes.
Display will flash through the current stored data:
(RCP ___), (R = xx), (C = xx.x), (A = xx.x), (*TO LOAD)

Press * to LOAD this recipe into memory.

Routine will exit automatically.
Press RCP or EXIT to return to the display (GET ___).
Press RCP or EXIT again to exit.

To SAVE a RECIPE you must be in the PROGRAM mode.
If you press RCP key again after display of (GET ___),
display says (SAVE ___). Enter 2 digits, display will say
(SAVING). The current settings are saved into memory
under the recipe number you have entered. These are
normally the THUMBWHEEL switch settings.

CAUTION: If settings have been entered by KEYPAD or RECIPE,
then these are the ones that will be saved. Therefore, when
saving a recipe, be certain that no other recipe is
currently loaded, and that no keypad-entered settings are
currently loaded. The lower right corner of 3 LEDs should
be off indicating thumbwheels are being read.

To clear a stored recipe, set all thumbwheel switches to
zero and enter these zero settings into the recipe location.

Routine will EXIT automatically.
EXIT will exit at any time.

When a RECIPE is loaded, three LEDs, (R, C, A, Locked
out) light indicating that the thumbwheel settings do not
represent the settings that are being run by the controller.
Whenever internally stored settings are not the same as the
thumbwheel settings, these three LEDs light to indicate this
condition. These LEDs correspond to REGRIND, COLOR, and
ADDITIVE settings respectively.

NOTE: To allow the operator the ability to stop running any
single component, a thumbwheel setting of all ZEROS (00.0)
can be accepted as valid to override any setting entered by
a Recipe. If you want this override option, enter a 0
(_SE 0xxxx) as the first digit in the SE parameter. The
default entry of 1 (_SE 1xxxx) indicates the override option
is turned off. See PARAMETERS; SE.

BATCH: This key allows you to blend a PRE-SELECTED WEIGHT of
(BTCH) material, and then STOP running and sound the ALARM. The
process may also be programmed to sound the alarm but
continue running. Since each cycle will always blend a full
weigh bin amount, the total amount blended may exceed the
target batch weight by up to one cycle's blend weight.

This key is NOT FUNCTIONAL unless the last digit of the
"FLG" parameter is set to 1 or 2 (xxxx1). To do this, see
the SOFTWARE MAINTENANCE section, PARAMETER TABLE, "FLG".

The ALARM SILENCE button on the side of the controller, is

the ONLY way to CONTINUE OPERATION after a BATCH amount has been run.

Assuming a proper "FLG" parameter is set:

Press the BTCH key once to view the desired BATCH WEIGHT.

Display will say (BW #####).

BATCH WEIGHT is the amount you wish to dispense before stopping and/or sounding the alarm.

Press again to view the CURRENT PORTION, of the batch, that has been dispensed.

Display will say (CP #####).

CURRENT PORTION shows how much has been blended so far.

Press again to view the ACCUMULATED TOTAL weight of all batches dispensed.

Display will say (AT #####).

ACCUMULATED TOTAL is the sum weight of all batches that have been blended. This number will continue to grow until it is manually cleared to zero, or it exceeds its maximum possible value.

Press again to view the total BATCH COUNT.

Display will say (BC #####).

BATCH COUNT is the total number of batches that have run. This number will continue to grow until it is manually cleared to zero, or it exceeds its maximum possible value.

Press again to return to normal operation.

When any of the above totals are being displayed, you may press the CE key to RESET that number to zero. While all four totals can be cleared to zero manually, only a BATCH WEIGHT number can be entered manually.

When the BATCH WEIGHT is being displayed, you may enter a NEW batch weight using the keypad. You must enter a 5 digit number with leading zeros, if necessary. Maximum number that can be entered is "59999".

The unit of weight that will be used is either POUNDS or KILOGRAMS as determined by the *89 option, explained later.

While in operation, when the total is reached or exceeded, the system will alarm and stop blending if the FLG parameter is set to 00001. The system will alarm but CONTINUE running if the FLG parameter is set to 00002.

Use the ALARM SILENCE button (on the side of the controller) to silence the alarm. Pressing the BTCH key to view the information will also silence the alarm.

If the system is programmed to STOP at the end of a batch, the ALARM SILENCE button MUST be pressed to start blending the next batch. The First press of the ALARM SILENCE button will silence the alarm. The Second press will start the next batch.

NOTE: Fractional cycles are not blended. Total weight may be in over the target by as much as one cycle weight.

The EXIT key will exit the BTCH sequence at any point but will NOT cause the system to start a new batch.

If an additional 120 volt output is desired for an alarm, substitute a 4 or 7 for the 00001. 4 turns on the Additive outlet, 7 turns on component 7 output.

If you have a printer connected, totals will print automatically. (see VIEW, * for details).

FAST: This key will allow you to exceed the normal blending rate of your unit. Once your system has learned proper flow rates of each material, the timing of each component dispense is very consistent cycle to cycle. The FAST key allows one or more FAST REPEAT cycles to follow a normal calibrated cycle. In a FAST REPEAT cycle all components are dispensed simultaneously, without any weights being taken. Errors in dispense amounts will not be detected. These are, in fact, volumetric dispenses, not gravimetric. These dispenses take much less time. Throughput may be doubled in this manner.

This key is NOT FUNCTIONAL unless the 4th digit of the "FLG" parameter is set to 1 (xxx1x). To do this, see the SOFTWARE MAINTENANCE section, PARAMETER TABLE, "FLG".

The shorter mixing time may be a problem. So the number of FAST REPEAT cycles is kept as low as possible. Up to 4 repeats may occur.

After pressing the FAST key, use the * key to toggle the FAST flag ON of OFF. When set to (FAST OFF) FAST mode will not operate. When set (FAST ON) every normal calibrated dispense will be followed by up to 4 FAST repeat dispenses.

Press * to toggle between (FAST ON) and (FAST OFF).
Press EXIT, to exit.

When the FAST mode is in operation, the display (FAST) will flash intermittently.

TAG: This key (third row, third key) allows three pieces of information to be "tagged" onto all data that is either printed or retrieved through the computer port. The items are WORK ORDER, OPERATOR, and RECIPE number.

This key is NOT FUNCTIONAL unless the 2nd digit of the "FLG" parameter is set to 1 (xlxxx). To do this, see the SOFTWARE MAINTENANCE section, PARAMETER TABLE, "FLG".

Press once to display the current Work Order number (WO-----). Press again to display the current Operator number (OPRTR---). Press again for the Recipe (RECP ---). You may enter or change the Work Order or Operator number when each is displayed. Recipe number can not be altered.

These numbers are for your TRACKING of information ONLY. They have NO EFFECT on the operation of the Weigh Scale Blender.

WORK ORDER number (6 digits) allows you to tag all information with an internal accounting number such as a job or purchase order number.

OPERATOR number (3 digits) allows you to track who is operating the equipment.

RECIPE number (3 digits) allows you to track what recipe you are using. The number will be a 2 digit number if a recipe is being run that resides in the controller RAM; one that was entered using the RECIPE key. If a recipe has been enter using our MLAN software, through the computer port, then a 3 digit number will be displayed. In any case, the number in this field will be displayed and "tagged" to all printouts and retrievals.

EXIT will exit the sequence at any point.

EXIT: Operational in ALL MODES to exit ALL keypad sequences.

CE: Press "CE" at any time to display RAW DATA readout of the load cells for five seconds. This is helpful in diagnosing possible load cell problems and is explained in detail in the MAINTENANCE section.

Holding the "CE" key down while turning POWER ON will perform a "CLEAR". See CLEAR ROUTINES section.

V/T and UP/DOWN ARROWS: Operate in the Extrusion Control Mode only. Refer to Extrusion Control Supplement for their operation.

KEYPAD - MANUAL MODE

In this mode, you may operate individual functions manually for test purposes. Calibration of Load Cells is also possible. No totals are saved and automatic operation does not take place. The low level sensor has no control or effect over manual operation requests.

The Row of keys marked SET, OPER, TIME, and CAL operate in this mode coupled with the Column of keys marked REG, NAT, COL, ADD, DMP, ALRM, MIX, and HOLD. ZERO and FULL keys allow Load Cell calibration.

You can enter this mode only when the controller is between cycles. The sensor must be covered or the sensor control switch must be in the "STOP - END OF CYCLE" position. When in this mode, no automatic dispensing occurs.

TO ENTER THIS MODE: press "*", then enter the correct password number. The correct password supplied with the unit is "11111." You may change this to any other 5 digit number if you wish as explained later (*45). When in the MANUAL mode, the letter "M" shows at the left end of the display.

The following manual functions are available in the MANUAL mode.

SETTING: Press once followed by one of 3 keys: REG, COL, or ADD. The
(SET) current thumbwheel setting is displayed. If, while in the
program mode, the keypad was used to enter this setting then
it will not match the thumbwheel setting.
EXIT will exit the sequence.

OPERATE: Press once followed by one of 8 keys: REG, NAT, COL, ADD,
(OPER) DUP, ALM, MIX, or HOLD. The selected output operates until
the key is pressed again or another output is selected.
Only 1 output will be active at a time.
EXIT will exit the sequence and close all outputs.

TIMED: Press once followed by one of 4 keys: REG, NAT, COL, or
(TIME) ADD. A time in interrupts is requested; (TIME ---). Three
digits must be entered specifying a dispense time up to 999
interrupts (about 4 seconds max.). CE will cancel entry
before last digit is entered. Following a full 3 digit time
entry, the specified output is activated for the time
requested. After the dispense is weighed, the dump valve
automatically operates to empty the weigh bin. If a printer
is on line and the Print flag is ON, then output information
will be printed. EXIT will exit the sequence.

CALIBRATE: (RATE) Press once and then press one of 4 keys: REG, NAT,
(CAL) COL, or ADD. A dispense will occur for 2 seconds. If the
amount dispensed is less than 50 grams, a second dispense
will occur for 20 seconds. Using the resulting weight and
time, the processor calculates a proper beginning point dump
rate for the start of production blending. After each
dispense is weighed, the weigh bin dump valve automatically
operates to empty the weigh bin. If a printer is on line
and the Print flag is ON (see KEYPAD *54), then output
information will be printed. EXIT will exit the sequence.

If the display says (DO AGAIN), press any key to cause the
process to repeat itself. If the display then says
(NO GOOD), the weight dispensed was below 5 grams, not
enough for a valid calibration.

During initial operation, after each power up, the blender
calibrates itself completely automatically, regardless of
how far off the initial flow rate may be. This may take
several cycles. During normal operation, calibration
correction occurs continuously.

Since this unit adjusts flow rates automatically, manual
Rate Calibration is not necessary for proper operation.

ZERO WT: THIS HAS BEEN DONE AT THE FACTORY. IT SHOULD NOT BE
(ZERO) NECESSARY FOR YOU TO DO THIS AGAIN.

Press the ZERO key once to set the displayed gram weight of
the empty bin to zero. BE SURE the load cells are plugged
into the controller. Be sure the bin is properly in place
and EMPTY when this key is pressed.

For this key to function, you must first set the weight calibration flag ON. Press *99 to observe flag status. Press * to toggle flag ON or OFF. With flag set ON, press EXIT. Power-off always resets this flag to OFF.

Since the bin, even when empty, weighs about 1300 grams, it is necessary on initial setup of equipment to instruct the controller of the exact tare weight of the empty bin.

Slight drift in the tare or zero weight during day to day operation is normal. All weight calculations automatically compensate for this drift. However, when the bin is empty, if the weight displayed is more than 50 grams above or below zero, then you may wish to reset the electronics to display zero when the bin is empty.

If, when the bin is empty, the weight displayed is greater than 100, or less than -50, (Parameters TH and TL), the dispense cycle will not begin. Instead, the dump valve will repeatedly try to dump any material it thinks is in the bin or will sound the alarm if weight is below -50. If the load cell calibrations have drifted this far, it is absolutely necessary to reset empty bin weight to zero.

If weight readings drift steadily in one direction, allow system to warm up before setting ZERO or FULL weights.

Generally, when zero weight shifts, full weight reading shifts the same amount. Since resetting ZERO WT automatically shifts FULL WT the same amount, resetting ZERO weight usually is all that is necessary to correct both ZERO and FULL weights.

FULL WT: THIS HAS BEEN DONE AT THE FACTORY. IT SHOULD NOT BE
(FULL) NECESSARY FOR YOU TO DO THIS AGAIN.

ZERO WT. must be entered before FULL WT. to achieve proper calibration. The FULL WT. key will not function until you have set ZERO WT. as described above.

If you wish to reset the controller for proper full-weight scale display, use any known weight as close to design full weight as possible (1000, 2000, 4000, or 9000 grams). For 18000 gram systems, use 9000 grams. Place this weight in the bin and press the FULL WT. key. The display will show five dashes (FULL_____). Now enter the actual weight, in grams, of the item you are weighing.

AGAIN, both FULL WT. and ZERO WT. have been set at the factory. A drift of several grams from these settings is normal and should not be of any concern. Recalibration should be considered only if ZERO is more than 20 grams off or FULL WT. is more than 50 grams off. These errors do not prevent proper proportions from being dispensed. ZERO error is always "tared" for proper weighing of each component. FULL scale error will only cause accumulated totals to be off by the degree of this error. The primary function of

the WEIGH SCALE BLENDER is to dispense materials in the proper ratios. Because all components are weighed by the same load cells, the accuracy of these ratios is not affected by zero or full scale errors.

STAR FUNCTIONS available in this mode.

00 Press (,0,0) to CLEAR ALL DATA fields. These are the material usage totals that are viewed with the VIEW key. If you are tracking material usage WITHOUT a computer, you may wish to reset them to zero on a regular basis for simplicity of calculations. If you are using a computer to gather and track totals, DO NOT clear these totals. The computer software will most likely loose data if you do.

After VIEWING the data or printing the data using the VIEW,* key sequence, a display of (00=CLEAR) will appear for 5 seconds. During this 5 seconds you may reset all data fields to zero by pressing 00. Pressing any other key will exit this sequence without clearing data.

99 Press (,9,9) to set flag to enable Weight Calibration of the Load Cells. This flag must be ON before the load cell weight calibration keys, ZERO and FULL WT, will function.

Use the * key to toggle flag ON or OFF.
Power On will always set this flag to OFF.
Press EXIT when desired flag status is displayed.

KEYPAD - PROGRAM MODE

In this mode, you may perform ALL of the functions available in MANUAL mode, plus additional functions that alters the logic with which the controller operates.

The PARA (PARAMETER) key operates in this mode.
The SET key has additional functions.
STAR FUNCTIONS are available by pressing the * key and two numbers.

Just as with the MANUAL mode, you can enter this mode only when the controller is between cycles. The sensor must be covered or the sensor control switch must be in the "STOP - END OF CYCLE" position. When in this mode, no automatic dispensing will occur.

TO ENTER THIS MODE: press "*", then enter the correct password number. The correct password supplied with the unit is "22222". To change this to another 5 digit number of your choice, see (*78). When in the PROGRAM mode, the letter "P" shows at the left end of the display.

The following PROGRAM functions are available in the PROGRAM mode.

SETTING: Press the SET key once followed by one of 3 keys: REG, COL, or ADD. The current thumbwheel setting will be displayed. (SET) If the keypad, or a computer, was used to enter this setting then it may not match the thumbwheel setting.

A new setting may be entered at this time by keypad if so desired. (CE will cancel entry before last digit is entered.) Settings entered by keypad CAN NOT BE ALTERED by the thumbwheel switches. After entering a setting by keypad, verify this by rotating the appropriate thumbwheel switches. An LED will light indicating that the internal setting being used by the computer does not match the thumbwheel switches.

The display of a setting followed by pressing the "CE" key, will revert that setting back to thumbwheel control and will also exit the sequence. EXIT will exit the sequence.

This function will positively fix the settings so that thumbwheel switches have no control and no one can change them without authorization. An LED will light indicating this override condition. The LED will be lit ONLY when the thumbwheel setting does not match the internal setting.

To allow the operator the ability to stop running this component, a setting of all ZEROS (00.0) is still accepted as valid and will override any setting that has been entered by keypad. If you do not want this override option, enter a 1 as the first digit in the SE parameter. See PARAMETERS, _SE.

To later return to thumbwheel control, use the same procedure as above except instead of entering a setting, press the "CE" key when you see the setting displayed.

PARAMETERS: Press the PARA key to display the table of operating (PARA) parameters that reside in memory. There are more than 60 parameters, and each successive press of the key displays the next parameter in the table. Pressing the "*" key allows you to back-up in the table. You may change a parameter by entering a new number over the old one. CE will cancel a number entry before the last digit is entered. All parameters are fully explained several pages forward in this manual. EXIT will exit the sequence.

STAR FUNCTIONS.

*02 This flag for EXTRUSION and YIELD control.

Press (*,0,2) to turn on Extrusion or Yield control. The default display is (OFF). Press * to toggle this flag to (RATE), (EXT CTRL), or (YLD CTRL).

If you are using our EXTRUSION or YIELD control software to control your extruder, refer to our EXTRUSION CONTROL instruction booklet for complete information.

If you simply want to view throughput continuously on the blender display, set this option to (RATE). This will

alter the display only. In all other respects, the blender will operate normally.

05 Press (,0,5) to inhibit the (00=CLEAR) display at the end of the VIEW sequence. Customers using MLAN or G2 software for retrieval of material usage information, may wish to restrict an operators ability to clear the material usage data at the controller. This option allows you to remove the floor operators ability to clear this data. Press * to toggle between (CLEAROFF) and (CLEAR ON).

11 Press (,1,1) to enter the correct date and time into the real-time clock. Correct date and time is helpful if you are retrieving information using a printer or are collecting data by computer. Six entries will be requested.

The first display will indicate USA or EUROPE date format. USA will cause all dates to be displayed MONTH/DAY/YEAR. EUROPE will cause all dates to display DAY/MONTH/YEAR. Use the CE key to toggle from one to the other.

The remaining five entries are two digits each;
MONTH __, DAY __, YEAR __, HOUR __, MIN __.

Use the * key to step through all displays without change. enter new settings where required. The correct date and time have been entered at the factory and should never have to be reset. Of course you may be in a different time zone.

12 Press (,1,2) to move the PARAMETER table from ROM to RAM. This allows system to operate with the parameters that were originally supplied as default numbers with the system.

EXPLANATION: All PARAMETERS are stored in a table that resides in three places: ROM, RAM, and EEPROM.

ROM stands for "Read Only Memory." This memory portion of the circuit board cannot be altered in any way except by physically replacing this chip on the board. It contains the program and the copy of the parameter table that we supply as standard with all controllers.

EEPROM stands for "Electrically Eraseable Programmable Read Only Memory." This memory portion of the circuit board can be altered by the computer by special request only, and data stored here is not lost even if the battery backed up RAM should lose power. It contains all parameters and control numbers that are unique to your system. At the factory we have set what we believe to be the proper parameters for your application into the EEPROM.

RAM stands for "Random Access Memory." It is the memory portion of the circuit board that would go blank if power were removed from it. We have provided a battery back-up for the RAM so this should never be a problem. On normal power off and power on, the data and parameters that reside in RAM are not lost. However, RAM is the portion of memory most easily corrupted due to unforeseen circumstances in the

poor electrical environment of a factory. Should some unforeseen circumstances cause the data in RAM to be corrupted or lost, a CLEAR-RESTART procedure is provided that will retrieve the parameter table stored in the EEPROM and copy it into RAM memory for use. If you make changes to the PARAMETER table, these changes reside only in RAM and may be lost in the event of an unforeseen computer malfunction. To insure that your changes are saved for future runs, it is necessary to move this information from RAM to the EEPROM.

NOTE: The battery used for backup is a lithium battery that is part of an I.C. chip on the board. It has an expected 10 year life and is not easily accessible for replacement. Should it fail, we suggest that it be replaced at our factory.

- *23 Press (*,2,3) to move the PARAMETER table from RAM to EEPROM. This information is then available for retrieval using the CLEAR routine (press CE key on Power Up) or by using the *32 function described next.
- *32 Press (*,3,2) to move EEPROM information to RAM. This is useful for retrieving correct information that you may have stored earlier in the EEPROM. Also, if you have been making changes to RAM tables and now wish to restore all parameters to what they were at power up, this is the function to use.
- *25 Press (*,2,5) to check the ROM-CHECK flag. Whenever your controller is on, the processor is continuously performing an integrity check of the ROM program chip supplied with the unit. Each complete scan of the program takes about one minute. If any single check reveals an incorrectly set bit, the ROM CHECK flag is turned on. This flag is checked every time you power up. If the flag has been set the display will say (ROM BAD), followed by the date and time of the last check that was found bad. If the flag has not been set, (ROM OK) will be displayed. To turn the flag off, you must select this option, (*25), and, with (ROM BAD) displayed, press the "CE" key. This will clear the flag and it will remain off until another error is detected. The seriousness of the problem will be somewhat indicated by the date and time of the last bad check and how frequently you find it necessary to turn this flag off. Even with an error, your controller may still work perfectly. However, we suggest you request a new program chip from us as soon as possible.
- *33 Press (*,3,3,) to turn on a special alarm condition. Press * to toggle between (AL STD) and (AL-BATCH). If you are running using the BATCH key, and (AL-BATCH) is selected, then the ALARM will sound when a batch is completed.
- *44 This flag for SPECIAL APPLICATIONS ONLY.

Press (*,4,4) to tell the controller to end a cycle when the weigh bin is FULL. Use the * key to toggle between (END EMTY) or (END FULL).

Normal operation is to end the cycle EMPTY. The (END FULL) option is ONLY for SPECIAL installations where the sensor has been relocated BELOW the mix chamber and the purpose of the unit is to calculate exact material usage rates in order to control an extruder.

Leave this flag set to (END EMTY), unless you have specific instructions to do otherwise.

45 Press (,4,5, followed by a 5 digit number) to change the PASSWORD number for entering the MANUAL mode. The system is supplied with the number "11111" as the password number. If you wish to restrict use of this mode to only yourself, you may make up your own number and enter it here.

*47 This flag is for GT (totalizer) models only.

When set, the display will continuously display the total amount of material that has passed through the unit since the total fields were last cleared. When the unit is functioning as a totalizer, this is the information that is most meaningful.

Press (*,4,7) to turn the totalizer functions on.
The display will say (TOTL OFF).
Press "*" to toggle flag to (TOTAL ON)

To RESET TOTALS to zero:

1. Stop operation by switching to "STOP END OF CYCLE".
2. Move the pause switch to "IMMEDIATE PAUSE".
3. Press the "ALARM SILENCE" button.

This will clear the totals.

52 Press (,5,2) to cause the weigh bin dump valve to operate two times. We call this a "double dump". If you have problems with material hanging up in the weigh pan, this may help shake it loose.

Use the * key to toggle between (DBLD OFF and (DBLD ON).
Press EXIT when done.

54 Press (,5,4) to set flag for a printout of data after each full dispense cycle. With this flag ON and with a printer on line, four lines of information about the dispense cycle that just occurred will be sent to the printer. This information includes dispense weight and percentage of each component, the internal rate numbers used by the computer to determine dispense time, and the actual dispense time of each component. This is excellent information to track the accuracy of each dispense cycle and the accuracy of the entire system over an extended period of time. A more detailed explanation of this information is in the PRINTER OUTPUT section of this manual.

Use the * key to toggle flag ON or OFF.
Press EXIT when done.

*57 For LIQUID COLOR applications only. This function usually operates in conjunction with an additional two air solenoids mounted on the blender frame.

Press (*,5,7) to allow automatic switch over to a full drum when the current drum of color runs out. When function is off, display will say (COL= 4). Press * to toggle to (COL= 4+7). When display says (COL= 4), the color setting applies to output 4 only, the standard COLOR output. When display says (COL= 4+7), this means that output 4 is the starting output, and when no weight is detected after a dispense, the output switches to output 7. The "7" is determined by the parameter (LIQ 00007). You can change the secondary output by changing the parameter.

If output 7 is also empty, the output switches back to 4. See parameter (LIQ 00007) for more information.

66 Press (,6,6) to enter an identification number for this particular weigh scale blender. This I.D. number will appear on all printed reports. If you have more than one unit, this helps to identify reports. If you are using a computer to automatically gather data, then each controller must have a unique address. Valid numbers are 000 to 255. They need not be consecutive. When units are connected to a computer, do not use the number 000 for identification.

69 Press (,6,9) to set flag to treat the "REGRIND" dispense as a SECOND NATURAL material.

With the flag OFF, Natural is calculated to fill the space remaining in the weigh bin after a Regrind dispense has occurred. In other words, when a reduced amount of Regrind is dispensed, additional Natural is dispensed. Color and Additive dispenses are calculated as a percentage of this Natural dispense ONLY.

With the flag ON, Natural is calculated to maintain the proper RATIO between the two components (Natural and Regrind). Color and Additive dispenses are calculated to add to BOTH components at the requested ratios.

"Regrind", in the normal sense, is not added. Instead, this component is treated as another "Natural" material. If the ratio of the two naturals is not 50/50, place the HIGHER volume component in the "regrind" side. Set the "regrind" thumbwheel for the percentage that the "regrind" side is of the combined mix. For example; Naturals A and B are to be used at a 20/80 mix ratio; B is the greater at 80 percent. Put component B in the regrind side and set the regrind switch for 80 percent.

NOTE: The Regrind alarm parameter (RAL) is automatically set to a number that forces retries and stops the system when this component runs out. See PARAMETERS, RAL-00004.

Use the * key to toggle flag ON or OFF.
Press EXIT when desired flag status is displayed.

NOTE: Do not use these features in combination with *82.

*71 and *72 This flag for SPECIAL APPLICATIONS ONLY.

Press (*,7,1) to change the Color setting to be interpreted as percent of the entire MIX instead of percent of the Natural. Press (*,7,2) to change the Additive setting in the same way.

The display will say (CPM -OFF) or (APM -OFF). Press "*" to toggle flag to (CPM -ON) or (APM -ON). (CPM stands for Color Percent of Mix, APM for Additive Percent of Mix). These options has been added for a customer with a unique requirement.

Leave these flags OFF unless you have specific instructions to do otherwise.

CAUTION: With flags set, Color and Additive settings combined must NOT exceed 100 percent. From a practical standpoint, they should not exceed 20 percent combined.

74 Press (,7,4) to set a flag that will cause the system to stop and the Alarm to activate when MAX weight is exceeded. This might occur if a valve sticks open or slightly open. Normally the system recovers automatically from such events with only the one batch blended incorrectly. Set the flag only if you want the system to stop and alarm.

Press * key to toggle between (MAX OK) and (MAX ALARM). Press EXIT when done.

75 Press (,7,5) to set a flag to ALARM if the weigh bin weight drops more them 20 grams during a cycle. This serves to detect and report a weigh bin problem, such as material leaking from the bottom of the bin.

77 Press (,7,7) to print a copy of all internal parameters. A printer must be connected and ready. Four columns will print since parameters reside in four different locations in memory: RAM; ROM, both WSB2 and WSB9 default listings; and EEPROM. Identifying headings print above each columns.

78 Press (,7,8, followed by a 5 digit number) to change the PASSWORD number for entering the PROGRAM mode. The system is supplied with the number "22222" as the password number. If you wish to restrict use of this mode to only yourself, you may make up your own number and enter it here.

If you forget your password number, call us for help.

82 Press (,8,2) to produce a precision ratioing of either the Color or Additive. Press CE (previously *) to toggle between (P/R OFF), (P/R COL) or (P/R ADD).

If precision rationing is selected, the Color (or Additive) dispense occurs BEFORE the Natural, instead of after.

Natural will dispense after the Color (or Additive) dispense and will be calculated to assure the most exact percentage ratio for the selected component. Because the Natural dispense is larger, this method allows for more exact ratioing of the one selected critical component.

NOTE: Do not use this feature in combination with *69.

83 Press (,8,3) to select "Progressive Metering" option. Progressive Metering allows for more accurate dispenses of selected components. However, cycle time will be extended by a few additional seconds.

In normal operation blenders target a dispense of the full requested amount in one try. This almost always works, and generally will fall within acceptable upper and lower error limits. Making the dispense in one try allows for high throughput rates while still achieving a level of accuracy acceptable for most processors. When the accuracy of one particular component is critical, or the process depends on maintaining a tighter tolerance of this component, customers may lengthen the blend cycle time slightly to achieve this higher level of accuracy.

The *83 function is used to turn on the progressive metering function for a selected component. This sets parameters which will cause the dispense to occur in several progressively smaller dispenses. This results in a more accurate dispense.

The first dispense targets only 85 percent (the default percentage) of the full required amount. After careful weighing, each successive dispense targets 50 percent of the remaining shortage. This continues until the amount reaches, or is within 1 percent of, the target. In this manner the software "sneaks up" on the target, providing the maximum achievable accuracy possible.

When a component is selected and turned ON, the corresponding PT and RP parameters are set to PT 00085 and RP 00001.

The keypad sequence:
Press *,8,3. Display will say (COL OFF).
Use the "*" key to walk through all the components.
Use the "CE" key to toggle a component ON or OFF.
When ON, Display will say (C=ON 85).
You may change the 85 by entering a different number.
Too low will just add time. Too high will cause occasional overshooting.
Press EXIT when done to save new settings.

86 Press (,8,6) to select a new "Back Door" password for your software. Display will say (BDP 00000). Enter 00001 up to 00009 to select one of nine new backdoor passwords. Contact us for the actual number. If you just want to kill the use of a backdoor password altogether, just enter a number from 1 to 9, and don't call us. Then no one in you plant will

know the number. But we still will, just in case. Then your own selected regular password will work and as long as you don't forget it, your ok.

Blenders are pre-programed with two normal passwords; (22222) is the default password for the PROGRAM mode, (11111) is the default password for the MANUAL mode. You can alter these passwords to any 5 digit number, but you must know the current PROGRAM password to change it. If for some reason the password has been altered and you can not remember it, we have a special "backdoor" password that will let you in no matter what. For obvious reasons, we do not provide that password in this manual. You must call us. However, there is a problem. If the wrong person in your factory obtains this password, then he will always have access to the Program mode of the blender no matter what.

Now, with this star function, you have the option to select from 10 different "backdoor" passwords. If your current "backdoor" password is known to the wrong person, you can call us for a new one. We will not give these backup passwords to just anyone. In fact, since only I know them, it is not that easy to obtain these numbers.

To activate a new "backdoor" password, you will enter a number from 00000 to 00009 using this star function. each number activates a different password. entering 0 activates the current backdoor password, the one we have used for over 10 years. For a new one, call us and talk with someone you know here in the office and they will supply a number from 1 to 9, and the associated new "backdoor" password.

After this new "backdoor" password is selected, you can safely change the regular password to one only you know, and use that in normal production. No one will be able to use the backdoor to get in. If you forget your regular password, and you also forget which backdoor password you selected, then we will work with you and go through the entire list to find the one that works.

87 Press (,8,7) to set flag for operation in a VOLUMETRIC mode. With this flag ON (VOLUMETRIC mode), the load cells are completely ignored. Error correction and rate recalibration does not take place. The unit functions like a volumetric feeder without checking or correcting for errors. Since load cell readings are ignored, this flag allows operation even if the load cells become damaged. Dispense times will be based entirely on the WT and TI parameters.

Use the * key to toggle flag ON or OFF.
Power On will always set this flag to OFF.
Press EXIT when desired flag status is displayed.

88 Press (,8,8) to force a documented printout of the display on the controller front. DATE, TIME, Machine number, and display will print:

Date: 11/09/93
Time: 17:22:01
Machine number: 002
Display Readout: P 500.0

This is useful for obtaining printed verification of load cell accuracy to comply with ISO-9000 and British Standards rules.

The recommended procedure is:

1. Place the unit into the Program mode.
2. Press *88 for printout of empty bin TARE weight.
3. Place a KNOWN CERTIFIED WEIGHT into the weight bin.
4. Press *88 again for printout with the weight added.
5. The different between the two weight printouts should equal the KNOWN CERTIFIED WEIGHT.

89 Press (,8,9) to select the desired weight unit (GRAMS, KILOGRAMS, OUNCES, POUNDS) for readout of data. Systems in the U.S.A. are supplied with POUND readout selected. KILOGRAMS is preferred for nearly all countries outside the U.S.A. GRAM or OUNCE readout is appropriate only for very short runs or short demonstrations.

Use the * key to walk through the four possible selections. Press EXIT when the weight unit you want is displayed.

98 Press (,9,8) to set flag for RAW SIGNAL readout in place of gram readout of scale weight. A raw signal readout is useful to demonstrate the extreme sensitivity of the load cells. The raw signal readout bypasses calibration math. Load cell function can be monitored without concern for any improper weight calibration that may have been done.

Use the * key to toggle flag ON or OFF. Power On will always set this flag to OFF. Press EXIT when desired flag status is displayed.

During normal operation, pressing the "CE" key will cause raw signal readout to be displayed for 5 seconds.

PARAMETERS

All WEIGH SCALE BLENDER controllers operate according to certain internal PARAMETERS. Because customer requirements vary widely, we have made over 60 parameters accessible for change through the keypad.

BRIEF explanations are given first. FULL information is given in the section that follows.

NOTE: Values shown here are initial ROM values of a model 220. Initial values for other models are listed at the end of this section.

Parameters are five digits, with leading zeros added.

TIMES are expressed as seconds, minutes, or interrupts.
(244 interrupts = 1 second).

WEIGHTS are always expressed as GRAMS.

100 and 200 models use tenths of grams: (xxxx.x). (00010 = 1 gram)
400, 900, and 1800 models; full grams: (xxxxx). (00050 = 50 grams)

PERCENTS are expressed in tenths for settings (0xxx.x),
and full percents for other percentage references (00xxx).

=====

PARAMETER LIST - BRIEF EXPLANATIONS

FLG 00000 turns on the RECIPE, BATCH, FAST, and TAG keys.

These four keys will NOT WORK unless you set this parameter.
The RECIPE key is for storing up to 99 recipes.
The BATCH key allows for filling a barrel or gaylord.
The FAST key allows a higher output mode.
The TAG key adds certain information to all printouts.

RPO 00000 Pulsed Output, timing of ON/OFF pulses.
NPO 00000 (Reg, Nat, Col, Add).
CPO 00000 Set only for Micro Pulse equipped slide gates.
APO 00000

MPO 00010 Pulsed output to the mixer motor

RAL 00000 Last digit = number of retries before ALARM.
NAL 00004 00001 to 00009 = sound alarm, hold process.
CAL 00004 00011 to 00019 = sound alarm, continue process.
AAL 00004 00000 = no alarm, no retries.

These parameters set ALARM functions.
When material runs out, or does not dispense fully, these flags instruct the controller what to do. Default settings shown are for Natural, Color, and Additive to alarm, but not Re grind.

MIX 00015 MIX TIME

This parameter times how long the MIX motor runs in seconds.

JOG 03030 Mix blade JOG count and interval

This parameter sets how many jogs will occur and how often.

FCV 00006 TIME the Flow Control valve delays before opening (sec.).

This parameter holds each batch in the mix chamber for a time to assure mixing. This is only for units equipped with the optional flow control valve under the mix chamber.

DTI 00006 Weigh bin dump TIME at end of cycle. (seconds)

This parameter sets the maximum open, or dump time for the weigh bin. No change is required.

KDF 00010 Maximum variation in GRAMS between two consecutive weight
WDF 00010 readings for reading to be accepted. (x or x.x)

KDF controls sensitivity of weight readings during calibration of load cells. No change is required.

WDF controls the sensitivity of weight readings during normal operation. If excessive vibration interferes with weight readings you may have to increase this number.

BER 00200 Excess GRAM weight before dispense is aborted.

This parameter controls sensitivity of the emergency "bailout" routine that prevents overfilling of the weigh bin. No change is required.

CXT 00000 Move decimal left on color and additive settings.
AXT 00000

These parameters allow entry of less than (00.1) percent for COLOR or ADDITIVE.

When set to "00010" settings are read as X.XX percent.

When set to "00100" settings are read as .XXX percent.

ROC 00000 These three parameters help control regrind usage.
ROV 00000
RHL 00000

ROC indicates the PERCENT of REGRIND that will be treated as natural when COLOR and ADDITIVE dispenses are calculated. This adds some color or additive to your regrind.

ROV is for closed loop fully automatic reprocessing of regrind scrap. This parameter will detect when more regrind is being produced than consumed, and override the current setting to use a higher amount. This helps prevent material backing up in your grinder.

RHL has effect only if level sensors are added to your unit to detect material level in the regrind hopper. These level sensors can alter regrind percent usage.

FUL 20000 Full batch weight, determined by weigh bin size.
MAX 30000 Maximum GRAM weight the software will target.

FUL is the target weight that is blended each cycle. Change only

for extremely fluffy or very heavy material.
MAX prevents overflowing of the weigh bin. It is reset automatically if the FUL parameter is changed.

TH 01000 The highest and lowest acceptable TARE weights for
TL 00500 blend cycle to start. (full or tenth grams)

TL prevents starting with the weigh bin out of place. No change is required.

TH prevents starting with a full weigh bin. Change TH only if clumps of material hang up in the weigh bin.

PRT 00000 MINUTE interval between automatic print of TOTALS.

This parameter will cause your system to PRINT MATERIAL TOTALS automatically. A printer must be connected.

RSE 01000 Upper SETTING limits for thumbwheels (0xxx.x).
CSE 01000 Settings greater than limit are held to limit.
ASE 01000 "01000" = 100%.
RLO 00050 Lower SETTING limit for REGRIND (0xxx.x).

_SE parameters SET UPPER LIMITS to the thumbwheels. For color and additive, lower settings may help ensure expensive material is not wasted.

RLO sets a LOW limit of 5 percent to the REGRIND setting.

DLY 00488 Delay before cycle start. (interrupts)

This parameter is the time that the sensor must be uncovered before a cycle will begin.

LT1 00000 Loader #1 time. (seconds)
LT2 00000 Loader #2 time.

These are timers for loaders. Since loader outputs are not yet available, leave them set to zero.

RPT 00000 Percent of target to reduce first try dispense.
NPT 00000
CPT 00000
APT 00000

These can increase the accuracy of slow dispense devices ONLY, like augers, and micro pulse valves.

RWT 26000 WT/TI = the rate that will be used for calculating the
RTI 00976 next dispense time.
NWT 26000 WT = the Weight portion of the dispense rate, calculated
NTI 00976 such that WT/TI equals the average of the last two
CWT 10240 actual dispense rates.
CTI 31232 TI = the TIME portion of the dispense rate. (interrupts)
AWT 10240
ATI 31232

These change AUTOMATICALLY during normal operation.
They are Weight and Time portions of the flow rate calibration.

RMI 00001 Minimum valid dump rate GRAMS/sec. (full or tenth grams)
NMI 00001 Error correction is bypassed when dispense rate is lower.
CMI 00001
AMI 00001

On power up, these are always set to 1. After several consistent cycles, they are reset to 80 percent of actual flow rate. These prevent excessive swings in flow rate calculations if material is running out.

RNC 00050 Allowable GRAM error within which NO correction is made.
NNC 00050
CNC 00010
ANC 00010

This is the acceptable error range for each component to prevent hunting. They adjust automatically over an extended time period to match the flow characteristics of each material.

RRP 00010 PERCENT shortage error that will force a retry.
NRP 00010
CRP 00010
ARP 00010
RRD 00500 GRAM weight shortage error that will force a retry.
NRD 00500
CRD 00050
ARD 00050

Both RP and RD limits must be met before system will advance to the next component. Retries occur until both conditions are met.

RLA 00020 Lag TIME before dumping ACTUALLY starts.
NLA 00020 (mechanical response time, interrupts)
CLA 00012
ALA 00012

These parameters state the lag time between when a device is signaled and when it actually begins to operate. Change ONLY if you change to non-standard equipment.

PRC 00010 Maximum allowable PERCENT rate change per cycle.

This prevents excessive swings in flow rates. Do not change.

STL 00244 Dispense settle TIME before a weight reading is taken.

The time (interrupts) allowed for material to SETTLE in the weigh bin before a weight is taken. Lengthen only to slow the next cycle start, thereby lowering the pile of material in the mix chamber, and, in some cases, improving mixing.

LCL 00027 LOAD CELL limits, low slope, high slope, frequency, zero.
LCH 00039 DO NOT CHANGE except for different weight load cells.
LCF 00079
LCZ 00583

These parameters relate to the characteristics of the LOAD CELLS on your blender. DO NOT CHANGE THEM.

SCR 00000 Special Customer Request function to be activated.
BCR 00000 For BAR CODE input equipped blenders.

The following parameters are all related to EXTRUSION CONTROL only.

XTP 05050 Extrusion Control - TRIP POINT for a Rate adjustment.

As batch timing errors accumulate, this number determines how large the accumulated error must be to force an adjustment.

XCV 00000 Extrusion Control - Extruder speed Control Voltage.
XRC 00004 Extrusion Control - Extruder speed Rate of Change.

These two parameters control the voltage output to the extruder speed control, and its rate of change.

TCV 00000 Extrusion Control - Takeoff speed control voltage.
TRC 00004 Extrusion Control - Takeoff speed Rate of Change.

These two parameters control the voltage output to the downstream takeoff speed control, and its rate of change.

XAL 00005 Extrusion Control - Single Adjustment Limit, percent.

Single rate adjustments are limited to this percentage change.

XUL 00200 Extrusion Control - Upper Adjustment Limit, volts

Adjustments beyond this voltage change will sound the alarm.

CPL Yield Control - Counts per unit Length.

Matches your down stream takeoff speed encoder to the software.

PTD 00020 Yield Control - Pulse Train Delta

Allows slight errors in encoder pulse train pulse rate

LIQ 00000 For LIQUID COLOR applications using dual pumps.

Allows automatic switching when current container runs out.

MCT 00000 Monitor Cycle Time

Alarms if normal cycle timing exceeds previous cycle time by a specified amount. Used to detect mechanical failures.

FULL EXPLANATION OF PARAMETERS

Most parameters begin with R, N, C, or A. These letters indicate which dispense the parameter controls: REGRIND, NATURAL, COLOR, or ADDITIVE. In the following explanations, only the 2nd and 3rd letters are referenced for each group of codes that start with R, N, C, and A.
=====

FLG (change to enable the RECIPE, BATCH, FAST and TAG keys)

FLG is a SET of flags for turning on the FAST, BATCH, FAST and TAG keys. These four keys will NOT WORK and there associated functions are not available, unless this parameter is set properly.

When all digits are set to 0 (FLG 00000), all four functions are OFF.
The second digit set to 1 (FLG 01000), will turn the TAG key on.
The third digit set to 1 (FLG 00100), will turn the RECIPE key on.
The fourth digit set to 1 (FLG 00010), will turn the FAST key on.
The fifth digit set to 1 (FLG 00001), will turn the BATCH key on.

The TAG key (3rd row, 3rd key) is useful for entering information that you wish to be "tagged" to all printouts and computer retrievals. Work Order and Operator numbers may be entered and displayed. Any computer loaded recipe number may also be displayed.

The RECIPE key is useful for storing thumbwheel switch settings under a single numbered recipe. Up to 99 may be stored. To enable the RECIPE key, place a 1 in the 3rd position of the parameter.

The FAST key allows the unit to operate in a faster, higher output, mode. Output may be doubled in this way. To enable the FAST key, place a 1 in the 4th position of the parameter.

The BATCH key allows you to signal that you have processed a certain amount of material, or for filling a barrel or gaylord to the top without the need for a level sensor to stop the process. To enable the BATCH key, place a 1, 2, 4, or 7 in the 5th (last) position of the parameter.

Set to one (00001), the unit will dispense until the preset batch amount is reached and then will stop and alarm. Set to (00004), the unit act as above but also turn on the ADDITIVE output. Set to (00007), the unit will turn on the Component 7 output. These are then available as additional higher voltage alarm outputs.

Set to two (00002), the unit will alarm but will continue running when the preset amount is reached. (Additional alarm outputs are not available.)

See KEYPAD section, for full explanations of these 4 keys.
=====

_PO (for Micro Pulse devices only)

_PO sets the ON and OFF time of the specified device during the time period that the device is operated. This results in a "pulsed" output. This is used in combination with a "micro pulse" equipped slide gate. Set to 00000 for normal operation. Set to 00101 for

pulsed operation. The first three digits (001xx) controls ON time in tenths of seconds. The last two digits (xxx01) controls OFF time. Larger numbers produce slower dispense rates without any increase in accuracy. Smaller numbers may not allow enough time for the slide to shift fully.

Pulsed Output may also assist in dispensing regrind and some powders when these materials tend to bridge. A parameter of 00501 will produce a 1/2 second open time (5/10 seconds), a long enough time to allow a significant dispense, followed by a 1/10 second close time, just enough to close the gate fully. The rapid gate movement may help in keeping material flowing.

=====

MPO for Micro Blender air driven reciprocating mixer.

MPO sets the timing, in tenths of seconds the clockwise and counterclockwise timing of the mix blade. MPO 00010 is 1 second for each direction.

=====

_AL

_AL Alarm FLAGS. When material runs out, or for some other reason material does not dispense fully, these flags will instruct the controller what to do.

The last digit is number of retries before the action.

The next to last digit is the action:

00000 = NO ALARM, NO RETRIES
00001 to 09 = ALARM, Continue retries.
00011 to 19 = ALARM, Stop retries, Continue process.
00021 to 29 = ALARM, Stop retries, Stop process.
00031 to 39 = NO ALARM, Stop retries, Continue process.

00000 = no alarm, no pause in process, no retries. This is the normal alarm configuration for the Regrind dispense.

00001 to 00009 = sound alarm after specified number of retries and continue retries until successful. The process will not continue until the fault condition is corrected. The last digit determines the number of retries before sounding the alarm. This is appropriate for all important components; natural, color, and additive, and sometimes regrind.

00011 to 00019 = sound alarm after specified number of retries but then stop the retries and continue with the remainder of the cycle. The alarm will continue until the fault condition is corrected or until the next cycle begins. The last digit determines the number of retries before sounding the alarm. This would be appropriate if you wish to make several attempts at a dispense, such as regrind, but you wish the process to continue even without the component.

00021 to 00029 = same as 1 to 9, Stop Process, Sound Alarm, but NO more retries. Just sound alarm and wait. Press the RESET button to clear alarm and start the retries again. Appropriate ONLY if you absolutely want operator intervention to occur when material runs low. In other words you do not want any automatic loading or

other correction to allow the process to continue.

00031 to 00039 = DO NOT sound alarm. After specified number of retries stop the retries and continue with the remainder of the cycle. The last digit determines the number of retries before continuing with the process. This would be appropriate if you wish to make several attempts at a dispense, such as regrind, but you wish the process to continue without any alarm indication.

The first three digits of this parameter (_AL xxx00) may be used to STOP and ALARM the blender if an overdispense occurs by the number of grams specified. For example, CAL 02004 will cause the system to STOP and ALARM if the COLOR dispense is 20 grams over target. (C - OVER) will be displayed. Use PAUSE (or POWER OFF) to reset the Alarm condition. If a printer is connected, a standard cycle printout will occur.

=====

MIX (change to run the mixer a longer timed period)

MIX indicates the TIME that the mixer will run after the weigh bin dump valve opens in seconds. Adequate mixing can be accomplished in a short time. Additional mixing may cause separation and may create a static problem with the material.

The default value is (00010), allowing an initial mix time of 10 seconds. A maximum setting of 29999 will produce a mix time of over 8 hours. Setting the mix time to 99 (MIX 00099) will cause the mixer to run 360 seconds (6 minutes).

=====

JOG Mix blade JOGS, count and interval.

JOG indicates the number of times the blade will jog after initial mixing is ended, plus the time interval between these jogs.

After mix TIME is complete, the mix blade is jogged about 1 turn every 1/2 minute. These jogs serve to level the pile of material in the mix chamber, insuring that the sensor does not remain covered for too long. The first 3 digits (030xx) of the parameter indicate how many jogs will occur. The last two digits (xxx30) indicate the frequency (or interval) in seconds.

The default setting of (03030) produces a jog every 1/2 minute for up to 30 jogs. You may lengthen or shorten these numbers as required. A maximum setting of (29999) (299 jogs, once every 99 seconds) produces a maximum jog time of over 8 hours.

=====

FCV (Delays opening and closing of the flow control valve)

FCV controls three different items:

- 1) Digit 1 can reverse the output logic of the computer.
- 2) Digits 2 and 3 set the time delay before closing.
- 3) Digits 4 and 5 set the time delay before opening.

The most important and primary use of FCV is to set the TIME, in seconds, that the flow control valve delays before opening (4th and 5th

digits (FCV 000xx). If your unit is equipped with a Flow Control Valve, under the mix chamber, it is programmed to open whenever the sensor is covered. It will close again immediately when the sensor is uncovered. This assures that material has time to mix before dropping into a bin below. When a batch is dropped into the mix chamber the sensor is covered. To prevent unmixed material from dropping immediately out the bottom, the mix valve is delayed for a time to allow mixing to occur first. This parameter controls the time that the Mix Chamber Valve remains closed after a batch has been dropped.

The primary function of the valve is to assure mixing. As such it seems best to keep as high a level as possible in the mix chamber. However, if the chamber gets too full (over the blades), mixing is not as good. To allow the chamber to empty to a lower level after the sensor is uncovered, we can also DELAY the CLOSING of the flow control valve. This is done by using the 2nd and 3rd digits (FCV 0xx00) to specify a delay time. (FCV 00206) delays closing by 2 seconds.

If the first digit is set to a 1 (FCV 10006), the signal output to the air solenoid is reversed. Normally, the computer puts out a voltage to open the valve. With this flag set the computer puts out a voltage to close the valve. For this reverse logic to work correctly, you must reverse the air lines to the flow control valve air cylinder.

Normal power-off position for the valve is closed. Some customers prefer the valve open when all power is off. This option allows this reversed "power off" position. With power on, no difference is apparent.

=====

DTI (probably no need to ever change this)

DTI is the maximum TIME allowed for the weighing bin to dump at the end of the cycle. The software will close the bin earlier if it detects no weight change occurring. This time determines the maximum time that is allowed for the bin to empty. We set this maximum time limit according to the model and batch size.

=====

KDF / WDF (change only if you have an extreme vibration problem)

KDF / WDF is the maximum acceptable variation in GRAMS between two consecutive weight readings. One weight reading requires 1 second of time. Two readings are always taken and they must be within WDF grams of each other to be accepted as valid. Readings are taken continuously until two consecutive readings meet the criteria. This prevents a single accidental bump of the scale from causing a grossly inaccurate reading.

WDF is used for starting tare weight, and each component dispense weight. KDF is used for Load Cell calibration weights.

=====

BER

BER is the BAILOUT ERROR weight. Dispenses are controlled by very accurate timing. However, as a precaution, the weigh bin is constantly monitored during each dispense. If bin weight is found to exceed

target weight during the dispense, a BAILOUT occurs. This ends this dispense immediately just like reaching the end of the dispense time. This in no way effects accuracy. The dispense is checked and retries occur if required.

A bailout does not occur unless target weight is exceeded by the weight given in the BAILOUT ERROR parameter. This is primarily to prevent vibration from causing a false bailout to occur during a very small dispense. We set this parameter to a default of 00200 (20 grams or 200 grams). If vibration is causing false bailouts, then you may want to set a higher value in this parameter.

If the BER parameter has a 1 in the last position, (BER 00201), then a printout will occur of all cycle data anytime a bailout occurs for any single component. This is helpful if you want to be aware of occurrences where dispenses significantly exceed target. This will be the same information that you see when the PRINT flag is on (*54). A printer must connected.

=====

_XT (change if you want less then 00.1 percent)

_XT, is a number that will alter the meanings of the thumbwheel switches for COLOR (CXT) or ADDITIVE (AXT). This number, when set, will be divided into the thumbwheel setting, thereby reducing it's value. The only valid entries are 10 and 100. When set to "00010" the decimal point is moved left one place and the setting is read as X.XX percent. When set to "00100" the decimal point is moved left two places and the setting is read as .XXX percent. This allows closer control where requested dispense is less than 1 percent. When set to "00000", this parameter has no effect.

NOTE: MLAN does not display settings as changed, but does all calculations correctly.

=====

ROC (change if you want to add COLOR to your REGRIND)

ROC indicates the PERCENT of REGRIND that will be treated as natural when the COLOR and ADDITIVE dispenses are calculated. If you feel it is necessary to add a little color or additive to your regrind then this parameter will automatically see that this is accomplished.

EXAMPLE: ROC set to (ROC 00020).

The 20 means take 20 % of the REGRIND dispense and ADJUST the NATURAL dispense by this amount. Whatever amount of REGRIND is added, 20 percent of this amount will be added to the Natural amount before a color calculation is made.

Regrind dispense = 600 grams, Natural portion = 1400 grams.

At 4 percent, if ROC=00000, Color would be 56 grams.

If ROC=00020; increase Natural by 20 % of 600, (120 grams).

Color is now calculated to be 4 % of 1520 grams (1400+120), which equals 61 grams.

In some cases, the addition of pre-colored regrind tends to produce overall better coloring because of more uniform dispersion of pigment. In this case you may want to add less color to the Natural portion when Regrind is present. Placing a 1 in the first digit of the

ROC parameter (ROC 10000), will cause a portion of the Regrind to be SUBTRACTED from the Natural portion, instead of added.

EXAMPLE: ROC set to (ROC 10020).

The 20 means take 20 % of the REGRIND dispense and ADJUST the NATURAL dispense by this amount. The 1 means adjust by SUBTRACTION. Whatever amount of REGRIND is added, 20 percent of this amount will be subtracted from the Natural amount before a color calculation is made.

If Regrind dispense = 600 grams, and

Natural portion = 1400 grams,

Color, at 4 percent, would be 56 grams if ROC=00000.

If ROC=10020; reduce Natural by 20 % of 600, (120 grams).

So color is calculated to be 4 % of 1280 grams (1400-120), which equals 51 grams.

=====

ROV

ROV is a parameter that will allow your unit to AUTOMATICALLY change to a higher REGRIND USAGE in the event that the amount of regrind being produced exceeds the usage rate.

NO LEVEL SENSORS are required for this parameter to work.

The first two digits of the parameter number represent a CYCLE COUNT, the last three digits represent a PERCENT. When EITHER number equals zero, the parameter has no effect.

If your system dispenses the full requested amount of regrind for the number of consecutive cycles specified by the CYCLE count, it automatically jumps to the PERCENTAGE indicated by the last 3 digits.

This parameter is useful if your process is one where a runner is molded, ground up, and loaded back into the regrind hopper immediately and continuously every cycle.

For example: Say your runner represents 20 percent of your shot weight. You set your controller to 25 percent regrind. Under normal conditions your system adds back the 20 percent of scrap that is produced each cycle, only occasionally dispensing up to the maximum 25 percent that the setting calls for. Since supply is limited to 20 percent, you never dispense a full 25 percent more than once or twice in a row.

Now say you start producing all bad parts and the entire shot is being feed into the grinder as scrap. Dispenses will now be a full 25 percent every cycle. The regrind hopper will also begin to fill.

With this parameter set to (ROV 10100) (10 cycles and 100 percent), after 10 cycles have occurred at the full 25 percent, the unit will automatically start using regrind at 100 percent

This prevents your hopper from becoming full. This is critical in fully automated systems that are evacuating the chamber of a grinder continuously and rely on space in the regrind hopper to keep the grinder discharge clear.

As soon as one cycle occurs that does not dispense the new full amount,

the system takes this to indicate that the regrind hopper is now empty, and the controls revert back to normal.

=====

RHL (LEVEL SENSORS are required for this parameter to work)
(Use only if you have regrind level sensors fitted)

RHL instructs the controller to change the regrind setting if optional level sensors in the regrind hopper indicate high or low conditions.

If set to all zeros (RHL 00000), then this parameter is ignored.

The ROV parameter can alter the way the RHL parameter is interpreted.

If ROV = 0, (ROV 00000), then RHL numbers indicate NEW settings that are to be run when regrind level is high or low.

If ROV = 1 to 9 (ROV 00001) to (ROV 00009), then RHL indicates upper and lower regrind usage limits only, and regrind usage will be adjusted slowly, to these limits, based on the ROV number.

IF ROV equals zero (ROV 00000):

If RHL is set to any value, the first 3 digits of the parameter indicate a new Regrind setting to use when the material level is ABOVE the HIGH level sensor; (sensor is covered). The last 2 digits indicate a new setting to use if material level is BELOW the LOW sensor; (both High and Low sensors are uncovered).

In other words, RHL allows the selection of a percentage that is HIGHER than normal, and a percentage that is LOWER than normal. NORMAL is what you put on the thumbwheel switch.

Sensors are assumed to be covered when NO signal is returned. If a sensor is unplugged from the controller, it is read as "covered".

If you only have ONE SENSOR, it must be used as a HIGH level sensor. The absence of a sensor is read as a covered sensor; so the absence of the high sensor would signal the system to run at the high setting all the time. This would not be acceptable. The absence of the LOW sensor simply prevents the system from ever thinking it is very low. This is acceptable.

With a high level sensor only, the system switches between the NORMAL thumbwheel setting and the HIGH setting indicated by the first 3 digits of the parameter. The last 2 digits have no effect, since a LOW condition is never detected.

Sensors that we supply are wired correctly for this logic. If a "Bindicator" or similar device is used, with a micro-switch dry contact closure signal, then wire to the normally CLOSED contact so that the signal OPENS when regrind covers the bindicator paddle.

The circuit board "pin outs" for each sensor are positive, ground, and signal. If you are wiring using a dry contact closure, only the positive and signal lines are used. When the contact is open, the signal is pulled to ground internally through a resistor.

Example: RHL is set to 90 and 10 percent (RHL 09010).
ROV is set to zero, (ROV 00000).
The "Regrind" thumbwheel switch is set to 25 percent (025).

The Software logic is as follows:

If material level is high, above the high sensor,
the HIGH sensor is COVERED, (returns NO signal);
Regrind runs at the HIGH setting; 90 percent.

If material level is in the middle, between sensors,
the High sensor is NOT covered, (returns a signal),
the LOW sensor IS covered, (returns NO signal),
Regrind runs at the THUMBWHEEL SETTING; 25 percent.

If material level is low, below the low sensor,
BOTH sensors are NOT covered, (both return a signal),
Regrind runs at the LOW setting; 10 percent.

IF ROV equals 1 to 9 (ROV 00001 to ROV 00009):

All the same rules given above apply, except that the thumbwheel switch regrind setting does not jump in one step to a new setting, but, instead, moves slowly to the new setting which acts as a limit. The usage adjustment is made each cycle by the amount specified by the ROV parameter.

Example: RHL is set to 10 and 90 percent (RHL 09010).
ROV is set to 3 (ROV 00003).
The "Regrind" thumbwheel switch is set to 25 percent (025).

The Software logic is as follows:

If material level rises, goes above the high sensor,
the HIGH sensor is COVERED,
Regrind usage will increase 3 percent each cycle up to a high limit of 90 percent.

If material level is in the middle, between sensors,
the HIGH sensor is NOT covered,
the LOW sensor IS covered,
Regrind usage will change 3 percent each cycle, moving back toward the THUMBWHEEL SETTING of 25 percent.

If material level drops below the low sensor,
BOTH sensors are NOT covered,
Regrind usage will decrease 3 percent each cycle down to a low limit of 10 percent.

=====

FUL (change for extremely light or heavy material)

FUL is the full batch weight in GRAMS set at the factory to 2000 grams. The criteria for this number is to not exceed the volume capacity of the weigh bin and to not exceed the load cell capacity. Each load cell is rated for 3000 grams. Total load capacity is 6000 grams. The weigh bin, when empty, weighs about 1200 grams, leaving a net capacity of 4800 grams for weighing material. However, a dispense

over 3000 grams probably would exceed the volume capacity of the bin and, therefore, not be accurate. We have set the full batch weight to 2000 grams which we considered a conservative full batch weight. Higher batch weights will increase maximum throughput rates.

If your Regrind is very fluffy and you use a lot of it, you may find 2000 grams to be too much volume for the bin. Select a lower total batch weight such as 1500 to ensure that the bin never overflows or fills completely to the dump valve.

=====

MAX (set automatically if FUL parameter is changed)

MAX is the maximum gram weight which the software will allow as a target for dispensing. The initial Full weight target is set by the FUL parameter. As dispenses progress, an over dispense of one component may cause a new target to be calculated for future dispenses in order to maintain proper requested ratios. A recalculated target is not allowed to exceed the value held in the MAX parameter. If you change the FUL parameter, the MAX parameter will automatically be set to a value 50 percent higher then the FUL setting.

=====

TH and TL

TH and TL are acceptable error limits for TARE WEIGHT.

Before a dispense cycle begins, the software checks to see that the weigh bin is in place and not already full of material. To do this it looks at the starting TARE weight.

If Tare weight is below the value of TL, (50 grams), the software assumes the bin is either missing or hung up on something. In this case the ALARM sounds.

If Tare weight is above the value of TH (100 grams), the software assumes material is in the bin. In this case the ALARM sounds and the weight bin dump flap operates in an attempt to empty the weigh bin.

If you are processing a material that has a tendency to hang up in the corners of the bin, you may wish to widen the range of acceptable starting tare weight. Since tare weight is always subtracted from dispense weights, these errors do not effect accuracy.

=====

PRT (change to get AUTOMATIC printing of material totals)

PRT, when set to any number other than zero, will cause the processor to output all current material usage totals, at regular time intervals, to the printer port. The number you enter will dictate the time interval in minutes. All timing starts from MIDNIGHT. for example, an entry of 00120 will cause totals to print at 2 AM, 4 AM, 6 AM, etc. Printing always waits until a cycle has just ended. A setting of 10000 is a special case. This will cause a printout after every cycle. A printer must be connected. If one is not, the routine will abort and blending will continue.

_SE (This might be useful)

_SE is the upper SETTING limits for the thumbwheel switches. This allows a reasonable cap to be set for each component so that an operator cannot accidentally set the controls to an excessively high setting. For color and additive, these limits will ensure that expensive material is not wasted. Thumbwheel settings that are greater than the limit are held to the limit.

EXAMPLE: If the highest color usage in your plant is 6%, you may enter this upper limit in the parameter table. Since settings are stored as 1/10s of percent (##.#), the parameter would be:
CSE 00060

Color thumbwheel settings above 060 will be held to 6 percent.

NOTE: If you wish to positively fix the settings so that the thumbwheel switches have no control and no one can change them without authorization, you may do this by using the KEYPAD to enter any or all settings. To do so:

```
+-----+
| Press: *          Display will say: (PASSWORD) |
| Press: 22222      Display will say: (P      x) |
| Press: SET        Display will say: (SETTING ) |
| Press: COL (or ADD or REG)
|                  Display will say: (C = xx.x) |
| Enter: New setting
|
| Press: EXIT       Display will say: (P xxxxx) |
+-----+
```

An LED will light indicating this override condition. This occurs only when the thumbwheel does not match the internal setting.

To later return to thumbwheel control, use the same procedure as above except instead of entering a setting, press the "CE" key when you see the setting displayed.

The operator may still prevent running this component by entering a setting of all ZEROS (00.0). This will override any setting entered by the keypad. If you do not want this override option, enter a 1 as the first digit in the SE parameter. (_SE 1xxxx)

=====
RLO (probably no need to ever change this)

RLO is the lower limit for SETTING the regrind thumbwheel switches. Settings lower than this number will be held to the low limit. Air operated dump valves are not intended to dispense very small quantities. We have set RLO at the factory to 5 percent (00050) allowing a minimum dispense of 5% or about 100 grams.

=====
DLY (consider changing if mixing is a problem)

DLY is the TIME the mix chamber level sensor must be uncovered before a cycle begins. The sensor must be uncovered without

interruption for the full specified DELAY time. To prevent false starts from the mix blade, a 1 second minimum (00244) is recommended.

Sometimes throughput is slow enough that each new batch buries the mix blade for a while. When this happens the material on top does not mix well. To reduce this, you can delay the start of a new batch by adding to the DLY parameter. The new batch is delayed and the level in the mix chamber has time to fall before the next batch is added.

=====

LT1 and LT2 (set ONLY if your controller is modified to control a loader)

The LT1 and LT2 parameters are normally set to all zeros, indicating that this feature is not present on your system.

If you have additional outputs on your GB/WSB controller for driving a loading system, then this parameter should be set to some number indicating how many seconds you will attempt to load before sounding the ALARM. A sensor input to the controller tells the loader to load. When the sensor is covered the loader stops. If the sensor is not covered within the specified number of seconds, the strobe light and the beeper are activated and the display flashes (LOADER 1) or (LOADER 2), depending on which one has the problem.

The LT1 and LT2 parameters specify this delay time before alarm.

All circuit boards have provision for connecting level sensor inputs for 2 loaders. When this loader option is being used, uncovering level sensor 1 will cause pin G (7) of the eight pin Amphonal plug to be energized. This can be used, through a relay, to drive a loader.

=====

_PT (for augers and micro pulse devices only)

The _PT parameters will cause the first try dispense to be a percentage of the full target weight. For example, with color set to (CPT 00090), the first try will be 90 percent of the full target amount. Retries then occur, but each will target only 50 percent of the remaining requirement. A series of progressively shorter retries should be expected, until the retry parameters are satisfied (RP and RD). The _PT parameter is most effective for slow dispense devices, like augers. When setting _PT, also set the _RP parameter to 00001. This forces retries up to within 1 percent of target, instead of 10, improving accuracy.

=====

_WT and _TI (adjusted automatically after each cycle)

The _WT, and _TI parameters are related to the flow rate or dispense rate of each material. These can be changed manually or set AUTOMATICALLY by using the RATE CALIBRATION routine described in the KEYPAD section of the manual. These numbers are automatically corrected as necessary after each cycle.

_WT and _TI are WEIGHT and TIME numbers that, taken together, represent the actual flow rate for the specified material (WT/TI).

This rate is used to calculate an exact time period to dump the required quantity of material.

Both of these numbers are adjusted by the computer logic after each cycle as a means of continuously calibrating the dispense times.

This rate correction takes place continuously and the battery-backed RAM maintains the correct rate even when power is turned off.

If, for some reason, you were to set these numbers manually, (for example, if the load cells are damaged and you want to adjust the VOLUMETRIC flow rate), an example of a proper setting would be as follows: For a 1" auger feeder with a 60 RPM motor; this unit dispenses 8 grams per revolution which is 8 grams per second. Since the _WT gram number indicates tenths of grams (model 2xx) and the _TI number indicates interrupts (at 244 per second) then the proper numbers would be:

_WT 00080 and _TI 00244.

The computer automatically bumps both numbers up in value by doubling them both until at least one number exceeds 16,000. The ratio (rate) is still the same but error correction routines work better with higher numbers.

=====

_MI (set AUTOMATICALLY each time power is turned on.)

_MI numbers are set to one half the amount of material, in grams, that can feed in one second based on normal valid dispense rates. A valid rate is considered the normal dispense rate that occurs under normal conditions with equipment functioning properly. When a rate lower than half this actually occurs, it is assumed that an equipment malfunction or loss of material has occurred. Under these circumstances, normal rate correction routines are bypassed.

EXAMPLE: For a 1" auger feeder with a 60 RPM motor drive, the normal metering rate is about 8 grams per revolution or 8 grams per second. Since the _MI number is expressed as tenths of grams, (model 2xx), half of this is expressed as (_MI 00040).

It is safe to use a _MI number that is too low but NOT safe to use a number too high. Error correction routines will not work when this number is too high.

This number is reset to 00001 every time power is turned on. After the system detects 10 good dispenses, (no retries, no bailouts), then the MI parameter is AUTOMATICALLY set to 50 percent of current flow rate. The RATE CALIBRATION routine will also set this parameter. Periodically, during production, if dispenses have occurred in a very uniform manner for an extended period of time, the MI parameter is reset based on these dispenses.

=====

_NC (changes itself AUTOMATICALLY over time)

_NC is the allowable GRAM error within which NO flow rate corrections are made by the software. Gram weight errors that are equal to, or less than, this number will be accepted and no error

corrections will take place. Since no equipment is perfect, we must accept that a certain range of error is normal. To make corrections within this range only adds an additional error due to hunting, and broadens the error range. This parameter controls and prevents this. This parameter is adjusted automatically by the software according to the actual conditions of the metering.

This number has been set based on our experience with the dispense devices. If, over time, the computer finds that the number is too large or too small, it will automatically adjust it to match the actual conditions that exist with your equipment. These adjustments occur in small increments once every 20 cycles. A change is made only if needed. Checking this number from time to time will indicate the normal error range that is occurring with each dispense device.

If you manually set this number to a very high value, you will effectively eliminate all error correction attempts for the component. Gradually, over several months, the software will adjust this number back down. If you wish to defeat a component's error correction routines permanently, you may set NC to (_NC 29999). The software recognizes this number as special and will not change it. This high setting eliminates error correction attempts for this component. The component is still weighed, and retries still occur if short, but the timing of each dispense is based only on previously learned rates and never adjusted from new experience. A very small dispense in a high vibration environment may actually be more consistently accurate if no adjusting occurs.

=====

_RP and _RD (probably no need to ever change this)
(_RD is reset AUTOMATICALLY shortly after POWER ON)

These two parameters determine the dispense shortage error that is be acceptable for each component.

_RP is the shortage expressed as a PERCENT of the target dispense weight and _RD is the shortage expressed in GRAMS. These parameters are used together, either one will force a "retry".

A "retry" is an additional dispense that is calculated to add the amount of material that is short. This comes into play only when the amount dispensed is less than expected.

Retries will occur until the difference between the required amount and the metered amount is equal to, or less than, the _RP percent difference AND the _RD weight difference.

These numbers dictate just how close to perfect the dispense has to be before going on. If the dispense overshoots the target, then the process continues. These parameters only control the degree of weight SHORTAGE that is acceptable.

The _RP parameter is important when SMALL DISPENSE requests for color or additive are made. Large PERCENT errors are more likely to occur when very small dispenses are requested.

The _RD parameter is important when LARGE DISPENSE requests for color or additive are made. Large GRAM weight errors are more likely

to occur when very large dispense percentages are being requested.

Depending on the accuracy of the metering device, a certain amount of hunting is to be expected from one dispense to the next. Allowing the software to stop trying when it gets sufficiently close to the target results in more perfect average dispenses. The mix chamber and the barrel of your process machine average out the small errors that occur from cycle to cycle.

If no shortage is ever to be allowed, setting `_RP` to 00000 will prevent any shortage from occurring. This will, however, cause an overall average error on the plus side.

NOTE: Remember that EITHER ONE of the these two parameters will cause retries to occur. BOTH parameter conditions must be met before the process will continue, with one exception: If the ALARM parameter (`_AL`) is set to 00000, indicated that you do not want any retries to occur, then these two RE TRY parameters will have no effect. The first dispense will always be accepted and no retries will be made.

The `_RD` parameter is adjusted automatically by the software after every power on, after the blender has been operating smoothly, without retries, for 10 cycles. If you wish to change `_RD` and have it stay changed, then enter a 1 as the first digit in the parameter: (`_RD 10020`). The 1 signals the software to NOT make any automatic adjustments to this parameter.

=====

`_LA` (change if you change metering device)

`_LA` is the lag TIME before dumping actually starts. This lag time is the time it takes for the dispense system to mechanically respond to the controller's signal to start. Lag time is automatically added to all dispense times.

Changing the means by which a device is operated such as using a different diameter air cylinder, or a different drive system for an auger feeder may require a change in this parameter.

These parameters represent the number of interrupts (time) that pass before the feeder or dispense system actually begins to dispense. There are 244 interrupts per second. To determine these times, use the TIME dispense function in the Manual mode (KEYPAD instructions).

Following the instructions given in the KEYPAD portion of the manual (TIME key), start with a dispense time of 1 (001). Try successively higher time numbers until some movement is noted in the mechanical device and a minimum amount of material IS dispensed on each try. This is the MINIMUM lag time number; the lowest number that DOES cause some movement and DOES result in a minimum dispense. Add 5 to this time period and use this number as the lag time. Lag times that are too short can cause problems. That is why the MINIMUM lag time determined above should be increased by 5 as a safety factor. Use minimum plus 5.

These numbers are preset at the factory for the equipment we have supplied. When a dispense of only a few grams or a fraction of a gram

is required, the _LA number is very important. A lag time number that is too small will result in no dispense at all because of inadequate time for the device to operate. A lag time number that is too big may result in over dispenses when very small amounts are called for. Since too small a number may stall the process, always add 2 to the minimum as a safety. As a further safety, the software automatically doubles the lag time number if a dispense occurs without any weight being detected.

Typical LAG TIMES are: (minimum plus five)
12 - for an AC motor being powered through a relay.
20 - for a 1" air cylinder sliding a dispense valve.
127 - for an automatic speed controller.

=====
PRC (not necessary to ever change this)

PRC is the maximum allowable PERCENT rate change per cycle. If a large dispense error occurs, flow rate corrections do not exceed this percent number. This prevents large swings in timing of dispenses and provides for stable dispense rates under difficult conditions. For example, when dispense quantities are very small (one or two grams), overfeeding by several grams is a distinct possibility. This type of error represents a very large percentage error to the controller. However, a large correction would not be appropriate but, instead, would cause a "hunting" of dispense time that would result in further large errors. This parameter prevents this.

=====
STL (probably no need to ever change this)

STL is the TIME period allowed to pass after a dispense has occurred, but before a weight reading is taken. This settle time allows falling pellets to reach the bin and also prevents their impact with the bin from adding to the weight reading.

=====
LCL, LCH, LCF and LCZ

These four parameters are set to match the characteristics of the type of load cells used in your system. DO NOT ALTER THEM. LCL and LCH are the acceptable LOW and HIGH limits of load cell output expressed as pulses per gram of weight. LCF is the lowest acceptable FULL scale load cell output in raw signal pulses per second. LCZ is the highest acceptable ZERO scale output. The LCF and LCZ numbers stored here are multiplied by 256 before being used by the software.

=====
SCR Special Customer Request

If a customer has a special software requirement that has no benefit to anyone else, then this request is hidden in the software and activated by the appropriate code number being entered into this parameter. Believe me when I say that these request are useless to anyone else.

=====
BCR Use only for blenders with BAR CODE reader input.

If you know ONE bar code input is required to before a new cycle is initiated, set this parameter to 00001. The blender is then prevented from operating until one single valid input is received. If two inputs are expected, set this parameter to 00002, etc.

=====

XCV + XRC For Extrusion Control Systems only.

XCV, "Extruder speed Control Voltage" is used in conjunction with our extrusion control software. This number can range from 0 to 1000 (XCV 00000) to XCV 01000), and determines the voltage outputed on pin S of the Amphonol connector. Pin R is the neutral or zero reference for this voltage output.

The voltage ranges from 0 to 10 volts. 01000 = 10.00 volts. This parameter can be set manually, however it is intended to be controlled by MLAN communications in conjunction with our extrusion control software.

Whenever the software is instructed by MLAN to ramp this voltage up or down, the controller display will say (RAMPING) during the time the voltage is being adjusted.

XRC, "Extruder speed Rate of Change", determines the ramp up or ramp down rate of the XCV parameter, above. It can range from 0 to 10 (XRC 00000) to (XRC 00010). Default setting is 00004.

When XCV changes, it does so gradually, making small incremental changes every 10 interrupts, or about 24 incremental changes per second. The XRC parameter determines the maximum value of each incremental change. For example, if XRC is set to 1 then the XCV number will increment by 1 count (0.01 volt) every 10 interrupts, for a rate change of 24 counts (0.24 volt) per second, which is full range of 1 to 10 volts over about 41 seconds.

=====

TCV + TRC For Extrusion Control Systems only.

These parameters control a second 0 to 10 volt voltage output on for controlling downstream equipment Takeoff speed. They operate the same as the XCV and XRC covered above except they move in the opposite direction, higher to reduce weight per foot, lower to increase weight per foot.

=====

XTP For Extrusion Control Systems only.

The LAST TWO digits of the XTP parameter specify the TRIP POINT when software will make an adjustment to the throughput rate number, which will then cause a change in extruder speed. Speed is held steady until there is significant indication that the throughput rate is incorrect. The software analyzes each batch watching for any meaningful deviation from current controlling rate. These last two digits of this parameter specify the accumulated error, indicated as a percent of full batch weight, required to trip a change. For example, when set to 30 on a 200 series blender, this would indicate a 600 gram total error must accumulate before adjustment, 30 percent of the full

batch weight of 2000 grams.

The FIRST TWO digits indicate how many cycles must run without a rate adjustment before the operator is permitted to switch from voltage (manual) control to Throughput (automatic) control. This is a factor during startup only. Larger numbers assure a very accurate rate has been learned. This is preferred if you like the way your extruder is running and do not want any further adjustment unless a real problem is detected. On the other hand, if you know that you want output to be a predetermined value, like 1000 pounds per hour, then switching sooner is better. In this way the operator can enter the rate he desires sooner, and the blender can immediately make any required adjustments required to target in on this rate. Too large a number causes delayed response, too small causes hunting. Larger is safer since you do not want "false" adjustments to occur.

This parameter starts at XTP 50030, 30 percent of full batch weight accumulated error and 5 cycles required without adjustment before your operator can switch to the Throughput mode. A "T" is displayed when the 5 cycle requirement is reached.

=====

XAL Extrusion Control Adjustment Limit

XAL limits the degree of change that the software can make in one adjustment cycle. Default setting is 00005, 5 percent. Operator entered rate changes are not limited.

=====

XUL Extrusion Control - Upper Adjustment Limit

XUL sets an upper limit to how far the software can adjust the extruder speed (control voltage). If this limit is exceeded, then the adjustment is NOT made, and the ALARM is turned on. Pressing the V/T key switches the control to Voltage Mode. When pressed again, the unit returns to Throughput Mode, and a new Limit is set. Further adjustments may now occur to the new limit.

Default is 00200, 2 volts. The idea is that once control is established, adjustments upward of more than 2 volts indicate conditions that should be attended to, a clogged screen pack for example. You may wish to reduce this number so that operators are warned well in advance of such conditions.

=====

CPL Yield Control - extrusion control.

Customers using Yield Control require a pulse generator, or shaft encoder, mounted on downstream takeoff equipment to signal the line speed to the blender. In operation the software displays GRAMS per unit length, which may be per foot, per yard, per meter, or whatever. For whichever unit length you select, enter the pulses per unit length in this parameter. In America, a typical shaft encoder delivers 600 or 1200 pulses per foot. Set the parameter to 600 or 1200. Everywhere else you are most likely concerned with meters. The proper setting for this parameter is the number of pulses per METER that the encoder generates.

=====

PTD Yield Control - extrusion control - Pulse Train Delta

This allows some error in the pulse train rate. For example, if the pulses are being generated at a rate of 6030 per minute, which is 100.5 per second, and we count pulses every second, then we will count 100 for one second, 101 for the next, then 100, then 101 and so on. This "error" could cause adjustments to occur when no adjustment is warranted. The PTD parameter specifies how many over or under pulses have to accumulate before adjustment occurs. In the above example, if 6030 per minute was what we wanted, but counts came in at 101 per second, then an error of 30 would accumulate in 1 minute. The PTD parameter set to 00030 would cause a correction to occur at this level of error.

=====

LIQ For LIQUID COLOR applications using dual pumps color drums.

Liquid Color users generally want the current container of color to run completely out before switching to a new container. Switching early requires the transfer of the unused portion to the next container. This feature allows a standby container to be in place and ready, and instructs the blender to switch to the backup container as soon as the first container runs out, as detected by the lack of weight after a dispense. The default setting is LIQ 00007, which directs the switch to occur to output 7, an output not usually used in FOUR software controllers. Output 7 must first be prewired to an auxiliary output which must be added to the side of the controller. Often, two additional solenoids are added to provide air outputs to liquid pumps that require air for operation.

When conventional pumps are used, two pumps must be present, each connected to a drum of color. Both would have to be plugged into the two outlets on the duplex receptacle on the front of the controller. The parameter would be set to LIQ 00003, which is to say that the "additive" outlet (output 3) is designated as the back up output for COLOR (which is output 4). This means that the ADDITIVE thumbwheels can not be used as this outlet is now being used as the backup output for COLOR.

Other arrangements are possible, but will require some wiring.

=====

MCT Monitor Cycle Time

This parameter acts as the ultimate fail safe precaution. When used, it monitors sequential cycle times, and alarms if a cycle time exceeds the previous cycle time by an amount that is not consistent with proper operation. This provides a means to detect mechanical failures such as a sticking valve or weigh bin gate.

When set to 00000, this parameter is not active.

When set to MCT 02060, an alarm will occur when either a cycle time is double (02xxx) the previous time, or exceeds it by 60 (xx060) seconds.

At power-on this alarm is always set off and disabled. Once smooth running is established, the alarm is enabled. Smooth operation is established using the same logic that Extrusion Control uses.

If the alarm is activated, the display will say (TIME OUT).

Press the alarm silence button to reset the alarm. A new cycle will also reset the alarm.

If another alarm is currently active (material not dispensing for example) then this Monitor alarm is ignored or reset.

=====

PARAMETER DEFAULT SETTINGS - FOUR SOFTWARE

Here is a complete list of the "default" entries for all parameters as they are provided in the original program, and as they will appear after a CLEAR ALL or a model change.

The Model 220 list is the ORIGINAL BASE list.
 Models 240, 140, MB, and 940 show only changes from the 220 list.
 Models 1840, 420, and 440 show only further changes from the 940 list.
 Models 131, 122 show only changes from the 140 list.

| Base 3K | | | | | | Base 10K | | | | |
|---------|-------|-----|-------|-------|-------|----------|-------|-------|------|------|
| Model: | 220 | 240 | 140 | 131 | 122 | MB | 940 | 1840 | 420 | 440 |
| FLG | 00 | | | | | | | | | |
| RPO | 00 | | | | | | | | | |
| NPO | 00 | | | | | | | | | |
| CPO | 00 | | | 00101 | 00101 | | | | | |
| APO | 00 | | | | 00101 | | | | | |
| MPO | 10 | | | | | | | | | |
| RAL | 00 | | | | | | | | | |
| NAL | 04 | | | | | | | | | |
| CAL | 04 | | | | | | | | | |
| AAL | 04 | | | | | | | | | |
| MIX | 15 | | | | | | 30 | 99 | 15 | 15 |
| JOG | 3030 | | | | | | | | | |
| FCV | 05 | | | | | | | | | |
| DTI | 06 | | 04 | | | | 06 | 08 | 10 | 10 |
| KDF | 10 | | | | | | 02 | 04 | 02 | 02 |
| WDF | 10 | | | | | | 02 | 04 | 02 | 02 |
| BER | 1000 | | | | | | 200 | | | |
| CXT | 00 | | | | | | | | | |
| AXT | 00 | | | | | | | | | |
| ROC | 00 | | | | | | | | | |
| ROV | 00 | | | | | | | | | |
| RHL | 00 | | | | | | | | | |
| FUL | 20000 | | 10000 | | | 4000 | 9000 | 18000 | 4000 | 4000 |
| MAX | 30000 | | 15000 | | | 6000 | 13500 | 27000 | 6000 | 6000 |
| TH | 1000 | | | | | | 1000 | 1000 | 200 | 200 |
| TL | 500 | | | | | | 500 | 500 | 100 | 100 |
| PRT | 00 | | | | | | | | | |
| RSE | 11000 | | | | | | | | | |
| CSE | 11000 | | | | | | | | | |
| ASE | 11000 | | | | | | | | | |
| RLO | 50 | | | | | | | | | |
| DLY | 244 | | | | | | | | | |
| LT1 | 00 | | | | | | | | | |
| LT2 | 00 | | | | | | | | | |
| RPT | 00 | | | | | | | | | |

| | | | | | | | | | |
|-----|-------|-------|-------|-------|-------|-------|-------|-----|--|
| NPT | 00 | | | | | | | | |
| CPT | 00 | | | | | | | | |
| APT | 00 | | | | | | | | |
| RWT | 26000 | 26000 | 18000 | 22400 | 30000 | 20800 | 20800 | | |
| RTI | 976 | 976 | 976 | 15616 | 976 | 7808 | 7808 | | |
| NWT | 26000 | 26000 | 18000 | 22400 | 30000 | 20800 | 20800 | | |
| NTI | 976 | 976 | 976 | 15616 | 976 | 7808 | 7808 | | |
| CWT | 20480 | 26000 | 1280 | 22400 | 20800 | 2048 | 20800 | | |
| CTI | 31232 | 976 | 31232 | 15616 | 7808 | 31232 | 7808 | | |
| AWT | 20480 | 26000 | 1280 | 22400 | 20800 | 2048 | 20800 | | |
| ATI | 31232 | 976 | 31232 | 15616 | 7808 | 31232 | 7808 | | |
| RMI | 01 | | | | | | | | |
| NMI | 01 | | | | | | | | |
| CMI | 01 | | | | | | | | |
| AMI | 01 | | | | | | | | |
| RNC | 10 | | | | 01 | | | | |
| NNC | 10 | | | | 01 | | | | |
| CNC | 10 | | | | 01 | | | | |
| ANC | 10 | | | | 01 | | | | |
| RRP | 10 | | | | | | | | |
| NRP | 10 | | | | | | | | |
| CRP | 10 | | | | | | | | |
| ARP | 10 | | | | | | | | |
| RRD | 500 | | | | 300 | 100 | 100 | | |
| NRD | 500 | | | | 300 | 100 | 100 | | |
| CRD | 50 | | | | 100 | 05 | 100 | | |
| ARD | 50 | | | | 100 | 05 | 100 | | |
| RLA | 20 | | | 04 | | | | | |
| NLA | 20 | | | 04 | | | | | |
| CLA | 15 | 20 | 20 | 04 | 20 | 20 | 15 | | |
| ALA | 15 | 20 | 20 | 04 | 20 | 20 | 15 | | |
| PRC | 10 | | | | | | | | |
| STL | 122 | | | | | | | | |
| LCL | 27 | | | | 80 | 40 | 80 | 80 | |
| LCH | 39 | | | | 120 | 60 | 120 | 120 | |
| LCF | 79 | | | | | | | | |
| LCZ | 583 | | | | | | | | |
| SCR | 00 | | | | | | | | |
| BCR | 00 | | | | | | | | |
| XCV | 00 | | | | | | | | |
| XRC | 00 | | | | | | | | |
| TCV | 00 | | | | | | | | |
| TCR | 00 | | | | | | | | |
| XTP | 20020 | | | | | | | | |
| XAL | 05 | | | | | | | | |
| XUL | 200 | | | | | | | | |
| CPL | 00000 | | | | | | | | |
| PTD | 00020 | | | | | | | | |
| LIQ | 00007 | | | | | | | | |
| MCT | 00000 | | | | | | | | |
| END | 00000 | | | | | | | | |

CHANGING PARAMETERS

To change a PARAMETER, the sequence of keystrokes is as follows:

```
+-----+
| Press: *           Display will say: (PASSWORD) |
| Press: 22222       Display will say: (P   x.x)  |
| Press: PARA        Display will say: (RRxxxxxx) |
| Press: PARA        Press again to walk FORWARD through list. |
| Press: *           to BACK UP in the list.     |
|                                     |
|           When the PARAMETER you want is displayed, |
|           enter a new setting using the number keys. |
|           You must enter 5 digits. Use leading zeros. |
|                                     |
| Press: EXIT        Display will say: (P   x.x)  |
+-----+
```

Additional information can be found in the KEYPAD section.

SAVING PARAMETERS in the EEPROM

If the changes you have made are PERMANENT, SAVE them in the EEPROM.

Sometimes during normal operation, electrical noise or RF (Radio Frequency) noise will corrupt the processor memory. It may be necessary to do a CLEAR to fix this problem.

A "CLEAR" will clear all data from memory and replace it with information stored in the EEPROM.

So it is a good idea to have an exact copy of RAM stored in the EEPROM for just such an emergency.

To copy ALL PARAMETERS into the EEPROM, the sequence of keystrokes is as follows:

```
+-----+
| Be in PROGRAM mode, first 2 steps above:         |
|                                     Display will say: (P   x.x) |
|                                     |
| Press: *           Display will say: (INSTR --) |
| Press: 23          Display will say: (SAVING  ) |
| Wait:  when done, Display will say: (P   x.x) |
| Press: EXIT        Display will say: (   x.x) |
+-----+
```

With this done, all correct Parameters may be restored from EEPROM to RAM at any time by doing a CLEAR.

To do a CLEAR, hold the "CE" key down when turning POWER ON.

Notice that REG shows a full percentage only, no tenths. The software only accepts full percentage entries for regrind. Tenths are ignored.

TWELVE software will print up to 3 line groups, 4 components per line, printing only those that are currently turned on.

The CYCLE heading:

```
-----  
* 11/10/97 * * 16:17:53 * RECIPE 0000 **ID# 051** **WO 000000* OPR000
```

DATE and TIME this blend cycle was completed. RECIPE, ID, Work Order, and Operator numbers have no bearing on blender operation but aid in identifying this particular blender, and what job was running.

DATA line 1:

```
-----  
FINAL: DISP,%      0.0   .0  1908.3      77.6   4.06  0.0      .00  2000.1
```

For each material, each column shows the final dispensed weight of that material and its percentage of the blend.

In this example Natural dispensed 1908.3 grams. Percentage for natural is not given since it is not set by the operator and is not pertinent. Color dispense is 77.6 grams, 4.06 percent of the natural dispense, slightly over the 4 percent requested.

The final number, 2000.1 is the total weight of the blend. It equals the sum of the component dispenses.

DATA line 2:

```
-----  
RATE: GR/TIME  18224   976   19993   488  12973 31232   10240 31232     9.9
```

These numbers show the RATE of dispense for each material. These are the numbers that the software used to calculate how long to open the slide gate or run an auger, in order to dispense the required amount. This is GRAMS per Interrupts; 1822.4 grams dispensed in 976 interrupts, which is 4 seconds.

The final number, 9.9 grams, is the TEAR WEIGHT of the weigh bin displayed just before the cycle began.

DATA line 3:

```
-----  
1ST DISP,TIME      0.0   00   1908.3   469   77.6  1826      0.0   00     22
```

This shows the first dispense in grams for each material and the timing of that dispense (in interrupts).

If the first dispense weight, (data line 3), matches the final dispense, (data line 1), then no "retries" occurred. In other words, the first try was accepted by the software. If they do not match, then the first try was short and one or more retries occurred. The second number is the dispense time that the software calculated to be a correct first try for the dispense.

The last number (22) is the CYCLE count, a convenient way to keep pages of data in order, like page numbers.

Optional "BAILOUT" line:

232

A 4th data line (not shown in the beginning example) will print if any single dispense goes past its target weight by a certain value, this value set by the BER parameter, normally 200 grams. The example line shown here would indicate COLOR overshoot the target weight after dispensing for only 232 interrupts.

Bailouts are designed to prevent overflows of material when initial software settings, at start up, are entirely inappropriate for the metering device. A larger than normal error correction will occur after a bailout.

Bailouts errors at any time other than startup, usually indicate either very poor flowing material, or excessive vibration. When a bailout occurs the dispense stops immediately for a weight reading. Using this information, the cycle then continues normally.

WHAT TO CHECK FOR.

TOTAL BATCH WEIGHT: (DATA line 1)

Check the TOTAL batch weight, (DATA line 3), to confirm the blender model. 2000 grams indicates 200 series model. 400, 1000, and 2000 gram totals indicate models that use 3 K load cells, which means output information is in 1/10's of grams. 4000, 9000, and 18000 gram totals indicate larger blenders that report information in full grams. Since some numbers in the printout do not include the decimal point, you will want to know if you are reading full grams or tenths of grams.

TARE WEIGHT. (DATA line 2)

In DATA line 2, tare weights should be consistently within a few grams of each other from cycle to cycle. Large variations in the tare weight numbers may indicate excessive vibration, some mechanical interference with the weigh bin, or a faulty circuit board. Tare weights above or below zero are not a problem as long as they are consistently similar from cycle to cycle. When problems are present, tare numbers may vary by up to 50 grams. Variations of 2 or 3 grams are not a problem.

RETRIES: (DATA line 3 and 1, FIRST and FINAL dispense)

When FIRST time dispense, (DATA line 3), does not equal FINAL dispense, (DATA line 1), one or more retries have occurred. Retries are evidence of a problem that will also cause percentage errors.

Retries may indicate possible problems; perhaps the hopper ran out of material, or the flow rate is so erratic that the first dispense was short for no good reason. Parameters `_RT` and `_RP` determine what shortage error is necessary to force a retry.

FLOW RATE NUMBERS: (DATA line 2)

Check the RATE numbers, (DATA line 2), to determine each dispense device.

In the example above:

In the REGRIND column, 18224 and 976 translate to 1822.4 grams in 4 seconds (244 interrupts = 1 sec), or 455.6 grams per second, typical for a regrind flowing through 3" round or 2"x3" dispense valves.

In the NATURAL column, 19993 and 488 indicate 1999.3 grams in 2 seconds, or 999.6 grams per second flow rate. This is a heavy natural material, not polyethylene. Perhaps Lexan or a glass filled material.

In the COLOR column, 12973 and 31232 indicate 1297.3 grams per 31232 interrupts, or 128 seconds, for a flow rate of 9.99 grams per second. This is a 1 inch auger feeder, from which we would typically expect about 8 grams per second. More recent auger feeders use faster motors delivering about 16 grams per second.

In the ADDITIVE column, 10240 and 31232 indicate a flow rate of 8 grams per second EXACTLY. Since it is exact, and since these two numbers are, in fact, the "default" settings from when the blender was first installed, we know that "Additive" has never been run on this blender, or at least not since the last "CLEAR ALL" was performed.

DATA line 3 dispense weight of 0.0 for additive, and the TOP-OF-PAGE heading showing Additive set to 00.0 percent also confirm that Additive is not being run.

The following information will help you determine what devices are in place on a blender.

| Device: | Approximate grams per second: |
|---|-------------------------------|
| 1/2 inch augers, micro pulse valves | 1/2 to 2 |
| 1 inch augers, 60 RPM motors | 6 to 10 |
| 1 inch augers, 120 RPM motors | 12 to 20 |
| 100 series valves dispense | 250 to 450 |
| 3" round and 2x3 inch valves | 500 to 900 |
| 900 and 1800 series large 3x6 valves | 3000 to 5000 |
| 3" round and 2x3 valves with flow restrictors | 50 to 100 |

Regrinds are always lower than naturals. Bulk density will also cause wide variations in flow rates.

ERROR CORRECTIONS: RATE NUMBERS. (DATA line 2)

The RATE numbers are used by the software, each cycle, to calculate material dispense times. They are adjusted every cycle until flow rates stabilize. When a significant error is detected, the software adjusts the RATE numbers.

The GRAM number is adjusted first. The TIME number (interrupts) is changed only if either number falls above 32,768, or both fall below 16,384. In this event both GRAM and TIME numbers are doubled or halved until the larger of the two is between 16,384 and 32,768.

In other words, both numbers are kept as large as possible (up to 32,768) allowing for the most accurate math, but not so large as to overflow the registers.

Only the GRAM number changes from cycle to cycle, except under the conditions noted above.

Check the GRAM number for a series of consecutive cycles. If it remains unchanged, then the dispenses are accurate enough to not trigger error corrections. Another possibility is that the parameters (MI and NC) that determine when error corrections occur are somehow out of range preventing corrections that should be occurring.

The PRC parameter limits adjustments to 10 percent. Do not expect any single GRAM number change larger than 10 percent.

A gradual decrease in the GRAM number indicates a slowing rate, a hopper that is becoming empty for example. A jump in rate (increased GRAM number) occurs when the hopper is refilled.

If Errors are occurring, but the GRAM number is NOT adjusting, check the NC parameter and the MI parameter. These control whether or not error corrections occur. Both are set and adjusted automatically by the software. MI is set after each start up, after 10 cycles have run without retries. MI will be set to indicate 80 percent of normal dispense rate expressed as grams per second.

NC adjusts slowly over extended periods of running. NC indicates, in grams, the upper limit of the error in 60 percent of the dispenses. A high number usually indicates poor flowing material. Vibration or drifting load cells are other possibilities.

DISPENSE TIMING: (DATA line 3)

The second number is the number of interrupts calculated to dispense the material. If these times are consistent but the weight of the first dispense varies, then the material does not flow well, or consistently. Another possibility is excessive vibration or interference with the weigh bin.

Excess vibration, particularly on small dispenses, may cause incorrect weight readings even though the weight dispensed was, in fact, correct.

If the timing number is very small, 10, 20, 30 interrupts, perhaps this is asking too much from a slide valve. Very short times mean you want

small amounts, but are using a high rate dispense valve to do the job. An auger, a vertical valve, a horizontal valve with a flow restrictor, or a smaller valve would help to improve accuracy and control.

If the timing number is below 5, you are operating in a range where it is difficult for the blender to perform well.

The LAG time parameter adds time to every dispense. This is to compensate for the time at the beginning of a dispense when the solenoid valve shifts and air pressure builds, before the valve starts to move. LAG times are always set slightly longer than the necessary minimum. If a calculated dispense time is very short, the Lag time that is added, while small, may interfere with accuracy, and cause an over dispense.

PERCENTAGE ERRORS: (DATA line 1)

When looking at errors of percentage of color or additive dispensed, look further.

1. First, look for indications of "retries". Retries are evidence of a problem that will also cause percentage errors.

When FIRST time dispense, (DATA line 3), does not equal FINAL dispense, (DATA line 1), one or more retries have occurred. This means the hopper ran out of material, or the flow rate is so erratic that the first dispense was short for no good reason. Parameters `_RT` and `_RP` determine what shortage error is necessary to force a retry.

Inconsistent loading resulting in large variations in hopper material level can cause retries.

Excessive vibration can also cause bad weight readings, which can cause unwarranted retries. If the BAILOUT line is printing occasionally, then vibration is most likely causing this. Increasing the BAILOUT parameter should fix this.

A LAG time set too high may cause retries to overshoot their mark resulting in over dispensing.

2. Second, look at ACTUAL weight dispensed (DATA line 1).

Color, for example, is a percentage of the natural. In the example above, Natural is 1908.3 grams, so color, at 4 percent of Natural, is targeted to be 76.3 grams. In fact, 77.6 was dispensed. The error is 1.3 grams, well within the expected accuracy of a 1 inch auger feeder.

The actual GRAM error of a dispense is more meaningful than the percentage error. Mechanical devices are not perfect. The most we can expect from them is to operate within a reasonable range of accuracy. This range is better defined by an error expressed in grams, rather than percentage.

3. Third, look at the dispense TIME (DATA line 3).

Very short times (10, 20, 30 interrupts) indicate dispense devices not well matched to the task. Accuracy on a percentage basis, cycle to cycle, will suffer. This may very well be acceptable as long as overall usage percentages are still accurate.

BAILOUT: (line 4)

If bailouts occur, vibration is usually the cause and these bailouts may be causing other problems. Raise the value of the BAL parameter to 200 or 300 grams to reduce or eliminate unnecessary bailouts.

Vibration may also cause throughput rates to suffer due to the added time requiring to obtain acceptable weight readings. Increase the WDF parameter to 2 or 3 grams, (WDF 00003) or (WDF 00030), or more if necessary.

The last number in the last line is the CYCLE count, a convenient way to keep pages of data in order, like page numbers.

SPECIAL TESTS Using the *54 flag

If you are running special tests in the MANUAL or PROGRAM mode, a printout will automatically occur after each test provided the PRINT flag (*54) is turned on.

Special tests that produce printouts are TIME and CALIBRATE.

TIME (See KEYPAD, MANUAL MODE, TIME for more information)

The TIME function is to determine lag times of different metering devices. It also allows testing of device repeatability. The printout looks like this:

```
TIME      NATURAL      123      274.9
                ^dispense time (in interrupts; 244 = 1 sec.)
                ^weight dispensed
```

CALIBRATE (See KEYPAD, MANUAL MODE, CALIBRATE for more information)

The CALIBRATE function allows the controller to rapidly learn the flow rate of the device. It automatically sets the WEIGHT and TIME parameters that determine metering rate, and the MINIMUM RATE parameter. For more information see PARAMETERS, _RA, _TI, and _MI. The printout looks like this:

```
CALIBRATE NATURAL      732      2079.5      15      346.5
                ^dispense time
                ^weight dispensed
                ^lag time used
                ^min rate
```

MATERIAL USAGE INFORMATION

Pressing the VIEW key followed by the * key will cause all material usage totals to be printed. The (*54) flag need not be on. These totals are since the last time printed, and since the last time cleared.

This same information may be periodically, and automatically, printed by setting the PRT parameter to a time interval number. (See PARAMETER, PRT)

The printout looks like this:

| | DATE | TIME | TOTALS: | GRAND | PCT | CURRENT | PCT |
|----------------------|----------|----------|----------|--------|------|---------|-------|
| CURRENT | 11/01/90 | 18:26:45 | CYCLES | 83 | | 1 | |
| LAST PRINTED | 11/01/90 | 18:19:59 | REGRIND | 6.2 | .4 | 0.0 | 0 |
| LAST CLEARED | 10/30/90 | 20:02:36 | NATURAL | 1485.4 | | 19.0 | |
| | | | COLOR | 15.3 | 1.01 | 0.2 | 1.0 |
| WEIGH SCALE ID# 120 | | | ADDITIVE | 0.0 | .00 | 0.0 | .00 |
| TOTALS ARE IN POUNDS | | | TOTAL | 1506 | | 19 | |
| POUNDS PER HOUR | | | | | | | 286.2 |

The Totals may be in POUNDS or KILOS depending on your selection of weight unit using the *89 function in the PROGRAM mode.

The POUNDS PER HOUR is based on the total material throughput since the last time totals were printed. Cycle time variations will cause this number to not be exact. The longer the time period, the more correct the rate.

GRAND totals are totals since the last time the data was cleared using the *00 routine, or by pressing 00 immediately after executing this print routine.

CURRENT totals are totals since the last time a printout was obtained.

-----+
| PART IV - TROUBLESHOOTING |
+-----

WHAT TO DO

If you are reading this section, you are having problems. To locate and correct the problem we suggest that you take the following steps:

1. Start by reading the WIRING CONSIDERATIONS section. Even if the system worked well for a time, new wiring or increased plant electrical noise can cause new problems.
2. Then follow the CHECKOUT procedure in the front of this manual. If anything does not work right, read the diagnostics section that follows it.
3. Read the section on NORMAL OPERATING SEQUENCE to be sure you understand what it is supposed to be doing. If you are still unsure as to how the software logic works, call us.
4. Read the list of TYPICAL PROBLEMS that follows this list.
5. For difficult problems we can provide the most help if we have a printout of the PARAMETER table (KEYPAD, *77) and a cycle by cycle printout (KEYPAD, *54). (See PRINTED OUTPUTS section)

To print the PARAMETER table:

| | |
|--------------|------------------------------|
| Press: * | Display will say: (PASSWORD) |
| Press: 22222 | Display will say: (P x) |
| Press: *77 | Display will say: (INSTR 77) |
| | Parameter table will print. |

To print cycle information while the unit is running:

| | |
|----------------------|------------------------------|
| Press: * | Display will say: (PASSWORD) |
| Press: 22222 | Display will say: (P x) |
| Press: *54 | Display will say: (PRNT OFF) |
| Press: * | Display will say: (PRNT ON) |
| Press: EXIT 2 times. | |

6. If you have previously saved a correct copy of the parameter table using the *23 function, then do a "CLEAR" by pressing the "CE" key while turning POWER ON.
7. As a last resort, do a CLEARALL, (see CLEAR ALL section)

INCREASING THROUGHPUT

A correctly sized blender should have throughput that always exceeds your process requirements.

If, for some reason, your blender is not keeping up, here are a few ways to increase throughput.

1. If your blender is equipped with a flow control slide gate, under the blender, this will reduce throughput up to 25 percent. To counter this, set the "END FULL" flag on using the *44 function explained earlier. In the END FULL mode, blending begins even while the sensor is still covered due to flow control valve operation.
2. If your process consumes a large batch of material all at once (such as during injection and screw return time), and material reserve is not adequate, you may "run out" of material for a few seconds while the Weigh Scale blender is making a new batch. The *44, "END FULL" function will also correct this. Here, when the sensor is uncovered, a completed batch is immediately available to help refill the mix chamber, providing a larger reserve to the process.
3. Increase the FUL parameter. This sets the batch size. Larger batches increase throughput. Depending on the bulk density of your material, you may be able to increase batch size by 20 to 40 percent.
4. Reduce the DTI parameter. This is the number of seconds the weigh bin opens to empty each batch. Shorter DTI times will shorten the overall cycle time and increase throughput.
5. Turn "FAST" on. This causes rapid volumetric "timed" dispenses to occur up to 4 times after each normal gravimetric dispense.
6. Do not confuse "reserve" with "throughput". If your blender has a temporary problem which results in your process running out of material before you have time to remedy the problem, your "reserve" is inadequate. Add a surge hopper, or material level alarms on individual hoppers to prevent these types of problems.

TYPICAL PROBLEMS

These problems are based on phone calls that we have received from GB/WSB Autoweigh Blender.

The display does not read close to zero when power is turned on, bin empty (plus or minus 10 grams).

- * The load cells are not plugged in.
- * The weigh bin is not resting properly and freely in its platform or the platform is not resting properly on the bolts that protrude from the load cell enclosures.
- * The controller was never calibrated for these load cells or you just did a CLEAR ALL. In this case it will most likely read about 400 grams. See LOAD CELL CALIBRATION.
- * The load cells are damaged. See CHECKING THE LOAD CELLS

The Controller "RESETS" itself for no reason. This indicates electrical noise or voltage spikes disrupting the processor.

- * See WIRING CONSIDERATIONS, ASSEMBLY section.

The ALARM is flashing and the display shows a weight above 100 or below -50 grams. If above 100, the Weigh bin dump valve keeps opening and closing every 6 or 7 seconds. * There is material in the weigh bin that will not dump out.

- * The dump flap may be stuck.
- * The load cells are hung up or obstructed.
- * The load cells are out of calibration.
- * Incorrect grounding is causing wide load cell readouts.

The VERY FIRST DISPENSE does NOT take place. After a few seconds the ALARM begins to flash. The display says (N x.x) and is flashing.

- * The air supply is not connected or the pressure is set too low.
- * The Natural solenoid is not connected properly.
- * The 1/2 amp panel front fuse is blown.
- * The NATURAL air cylinder is jammed. Maybe the mount is bent.

The NATURAL dispense valve continues to dump repeatedly even though the weigh bin has filled to overflowing. The weight reading is still below 2000.0 grams.

- * The weigh bin is not free to move.
- * The load cells are jammed.
- * The load cells are damaged. See CHECKING THE LOAD CELLS

The system operates but always needs MANY RETRIES to complete a dispense and never seems to "learn" the proper dispense rate.

- * The Minimum rate parameter is set to high. To correct, turn power off and then on again. The software will recalculate this parameter within the first 10 or 20 cycles.

The THUMBWHEEL SWITCHES do not seem to be controlling output. One or more LEDs (3 at bottom right) are on all the time.

- * Someone has LOCKED IN a setting using the keypad. See KEYPAD, PROGRAM MODE, SETTING.
- * The _SE parameter is LIMITING the thumbwheel switch setting. See KEYPAD, PROGRAM MODE, and PARAMETERS, _SE.

Occasionally, the system gets STUCK doing retries of a component but the retry time is so short that nothing gets dispensed.

- * The LAG TIME parameter is set for too short a time. See KEYPAD, TIME, and PARAMETER, _LA.
- * The dispense valve is sticking, slightly delaying it's opening. The time period is too short for the valve to begin moving.

The system USED TO WORK but now it does unexplainable things.

- * Static or a voltage surge has altered RAM memory. Do a CLEAR or CLEAR ALL. See "CLEAR" RESTART or "CLEAR ALL" RESTART. After a "CLEAR ALL", LOAD CELL CALIBRATION is necessary.

The Display reads 3100.0 even with the bin empty. This is the upper limit load cell readout.

- * The Load Cells are not plugged in and the circuitry has drifted to the top limit.
- * The load cells have been overloaded way beyond their limit and are now permanently deflected.

Dispenses from a slide gate are not as consistent as they should be. * The slide gate is sticking slightly. With the hopper empty, move the slide manually to see that it moves freely. Press up or down on the air cylinder to adjust for proper alignment.

- * The material does not flow very well. A bridge breaker adaptor may be required.

Load Cell weight readings are not holding steady. They vary as much as 100 grams from second to second.

- * This is static and improper grounding. See WIRING CONSIDERATIONS
- * If readings drift slowly in one direction, requiring frequent recalibration, a component on the circuit board is most likely faulty. Call us.
- * If TARE weights are not steady, something may be physically interfering with free movement of the cells.

The Weigh Bin dump valve does not stay open long enough for the bin to empty fully.

- * The air flow control valve is adjusted too far in and the valve opens too slowly. This should be adjusted to slow the closing just enough to prevent excessive banging.
- * The DTI parameter is not set for enough dump time. This parameter controls Dump Time (DTI). Recommended times are 2000 grams = 6 sec.; 4000 grams = 10 sec.; 9000 grams = 4 sec. Entries are in seconds. See PARAMETERS for more information.

The MIX MOTOR runs when set to ON but not when set to TIMED.

- * The fuse on the RELAY circuit board is blown. See hardware maintenance for replacement instructions.

NORMAL OPERATING SEQUENCE

This section tells you how the system is supposed to work. If your system is not operating correctly, this description may help you spot exactly where the system is failing, providing a clue to the problem.

Turn POWER ON:

The following displays occur for 1 second each: Program version date (V=21031A), the check sum number (CKS XXXX), ROM check (ROM OK), RAM size, (RAM = 8K), Model number (MODEL220), display of (0.0), actual weight in the bin is displayed last. It should be close to 0.0, plus or minus several grams.

BEGIN operation:

The unit will begin to operate if both switches on the left side are UP in the CONTINUE position and the SENSOR in the mix chamber is UNCOVERED. The sensor must be plugged into the right side of the controller. If it is not, this has the same effect as the sensor being covered; the unit will not run. If the sensor LED (on the sensor) is on, the sensor thinks it is covered. If it is sensing incorrectly, adjust the sensitivity. See ADJUSTMENTS.

If the WEIGH BIN DUMP Flap opens and closes repeatedly:

If initial empty bin TARE weight is 100 grams or more, the weigh bin dump valve will operate in an attempt to empty the bin and bring the starting weight closer to zero. If the bin is empty but the weight reading is greater than 100 grams then something is wrong. See TESTING the LOAD CELLS and LOAD CELL CALIBRATION.

If the ALARM flashes:

If the initial TARE weight is below -50 grams the Alarm will flash and the unit will not operate. go to TESTING of LOAD CELLS and LOAD CELL CALIBRATION.

The DISPENSE sequence begins:

If initial tare weight is within limits, between -50 and +100, the sequence will begin.

DISPLAY during dispenses:

During all dispenses, the letter R, N, C, or A will be displayed indicating which component is being dispensed. The INITIAL display is the tare weight of the bin. This will not change during the dispense. Three seconds after each dispense, the new total weight of the material in the bin is updated and displayed.

REGRIND first:

If REGRIND has been requested the REGRIND dispense will occur first. The letter "R" will appear in the display. After this dispense an exact weight is taken to determine the space remaining in the weigh bin for the remaining dispenses. The weight of REGRIND dispensed will appear in the display 3 seconds AFTER the dispense has ended.

NATURAL second:

The NATURAL dispense occurs next in the sequence. The letter "N" will appear in the display. The exact weight of the NATURAL dispensed is now determined for calculating the COLOR and ADDITIVE dispenses. The TOTAL weight of NATURAL and REGRIND combined will appear in the display 3 seconds AFTER the Natural dispense has ended.

COLOR third and ADDITIVE fourth:

COLOR is dispensed followed by ADDITIVE as requested by the thumbwheel switch settings. Each dispense must meet requirements set by internal parameters or RETRIES will occur and the sequence will not continue.

MATERIAL RUNS OUT:

If any material runs out or is not enough to meet criteria set by the internal parameters then the process will NOT CONTINUE past this component. RETRIES of this dispense will occur indefinitely until the full dispense occurs or power is turned off. The display will FLASH. The ALARM will sound after 4 retries. This number of retries before alarm is based on the ALARM (_AL) parameters. REGRIND may, or may not, be set to ALARM when it runs out. See PARAMETERS, (RAL 00000), to change this.

If ALARM flashes:

More than four retries of any single component will cause the strobe light ALARM to begin flashing. The component that is causing the alarm will continue to retry the dispense. The display will blink and the LETTER in the display will signify which component is causing the problem. To continue with the dispense sequence, you must satisfy the requirements of the dispense or turn power off.

WEIGH BIN dump:

After all dispenses the weigh bin is emptied by the final dump of the weigh bin into the mixing chamber. The dump valve remains open for six seconds.

SENSOR covered:

While the sensor is covered, the dump valve remains open to ensure the weigh bin empties completely. Dispensing stops. The dump valve will remain open for as long as the sensor is covered. Uncovering the sensor will begin the next cycle.

FLOW CONTROL Valve: (optional)

If your unit has a Flow Control Valve under the mix chamber, this valve will stay closed for the 6 seconds immediately following a dispense into the mix chamber. (time is based on the FCV parameter). At all other times it opens when the sensor is covered, and closes when the sensor has been uncovered for 2 full seconds.

VERIFYING LOAD CELL FUNCTION

Most Problems are related to LOAD CELL function.

There are several ways to VERIFY that the load cells are functioning properly. The slightest touch on the weigh bin should result in a change in the readout. If this is not the case, something is wrong. When the light touch is removed, the display should return to its starting point. If this does not happen, something is interfering with free movement of the cell or the bin. Make a careful inspection of EVERYTHING around the load cells, the hanger bolts, the weigh bin tray and the weigh bin. NOTHING should interfere with free movement.

NOTE: It is normal for load cell readout to drift several grams over time and with different temperatures. Since all the component dispenses are weighed by a single set of load cells, this drift will affect all components equally and, therefore, the ratio of the components will remain accurate. Empty weight is always TARED so each dispense is accurately measured.

The following observations will verify proper load cell operation:

When the bin is empty, between cycles, the display should read near zero. An error of several grams is not important since this empty weight reading is "tared" from all dispense readings. The "empty weight" readings should be consistently within 1 or 2 grams.

The addition of several pellets to the weigh bin should result in a change in the readout. 1/10 of a gram is about four pellets, a gram about forty. This should hold true when the weigh bin is full as well as when it is empty.

Most load cell problems are caused by interference to the movement of the load cell. The load cell must be free to respond to the weight of a single pellet as well as free to move far enough to record full load cell rated weight deflection.

If weight readout is very erratic check for damage to the load cell wires. Check for a pinched wire in the connector.

An over-stressed load cell will read high. The top limit is (3100.0) for a GB/WSB2xx and (22444) for GB/WSB4xx or GB/WSB9xx. A load cell that was forced or pried upward to far will read (0.0).

We supply and replace load cells in matched sets and we always include the mounting enclosures. You may remove the back plate from the enclosure for visual inspection. It is not safe to remove the load cell itself from the enclosure. To do so may stress the cell itself.

To operate with damaged load cells, see KEYPAD, *87, VOLUMETRIC.

To RECALIBRATE the LOAD CELLS, see the MAINTENANCE MANUAL.

For further information, see the next page, RAW SIGNAL READOUT, and Following page, LOAD CELL plus WEIGH BIN TEST.

LOAD CELL RAW SIGNAL READOUT

Press "CE" key to check this RAW number for several seconds.

Load cells put out a very small voltage that varies slightly as the load cell is deflected. This voltage is converted, on the circuit board, to a pulse train and these pulses are counted for 1 full second to determine a weight load. The software can handle a range of counts from 0 to approximately 249,850.

A properly operating set of cells will range from about 55,000 to 120,000; a span of about 65,000 from empty weight (weigh bin in place), to a full bin weight of 2000 grams. (10 K load cells range about 90,000 from empty to 9000 grams). The system will work correctly as long as the empty bin weight readout is between 1 and 149,248. 149,248 is the highest number that the software will accept for zero weight calibration (see parameters, LCZ). If the number is over this when you press the ZERO weight key, the display will say (ZERO LOW).

This RAW COUNT number is converted by the software, based on the load cell calibration information, to the proper gram readout.

The RAW COUNT numbers are more useful in diagnosing load cell problems because they eliminate any calibration errors that might have occurred.

Press "CE" key to display this RAW number for several seconds.

To observe this number continuously, use the *98 function in the PROGRAM mode.

```
+-----+
| Press: *           Display will say: (PASSWORD) |
| Press: 22222       Display will say: (P      x) |
| Press: *           Display will say: (INSTR __) |
| Press: 98          Display will say: (CNT OFF ) |
| Press: *           Display will say: (CNT ON  ) |
| Press: EXIT        Display will say: (P  xxxxx) |
+-----+
```

A floating, drifting number usually indicates the load cells are not plugged in.

A readout of 0 indicates an open circuit, a damaged wire or cell.

A full scale readout of 249,850 indicates a damaged wire or cell.

A set of 3 K load cells will put out about 33 more counts for every gram of weight that is added. A test of sensitivity is to add a small weight to the bin. The RAW WEIGHT count should increase by about 33 counts for each gram added. (10 counts per gram for 10K load cells.)

If you call us for help in solving a load cell problem, it is helpful if you can tell us what the RAW COUNT number is with the bin empty, and with a known weight in it. Pressing the CE key at any time will display the RAW COUNT number for the current weight.

To OPERATE with DAMAGED load cells in a VOLUMETRIC mode, see KEYPAD, *87, Volumetric mode.

LOAD CELL plus WEIGH BIN TEST
to verify correct operation

This test is to help you determine if the load cells are working correctly, and if the weigh bin and weigh bin hanger are moving freely and registering weight correctly.

Have a pad and pencil ready to write down the weight readings that appear on the display, both before and after each dispense. If you prefer, you can use a printer to record all test data. Have the printer flag (*54) set to ON.

Be in the PROGRAM mode. (*22222).

1. Start with an empty weigh bin.
2. Dispense a very small amount, using the TIMED DISPENSE function:
Record the weight display.
Press: TIME, NAT, 040
Wait for dispense then record the new weight.

Wait for test to finish, about 10 seconds. At the end of this test the bin will automatically empty.

3. Now, manually add enough pellets to bring bin weight up to the approximate full batch weight. Do this by pressing on the small air solenoid operator pin for NATURAL. Drop in enough pellets to be close to a normal full batch weight, like 2000 or 4000 grams. Exact weight does not matter. We just want to place the approximate full batch weight on the load cells.
4. Repeat step 2, recording the weight readings.
5. Do this entire test 3 more times.
From the weight readings, calculate the weight of each dispense from each test.

RESULTS TO EXPECT:

In each test, the first timed dispense, when the bin is empty, should be very close or equal to the second dispense, when the bin is full. Results from all 4 tests should be very similar.

If the second dispense is always less than the first, the load cells are suspect. The enclosures may be full of pellets. Weigh bin interference is also possible. If all dispenses vary widely with no pattern, this is most likely caused by weigh bin interference. Weigh Bin interference is usually visible with close inspection.

"CLEAR" ROUTINE

A "CLEAR" routine is available that will clear all data, flags, and all other current information from memory. Since MEMORY is battery backed up, turning power off does not clear all fields. A great deal of information is intentionally held for later use. A "CLEAR" routine will clear all RAM data and start with the information stored in the EEPROM. This is the same data that existed when new or data that you may have intentionally saved earlier. All current rate calibration numbers that the unit has "learned" will be overwritten.

To execute a "CLEAR", hold down the "CE" key while turning POWER ON, then release. When done correctly, the display will say (CLEAR).

CLEAR does not clear EEPROM information but instead loads EEPROM into RAM. Load Cell weight calibration numbers are NOT lost.

(To load EEPROM with correct RAM information, see KEYPAD, *23)

CLEAR ALL - RESTART

The same as the CLEAR, above, but EEPROM information is also cleared. There are only TWO times when you want to do a CLEAR ALL.

1. When a NEW PROGRAM CHIP has been installed.
New chips often have different PARAMETER table layouts. Information may reside in memory locations that do not match the new program. CLEAR ALL - RESTART fixes this.
2. When all else fails.
CLEAR ALL - RESTART will sometimes fix problems that the simple CLEAR routine misses.

The keys to press on power up are VIEW, BTCH, and EXIT (Top row, left, center, and right). Hold all three down as power is turned on, then release. When done correctly the display will say (CLEARALL).

LOAD CELL calibration WILL be lost. You will have to follow the Load Cell calibration procedure given in this manual.

Since parameter table information is lost, you will want to reenter parameters that were previously modified. See BRIEF EXPLANATION of PARAMETERS for a quick review of which ones might have been changed.

Be certain that your unit displays the proper MODEL number when you turn on power. If not, see SELECTING CORRECT MODEL, page 14.

CORE DUMP

During production or between cycles, the controller can be forced to print a CORE DUMP of Memory. This is helpful to us when elusive problems are occurring related to non predictable environmental problems. If you are having reoccurring problems, we may ask you to use this routine during production to help us diagnose the problem.

To obtain a MEMORY CORE DUMP, have a printer connected. Press three keys at the same time; the PARA, FULL, and ALRM keys; bottom row, left center and right.

-----+
| PART VI - HARDWARE MAINTENANCE |
+-----

HARDWARE ADJUSTMENTS

AIR PRESSURE

Set AIR PRESSURE to about 80 PSI for best accuracy. However, lower pressures will work. If you plant air fluctuates, set the regulator to the low end so that the dispense valves always see a consistent pressure. Lubricated air is NOT recommended. Micro Blenders should be set to 40 PSI (2.7 bar). Vertical Valves used in removable hoppers on Micro Blenders, and 100 and 200 series blenders, are more accurate at 60 PSI pressure setting.

LEVEL SENSOR

Sensor position:

On 200 and 400 models, the sensor should protrude into the mix chamber about 1/4 inch past the inside surface of the stainless mounting plate. If it does not protrude far enough, it will sense the mounting plate itself. If it protrudes too far, it will sense the mix blade. Relocate if necessary.

Adjusting sensor sensitivity:

1. A sensor adjustment is located on the back of the sensor. A small thin screwdriver is required. Some sensors have a black plastic cover that must be removed for access to the adjusting screw.
2. Fill the mix chamber until the sensor is about 3/4 covered.
3. Turn screw counter-clockwise until the LED goes OFF.
4. Then turn clockwise until the LED just goes ON.
5. Empty the chamber and check to be sure the sensor LED stays OFF when the mix blade passes near it.
6. If applicable, replace the plastic access cover screw.

NOTE: 18 mm sensors, LED logic is reversed, ON when UNCOVERED.

WEIGH BIN DUMP VALVE (SOFT CLOSE)

The WEIGH BIN DUMP VALVE should be adjusted to close softly. An air flow needle valve is installed near the quick disconnect so that air flow to the weigh bin air cylinder may be restricted. Adjust as required for a soft close.

SLIDE VALVES

Slide valves must move very freely. If they seem to jam slightly in the full extended position (closed), this may be due to the cylinder mount being bent. Lifting the blender by the air cylinders, or standing on them will cause this. You can correct this by pressing up or down on the cylinder as required to straighten the mount.

If you process very hard pellets (polycarbonate and glass filled resins), your slide gate dispense valves may stick closed occasionally. We provide spacers that limit the full stroke of the air cylinder. This stops the slide from going any further than the just closed position and prevents jamming. Call us for information.

INTERNAL MIX MOTOR and AUGER FEEDER FUSES

The MIX MOTOR and AUGER FEEDER OUTLETS are driven by internal solid state plug-in relays. 5 amp glass fuses are located to the right of each relay. A spare fuse is also located on the board.

CLEAN OUT ISSUES

We always try to design with clean out in mind. For this reason all models have removable weigh bins, mix blades, and mix chambers. Selected models have additional clean out issues.

GBM Micro Blenders and all blenders with removable hoppers use our vertical or pivot style valves. Most pivot valves are fitted with a sleeve over the air cylinder that shields the dispense valve when it is retracted. Dust can accumulate under this sleeve, between the sleeve and the air cylinder. To clean, remove the air fitting on the cylinder. This fitting is all that retains the sleeve on the cylinder. With the fitting removed, one inch sleeves will drop out the bottom of the hopper, free of the cylinder. Larger sleeves require the cylinder be removed from the mounting bolt, and the sleeve lifted upward off the cylinder.

MIX PROBLEMS

Customers with mix problems have several options available.

1. Decrease the batch size by lowering the FUL parameter value. This does two things. First, it causes the components to be dispensed in smaller, more frequent batches which places more and smaller layers of material into the mix chamber. Second, it lowers the level of material in the mix chamber immediately after a dispense. For proper mixing it is critical that the mix blades reach up through the top of the material in the mix chamber during mix time. Dispensing a large batch may bury these blades, particularly when the process is not running at full blender capacity. A smaller batch size, while reducing throughput rate, will help prevent the mix blades being covered during mix time.
2. Be sure level sensor is mounted in its lowest position, and increase sensitivity as much as possible. Both serve to keep a batch from being dispensed so early as to cover the mix blades.
3. On units without flow control valves (FCA) increase the DLY parameter to a number as high as 50 percent of the time between cycles. DLY is the time delay (in interrupts) from the sensor being uncovered until we begin the batch. Increasing DLY allows the mix chamber to empty somewhat before the next batch drops. The maximum possible value for DLY is 29999 or 122 seconds.
4. You may increase the mix time at the end of each batch by changing the last two digits of the MIX parameter. If throughput is very high it may be better to run the mixer continuously. However, added mix time sometimes causes separation after an initial mixing. Different bulk densities and static electricity both aggravate this potential for separation from excessive mixing.
5. If a blender is mounted on a stand over a surge hopper, there should be a FCA, automatic flow control valve, fitted to the bottom of the blender. This valve must be plumbed so that it is closed when the level sensor is uncovered. When the sensor is covered the valve opens to release material. The purpose of this valve is to ensure mixing. The FCV parameter delays the opening of this valve for 6 seconds. You can increase this delay time if you feel additional mixing is required before release.
6. On model GB/WSB-940, be sure the weigh bin has two baffles installed. These ensure horizontal layering (as opposed to side by side layering) of materials prior to dropping into the mix chamber.
7. Bulk density and pellet shape differences, specifically smooth virgin pellets mixed with square higher density color pellets, can separate when dropped onto a sloping pile, as exists in a hopper, Gaylord, or surge bin. The light round pellets flow like water to the edges, while the heavier square color pellets stay put. This is difficult to correct. It is best not to drop these kinds of blends into large containers.
8. Vacuum conveying can also separate materials of different bulk densities. Maintain high air velocity to minimize this.

9. Models GB/WSB-GBM, 100 series, and some 200 series units use an air drive for the mix blade, instead of an electric motor.

Air drives have these advantages:

- a) Improved mixing due to back and forth motion of the blades.
- b) No EMF (Electro Magnetic Force) feedback to the processor from electrical demands of the motor resulting, the results in less processor problems.
- c) Less electronic parts on the board, parts that are vulnerable to failure from in-plant voltage spikes, from storms and power failures, parts that can represent a percentage of failures over the lifetime of the blender.
- d) Inherent safety for plant personnel due to the more controlled, more limited torque of an air drive compared to an electric motor drive. A correctly sized electric motor can deliver 10 times the normal design and operating torque when stalled. In spite of interlocks, this presents a potential safety hazard.

If you are having mix problems with air drives, be sure the blades moves a full 270 degrees (3/4 turn) with each sweep. If they do not, try the following:

- a) Increase the air pressure. If the gauge pressure drops more than 5 pounds during operation of the blades, the air supply line is too small.
- b) Lower the pile in the mix chamber to reduce torque requirements on the mix blade. This is explained above.
- c) Increase the MPO parameter from 122 (1/2 second) to 183 (3/4 second) or 244 (1 full second). This allows more time for a full mix blade sweep to occur. You may also want to increase mix time from 10 seconds to 15 or 20 seconds so that, in spite of slower mix blade speed, the same amount of mixing occurs.

RECALIBRATION OF LOAD CELLS

This unit was calibrated at the factory to match the load cells that were supplied with it. If you recalibrate, note the following:

Recalibration can not be done until the Recalibration flag is turned ON. The proper sequence of keystrokes is given below.

BE SURE the load cell plug is plugged into the side of the controller.
BE SURE the weigh bin is hanging from the load cells freely.
BE SURE the air line to the dump valve is connected as it would be during normal operation. (A disconnected air line adds weight.)
Air pressure to the line is not necessary.
BE SURE there is nothing touching the weigh bin or air line.
BE SURE the bin is EMPTY when ZEROING the load cells,

ZERO WT. must be done before FULL WT. Since changes in ZERO WT will also shift the FULL WT scale by the same amount, it may not be necessary to go any farther than this.

When SETTING FULL WEIGHT, BE SURE you know the exact weight (in GRAMS) that you are adding to the bin. Place this weight in the bin and then press the FULL WT. key. Five dashes (FUL-----) will be displayed. Enter the EXACT weight in GRAMS that you have placed in the bin. The weight should be close to the design full batch weight for your system, (400, 1000, 2000, 4000, 9000, or 18000 grams).

When done, there is no need to turn the Calibration Flag off. The next time power is turned off this flag will be reset to OFF.

The sequence of keystrokes is as follows:

```
+-----+
| Press:  *           Display will say:  (PASSWORD)
| Press:  22222       Display will say:  (P   x.x)
| Press:  *99        Display will say:  (CAL  OFF)
| Press:  *           Display will say:  (CAL  ON )
| Press:  EXIT       Display will say:  (P   x.x)
| Press:  ZERO       Display will say:  (--WAIT--)
|                   followed by:  (P   0.0)
|
| Place the correct weight for your model in the bin.
|
| Press:  FULL       Display will say:  (FUL-----)
| Press:  2000       Display will say:  (--WAIT--)
|                   followed by:  (P 2000.0)
|                   If YOUR weight is not 2000 grams,
|                   enter the ACTUAL weight that YOU use.
|
| Press:  EXIT       Display will say:  ( 2000.0)
| Remove weights:   Display will say:  (    x.x)
|
| Actual displayed weights may be plus or minus a few grams.
+-----+
```

After FULL weight calibration, if the display says (BAD CELL), the weight you are using does not match the weight you entered, the weigh bin is not free to move, OR the load cells are bad.

BLENDER PREVENTIVE MAINTENANCE

There are no components of your blender that require periodic maintenance. However, over the years, blenders may be subjected to abuse or difficult conditions, and accuracy can suffer. To maintain control over the cost of expensive color and additives, you must maintain accuracy. We recommend that blenders be examined once a year, and all necessary repairs be made to insure continued accuracy.

DISPENSE GATES

To be accurate, gates must open and close freely, quickly, and completely. Check for wear on the slide gate guide rods. Check cylinder clevis adjustment for correct closing of the gate. A gate should close just enough to block the hole, but no further. It is best if they do not pass over the far edge of the opening as this might catch and jam on a pellet. Check that the clevis pin connecting the air cylinder is intact, not broken or worn through. Check for correct air pressure, tight fittings, and no damaged or crimped air lines.

LOAD CELLS

It is a good idea to remove the load cells, remove the back cover off each enclosure, and inspect for contamination that might have entered and built up over time. Do not remove the load cell from its mounting. Just blow out any contaminants. Load cell enclosure design has evolved over the years. If you find significant contamination, request new enclosures from us. MB and 100 series have recently improved enclosures, since 2000. Other models had improvements made before 1997. We will provide these parts for free if you need them.

WEIGH BINS

Check for smooth correct operation of the dump flap. Hinge points should not be worn. Gate should overlap the forward edge enough to prevent dribble when closed, even when closed against pellets. Space at the rear of the flap should allow for static build up of pellets on the rear edge of the dump flap without interfering with the closing of the flap. Again, if you see evidence of these problems, newer design parts are available to solve these problems. Check that the flap closes fully, and closes softly. The soft close is adjustable.

CLEARANCES - FREE MOVEMENT OF WEIGH BIN.

Carefully examine all the parts of the weigh bin and the bin hanging bracket to be sure that nothing touches any fixed parts. A quarter (1/4) inch of space should exist on all sides of the weigh bin. Over the years, windows and guards have been added, and this has required that the weigh bin size be reduced to maintain 1/4 inch clearance per side. Be sure you do not have an older larger bin installed where windows have been added.

A light touch of the bin should show a change in the weight readout. Remove the touch and the display should return to exactly the same number, plus or minus 1 or 1/10 gram depending on model. Only the last digit should drift, or vary, and by no more than one count. If ANY interference is detected, it MUST be fixed.

MIX CHAMBER

No bent blades. No SHARP blades. Bent blades might brake off and severally damage your process screw. Sharp blades are a safety hazard. Replace if mix blades are not perfect.

The blade assembly should slip on and off the motor shaft easily. The need to use excessive force to remove the mixer assembly may bend the blades and they may eventually break off. Correct this if it is a problem.

*77 and *54 PRINTOUTS

After you have fixed any problems, use the *77 and *54 functions to obtain printouts and fax them to us for evaluation.

MODEL GT - Autoweigh TOTALIZER

THESE INSTRUCTIONS FOR "TOTALIZERS" ONLY

Conair Autoweigh Totalizers track the exact weight of material that passes through the unit.

They operate exactly like Autoweigh Blenders except that only one component is dispensed. Because of this difference, Totalizers are mechanically much simpler than blenders. The differences are the single compartment material hopper and the elimination of the mixing chamber.

Totalizers use the same software as blenders. This manual is correct for the software provided in a Totalizer. However, since there is only one component, totalizers are very simple to operate. All thumbwheel switches are always set to zero. In this way only Natural is dispensed. Natural does not require a setting. With all other component settings on zero, Natural is dispensed as 100 percent of the "blend".

The TUTORIAL covers basic instruction on operating the controller. The INSTRUCTION MANUAL covers the set-up and check out procedures.

Remember: For TOTALIZERS, as you read this manual, ignore all reference to Re grind, Color, and Additive. You are concerned with the NATURAL component only. Also ignore references to the mix chamber.

Basic operation:

Leave all thumbwheel switches on zero.

Turn unit on; POWER, PAUSE, and STOP switches up.

As material is dispensed and weighed, totals will accumulate in the controller memory.

You may retrieve these totals at any time by:

1. using the VIEW key for direct read out on the display,
2. using a printer for a printed record,
3. using our MLAN software to port all information to a computer,
4. set unit to continuously display the total through-put (see next page).

Read this instruction manual for more information on these options.

SPECIAL TOTALIZER FUNCTION

A special function is available that allows throughput TOTALS to be displayed at all times. This flag is for TOTALIZER models only.

When set, the display will continuously display the total amount of material that has passed through the unit since the total fields were last cleared. When the unit is functioning as a totalizer, this is the information that is most meaningful.

Since totalizers do not blend, this flag also causes all settings to be set to zero whenever power is turned on.

To reset the totals to zero:

First, stop operation by switching to "STOP END OF CYCLE".

Next, switch to "IMMEDIATE PAUSE".

Last, press "ALARM SILENCE" to clear the totals.

We may have already set this flag.

If we did not, the sequence of keystrokes is as follows:

```
+-----+
| Press: *           Display will say: (PASSWORD) |
| Press: 22222       Display will say: (P  x.x) |
| Press: *47         Display will say: (BLENDER ) |
| Press: *           Display will say: (TOTALIZE) |
| Press: EXIT        Display will say: (P  x.x) |
| Press: EXIT        Display will say: (  x.x) |
+-----+
```

This page to be replaced with the WIRING DIAGRAM pages

COMPUTER OUTPUTS - WIRING SUPPLEMENT

17 pin connector

This computer output;

```
|      drives this device on the board;
|      |      that goes to the outside world through this connector;
|      |      |      to drive this external device.
|      |      |      |      wire color
```

formerly optical coupler outputs

| 17 pin Amphenol connector

| | | | | |
|---|---|-------|--------------------------------|--------|
| 1 | 1 | pin A | weigh bin dump air solenoid | brown |
| 2 | 2 | pin B | component 1 air solenoid | orange |
| 3 | 3 | pin C | component 2 air solenoid | blue |
| 4 | 4 | pin D | component 3 air solenoid (add) | gray |
| 5 | 5 | pin E | component 4 air solenoid (col) | purple |
| 6 | 6 | pin M | flow control air solenoid | yellow |
| 7 | 7 | pin F | component 7 air solenoid | red |

solid state plug-in relays (4) on separate board

| | | | | |
|----|---|--|-------------------------------------|------------|
| 8 | 1 | comp. 5 - additive auger motor outlet, panel front | | |
| 9 | 2 | comp. 6 - color auger motor outlet, panel front | | |
| 10 | 3 | strobe and beeper + opt. alarm relay output | | |
| 11 | 4 | mix motor outlet, panel side | | |
| 12 | 5 | pin G | comp. 8 - external SS relay | wt./red |
| 13 | 6 | pin H | comp. 9 - external SS relay | wt./yellow |
| 14 | 7 | pin J | comp. 10 - external SS relay | wt./green |
| 15 | 8 | pin K | comp. 11 - external SS relay | wt./blue |
| | | pin L | alarm | |
| | | pin N | common line, all outputs. +24v | white |
| | | pin P | comp. 12 (also air drive mixer) | |
| | | pin R | neutral to 10 volt signals (S,T) | |
| | | pin S | 0-10 volt extruder control signal | |
| | | pin T | 0-10 volt line speed control signal | |

External SS relays are optional.

External SS relays and air solenoids may be exchanged.

Conair has made the largest investment in customer support in the plastics industry. Our service experts are available to help with any problem you might have installing and operating your equipment. Your Conair sales representative also can help analyze the nature of your problem, assuring that it did not result from misapplication or improper use.

WE'RE HERE TO HELP

To contact Customer Service personnel, call:



From outside the United States, call: 814-437-6861

You can commission Conair service personnel to provide on-site service by contacting the Customer Service Department. Standard rates include an on-site hourly rate, with a one-day minimum plus expenses.

HOW TO CONTACT CUSTOMER SERVICE

If you do have a problem, please complete the following checklist before calling Conair:

- Make sure you have all model, serial and parts list numbers for your particular equipment. Service personnel will need this information to assist you.
- Make sure power is supplied to the equipment.
- Make sure that all connectors and wires within and between control systems and related components have been installed correctly.
- Check the troubleshooting guide of this manual for a solution.
- Thoroughly examine the instruction manual(s) for associated equipment, especially controls. Each manual may have its own troubleshooting guide to help you.
- Check that the equipment has been operated as described in this manual.
- Check accompanying schematic drawings for information on special considerations.

BEFORE YOU CALL ...

Additional manuals and prints for your Conair equipment may be ordered through the Customer Service or Parts Departments for a nominal fee.

EQUIPMENT GUARANTEE

Conair guarantees the machinery and equipment on this order, for a period as defined in the quotation from date of shipment, against defects in material and workmanship under the normal use and service for which it was recommended (except for parts that are typically replaced after normal usage, such as filters, liner plates, etc.). Conair's guarantee is limited to replacing, at our option, the part or parts determined by us to be defective after examination. The customer assumes the cost of transportation of the part or parts to and from the factory.

PERFORMANCE WARRANTY

Conair warrants that this equipment will perform at or above the ratings stated in specific quotations covering the equipment or as detailed in engineering specifications, provided the equipment is applied, installed, operated and maintained in the recommended manner as outlined in our quotation or specifications.

Should performance not meet warranted levels, Conair at its discretion will exercise one of the following options:

- Inspect the equipment and perform alterations or adjustments to satisfy performance claims. (Charges for such inspections and corrections will be waived unless failure to meet warranty is due to misapplication, improper installation, poor maintenance practices or improper operation.)
- Replace the original equipment with other Conair equipment that will meet original performance claims at no extra cost to the customer.
- Refund the invoiced cost to the customer. Credit is subject to prior notice by the customer at which time a Return Goods Authorization Number (RGA) will be issued by Conair's Service Department. Returned equipment must be well crated and in proper operating condition, including all parts. Returns must be prepaid.

Purchaser must notify Conair in writing of any claim and provide a customer receipt and other evidence that a claim is being made.

WARRANTY LIMITATIONS

Except for the Equipment Guarantee and Performance Warranty stated above, Conair disclaims all other warranties with respect to the equipment, express or implied, arising by operation of law, course of dealing, usage of trade or otherwise, including but not limited to the implied warranties of merchantability and fitness for a particular purpose.

SPECIFICATIONS

GRAVIMETRIC BATCH BLENDERS
Autoweigh GBM Series Models

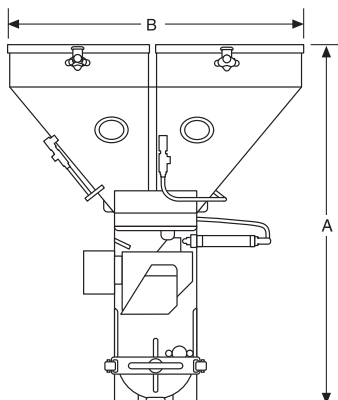

IBO6 Loader Mounting Interface
 6.5 in {165 mm}

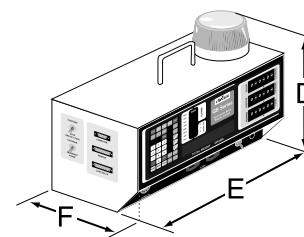
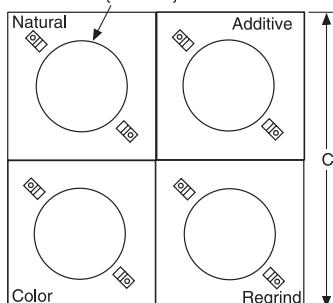

CONTROL (REMOTE MOUNTED)

| MODELS | GBM22 | GBM31 | GBM40 |
|---|--|----------------|----------------|
| Performance characteristics | | | |
| Batch size lbs {g} | .882 {400} | .882 {400} | .882 {400} |
| Maximum throughput lbs/hr {kg/hr}* | 97 {44} | 111 {50} | 132 {60} |
| Bin capacity - large bins ft ³ {liter} | 0.4 {11.3} | 0.4 {11.3} | 0.4 {11.3} |
| Maximum number of materials | 4 | 4 | 4 |
| Number of standard dispensing valves† | 2 | 3 | 4 |
| Number of micro dispensing valves | 2 | 1 | 0 |
| Control software (# of components) | 4 or 12 | 4 or 12 | 4 or 12 |
| Dimensions inches {mm} | | | |
| A - Height above mounting plate | 27.25 {693} | 27.25 {693} | 27.25 {693} |
| B - Width | 21.75 {552.4} | 21.75 {552.4} | 21.75 {552.4} |
| C - Depth | 21.75 {552.4} | 21.75 {552.4} | 21.75 {552.4} |
| D - Controller height | 11.25 {285.75} | 11.25 {285.75} | 11.25 {285.75} |
| E - Controller width | 12.25 {311.15} | 12.25 {311.15} | 12.25 {311.15} |
| F - Controller depth | 8.19 {208.03} | 8.19 {208.03} | 8.19 {208.03} |
| Weight lbs {kg} | | | |
| Installed | 70 {32} | 70 {32} | 70 {32} |
| Shipping | 90 {41} | 90 {41} | 90 {41} |
| Voltage Running load amps | | | |
| 120V/1 phase 50/60 hz | 1.0 | 1.0 | 1.0 |
| 220V/1 phase 50/60 hz | 0.5 | 0.5 | 0.5 |
| Compressed air requirements | | | |
| | 40 psi @ 1 ft ³ /min { 2.8 bars @ 0.47 liters/sec} 1/4 in. NPT fitting | | |
| Material filling options | | | |
| Self-contained vacuum loader | ML8 or Z2HL | | |
| Central vacuum receiver | DL8 | | |
| Hand-fill | flat lid | | |

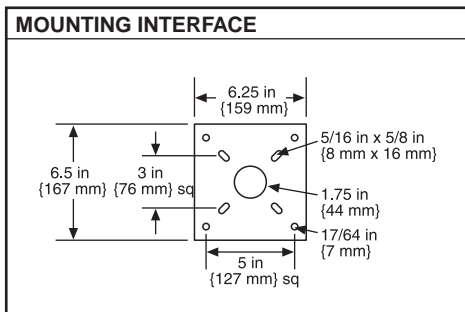

SPECIFICATION NOTES:

* Maximum throughput rates are based on using all dispense valves and dispensing no more than 1.0% colorant and/or additive per each micropulsing valve. Refer to the selection guide for more specific throughput information.

† The Regrind position features a 1.5-inch diameter valve to ensure flow of irregularly shaped material.

If you will be using this blender for central blending applications, it will be necessary to use a flow control valve with an air solenoid.



SPECIFICATIONS

GRAVIMETRIC BATCH BLENDERS
AutoWeigh GB100 Series Models

CONTROL

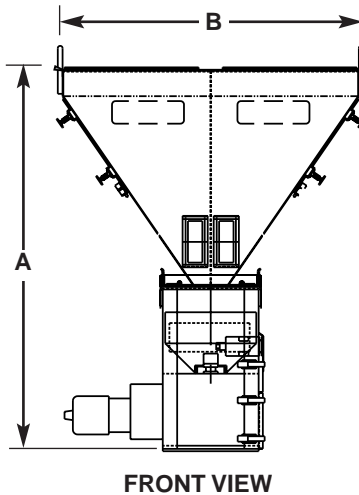
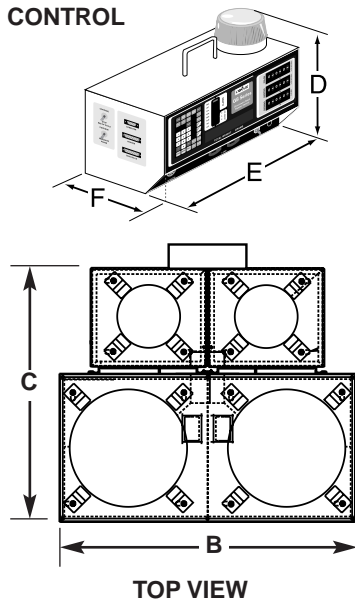

FRONT VIEW

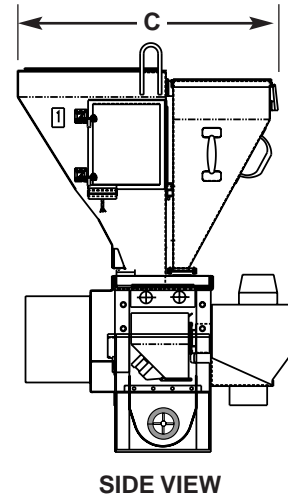

SIDE VIEW

| MODELS | GB122 | GB131 | GB140 |
|---|---|----------------|----------------|
| Performance characteristics | | | |
| Batch size lbs {g} | 2.2 {1000} | 2.2 {1000} | 2.2 {1000} |
| Maximum throughput lbs/hr {kg/hr}* | 200 {90} | 280 {128} | 450 {204} |
| Bin capacity - main ingredient ft ³ {liter} | 1.0 {28.32} | 1.0 {28.32} | 1.0 {28.32} |
| Bin capacity - minor ingredient ft ³ {liter} | 0.5 {14.16} | 0.5 {14.16} | 0.5 {14.16} |
| Maximum number of materials | 4 | 4 | 4 |
| Number of discharge valves | 2 | 3 | 4 |
| Number of micro pulsing valves | 2 | 1 | 0 |
| Control software (# of components) | 4 or 12 | 4 or 12 | 4 or 12 |
| Dimensions inches {mm} | | | |
| A - Height above mounting plate† | 38.9 {989.6} | 38.9 {989.6} | 38.9 {989.6} |
| B - Width | 33.2 {843.3} | 33.2 {843.3} | 33.2 {843.3} |
| C - Depth | 31.4 {797.6} | 31.4 {797.6} | 31.4 {797.6} |
| D - Controller height | 11.25 {285.75} | 11.25 {285.75} | 11.25 {285.75} |
| E - Controller width | 12.25 {311.15} | 12.25 {311.15} | 12.25 {311.15} |
| F - Controller depth | 8.19 {208.03} | 8.19 {208.03} | 8.19 {208.03} |
| Weight lbs {kg} | | | |
| Installed | 200 {90.7} | 200 {90.7} | 200 {90.7} |
| Shipping | 300 {136.1} | 300 {136.1} | 300 {136.1} |
| Voltage Total amps | | | |
| 120V/1 phase/50-60 hz | 2.0 | 2.0 | 2.0 |
| 240V/1 phase/50-60 hz | 1.0 | 1.0 | 1.0 |
| Compressed air requirements | | | |
| Discharge valves | 80 psi @ 0.2 ft ³ /min {5.5 bars @ 0.09 liters/sec}; 1/4 in. NPT fitting | | |
| Micro pulsing valves | 40 psi @ 0.2 ft ³ /min {2.8 bars @ 0.09 liters/sec}; 1/4 in. NPT fitting | | |

| MOUNTING INTERFACE | |
|--|--|
| IB04 | |
| SPECIFICATION NOTES: | |
| <p>Each stationary bin compartment can support a 12-inch loader or vacuum receiver. Removable bins can support a maximum of an 8-inch loader.</p> <p>* Throughput rates are based on bins with each micro-pulsing valve dispensing no more than 1% colorant and/or additive material and using a material with a bulk density of 35 lb/ft³.</p> <p>† The optional flow control valve adds 6.5 in. {165 mm} to total height.</p> | |



SPECIFICATIONS

**GRAVIMETRIC BATCH BLENDERS
GB 220 and 420 Models**

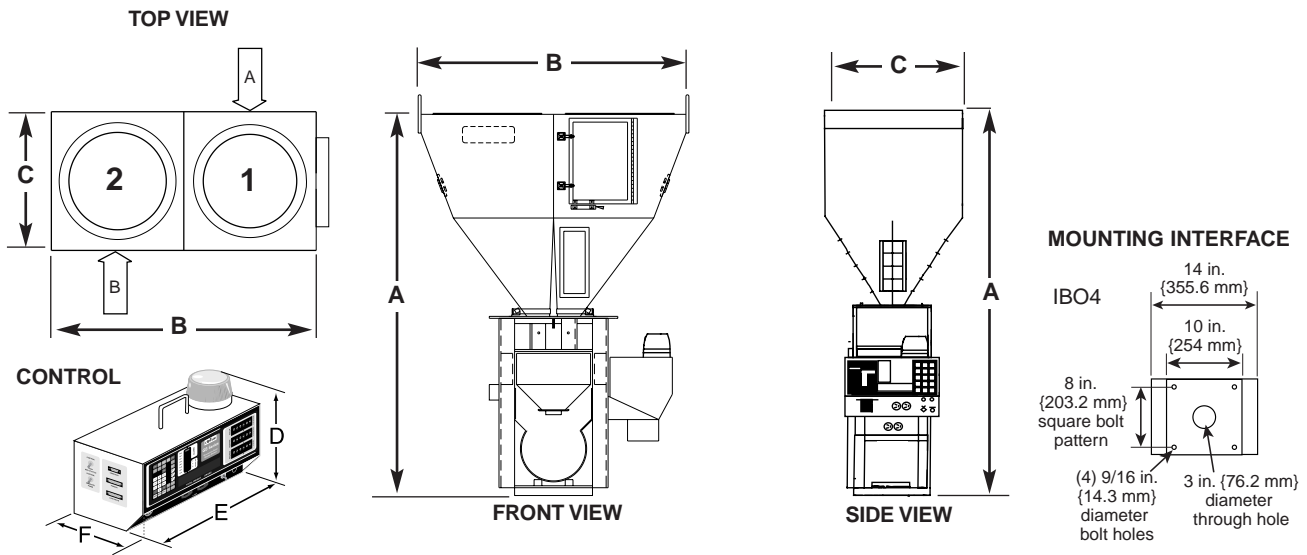

| MODELS | GB220 | GB221 | GB222 | GB420 | GB421 | GB422 |
|---|---|----------------|----------------|----------------|----------------|----------------|
| Performance characteristics | | | | | | |
| Batch size lbs {g} | 4.4 {2000} | 4.4 {2000} | 4.4 {2000} | 8.8 {4000} | 8.8 {4000} | 8.8 {4000} |
| Maximum throughput lbs/hr {kg/hr}* | 1239 {562} | 575 {261} | 540 {245} | 1966 {892} | 700 {318} | 680 {308} |
| Bin capacity - each ft ³ {liter} | 2.2 {62.3} | 2.2 {62.3} | 2.2 {62.3} | 2.2 {62.3} | 2.2 {62.3} | 2.2 {62.3} |
| Maximum number of materials | 2 | 3 | 4 | 2 | 3 | 4 |
| Number of discharge valves | 2 | 2 | 2 | 2 | 2 | 2 |
| Number of additive feeders | 0 | 1 | 2 | 0 | 1 | 2 |
| Control software (# of components) | 4 or 12 | 4 or 12 | 4 or 12 | 4 or 12 | 4 or 12 | 4 or 12 |
| Dimensions inches {mm} | | | | | | |
| A - Height above mounting plate† | 48 {1217.9} | 48 {1217.9} | 48 {1217.9} | 54 {1370.3} | 54 {1370.3} | 54 {1370.3} |
| B - Width ‡ | 34 {863.6} | 34 {863.6} | 34 {863.6} | 34 {863.6} | 34 {863.6} | 34 {863.6} |
| C - Depth‡ | 17.5 {444.5} | 17.5 {444.5} | 17.5 {444.5} | 17.5 {444.5} | 17.5 {444.5} | 17.5 {444.5} |
| D - Controller height | 11.25 {285.75} | 11.25 {285.75} | 11.25 {285.75} | 11.25 {285.75} | 11.25 {285.75} | 11.25 {285.75} |
| E - Controller width | 12.25 {311.15} | 12.25 {311.15} | 12.25 {311.15} | 12.25 {311.15} | 12.25 {311.15} | 12.25 {311.15} |
| F - Controller depth | 8.19 {208.03} | 8.19 {208.03} | 8.19 {208.03} | 8.19 {208.03} | 8.19 {208.03} | 8.19 {208.03} |
| Weight lbs {kg} | | | | | | |
| Installed | 220 {100} | 260 {118} | 300 {136} | 245 {111} | 285 {129} | 325 {147} |
| Shipping | 325 {147} | 265 {120} | 405 {183} | 350 {159} | 390 {177} | 430 {195} |
| Voltage Total amps | | | | | | |
| 120V/1 phase/50-60 Hz | 4.8 | 5.8 | 6.8 | 4.8 | 5.8 | 6.8 |
| 240V/1 phase/50-60 Hz | 2.5 | 3.0 | 3.5 | 2.5 | 3.0 | 3.5 |
| Compressed air requirements | | | | | | |
| Discharge valves | 80 psi @ 0.2 ft ³ /min. {5.5 bars @0.09 liters/sec}, 1/4 in. NPT fitting | | | | | |
| Compressed air feeder | 40 psi @ 2 ft ³ /min. {2.8 bars @0.94 liters/sec}, 1/4 in. NPT fitting | | | | | |

SPECIFICATION NOTES:

Each bin compartment will support a 12-inch to 15-inch loader or vacuum receiver.

* Throughput rates are based on using no more than 5% additive or colorant material total in either the CAF3 compressed air or F03 auger feeder. Always refer to the selection guide for specific throughput information.

† The optional flow control valve adds 6.5 in. {165 mm} to the total height. We recommend using the flow control valve when mounting the blender to a stand, surge bin or hopper.

‡ Feeders will increase width and depth dimensions. Please refer to feeder specifications.

SPECIFICATIONS

**GRAVIMETRIC BATCH BLENDERS
AutoWeigh GB240 and GB440 Models**

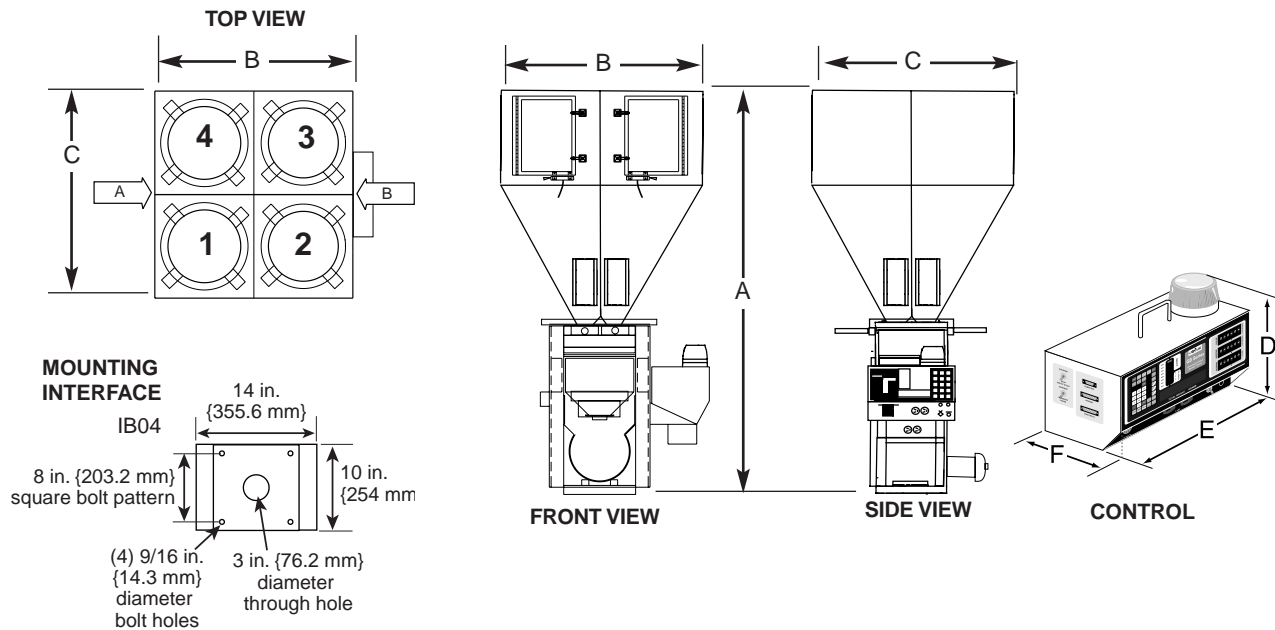

| MODELS | GB240 | GB241 | GB242 | GB440 | GB441 | GB442 |
|---|---|----------------|----------------|----------------|----------------|----------------|
| Performance characteristics | | | | | | |
| Batch size lbs {g} | 4.4 {2000} | 4.4 {2000} | 4.4 {2000} | 8.8 {4000} | 8.8 {4000} | 8.8 {4000} |
| Maximum throughput lbs/hr {kg/hr}* | 993 {451} | 678 {308} | 518 {235} | 1645 {748} | 983 {446} | 704 {319} |
| Bin capacity - main ingredient ft ³ {liter} | 3.5 {99.12} | 3.5 {99.12} | 3.5 {99.12} | 3.5 {99.12} | 3.5 {99.12} | 3.5 {99.12} |
| Bin capacity - minor ingredient ft ³ {liter} | NA | 0.5 {14.16} | 0.5 {14.16} | NA | 0.5 {14.16} | 0.5 {14.16} |
| Maximum number of materials | 4 | 5 | 6 | 4 | 5 | 6 |
| Number of discharge valves | 4 | 4 | 4 | 4 | 4 | 4 |
| Number of additive feeders | 0 | 1 | 2 | 0 | 1 | 2 |
| Control software (# of components) | 4 or 12 | 12 | 12 | 4 or 12 | 12 | 12 |
| Dimensions inches {mm} | | | | | | |
| A - Height above mounting plate† | 59.75 {1517.5} | 59.75 {1517.5} | 59.75 {1517.5} | 65.75 {1669.9} | 65.75 {1669.9} | 65.75 {1669.9} |
| B - Width ‡ | 34 {863.6} | 34 {863.6} | 34 {863.6} | 34 {863.6} | 34 {863.6} | 34 {863.6} |
| C - Depth‡ | 34 {863.6} | 34 {863.6} | 34 {863.6} | 34 {863.6} | 34 {863.6} | 34 {863.6} |
| D - Controller height | 11.25 {285.75} | 11.25 {285.75} | 11.25 {285.75} | 11.25 {285.75} | 11.25 {285.75} | 11.25 {285.75} |
| E - Controller width | 12.25 {311.15} | 12.25 {311.15} | 12.25 {311.15} | 12.25 {311.15} | 12.25 {311.15} | 12.25 {311.15} |
| F - Controller depth | 8.19 {208.03} | 8.19 {208.03} | 8.19 {208.03} | 8.19 {208.03} | 8.19 {208.03} | 8.19 {208.03} |
| Weight lbs {kg} | | | | | | |
| Installed | 230 {104} | 270 {122} | 310 {140} | 255 {116} | 295 {134} | 335 {152} |
| Shipping | 335 {152} | 375 {170} | 415 {188} | 360 {163} | 400 {181} | 440 {200} |
| Voltage Total amps | | | | | | |
| 120V/1 phase/50-60 Hz | 4.8 | 5.8 | 6.8 | 4.8 | 5.8 | 6.8 |
| 240V/1 phase/50-60 Hz | 2.5 | 3.0 | 3.5 | 2.5 | 3.0 | 3.5 |
| Compressed air requirements | | | | | | |
| Discharge valves | 80 psi @ 0.2 ft ³ /min. {5.5bars @ 0.09 liters/sec}, 1/4 in. NPT fitting | | | | | |
| Compressed air feeder | 40 psi @ 2 ft ³ /min. {2.8bars @ 0.94 liters/sec}, 1/4 in. NPT fitting | | | | | |

SPECIFICATION NOTES:
 Each bin compartment can support a 12-inch to 15-inch loader or vacuum receiver.
 * Throughput rates are based on using no more than 2% additive or colorant material total in either the CAF3 compressed air or F03 auger feeder. Always refer to the selection guide for specific throughput information.
 † The optional flow control valve adds 6.5 in. {165 mm} to the total height. We recommend using the flow control valve when mounting the blender to a stand, surge bin or hopper.
 ‡ Feeders will increase width and depth dimensions. Please refer to feeder specifications.



SPECIFICATIONS

GRAVIMETRIC BATCH BLENDERS
AutoWeigh GB900 Series Models

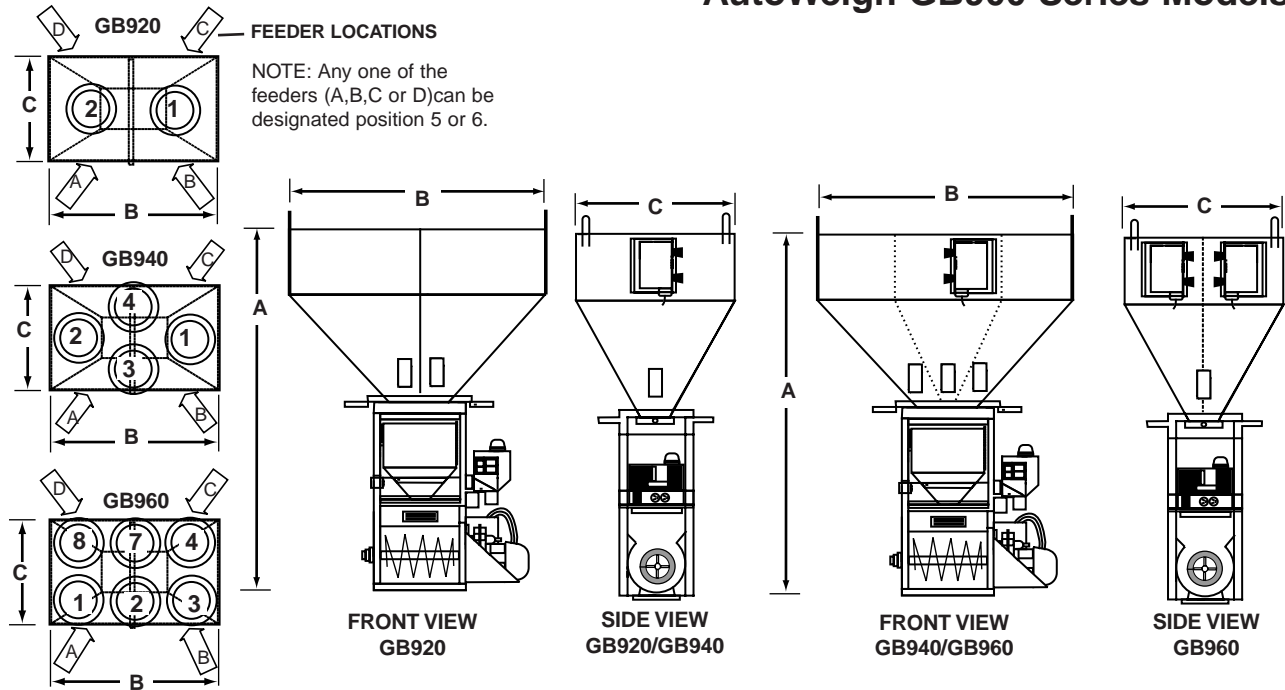

| MODELS | GB920 | GB940 | GB960 |
|---|---|----------------|----------------|
| Performance characteristics | | | |
| Batch size lbs {g} | 19.8 {9000} | 19.8 {9000} | 19.8 {9000} |
| Maximum throughput lbs/hr {kg/hr}* | 5200 {2359} | 3300 {1497} | 2124 {965} |
| Bin capacity - main ingredient ft ³ {liter} | 8.5 {240.7} | 6.7 {189.7} | 3.6 {102.9} |
| Bin capacity - minor ingredient ft ³ {liter} | NA | 3.6 {107.6} | 3.6 {107.6} |
| Maximum number of materials | 6 | 8 | 10 |
| Number of discharge valves | 2 | 4 | 6 |
| Number of additive feeders | up to 4 | up to 4 | up to 4 |
| Control software (# of components) | 4 or 12 | 4 or 12 | 12 |
| Dimensions inches {mm} | | | |
| A - Height above mounting plate† | 74 {1880.7} | 74 {1880.7} | 74 {1880.7} |
| B - Width‡ | 56 {1421.4} | 56 {1421.4} | 56 {1421.4} |
| C - Depth‡ | 34 {863.6} | 34 {863.6} | 34 {863.6} |
| D - Controller height | 11.25 {285.75} | 11.25 {285.75} | 11.25 {285.75} |
| E - Controller width | 12.25 {311.15} | 12.25 {311.15} | 12.25 {311.15} |
| F - Controller depth | 8.19 {208.03} | 8.19 {208.03} | 8.19 {208.03} |
| Weight lbs {kg} | | | |
| Installed | 480 {218} | 480 {218} | 480 {218} |
| Shipping | 600 {272.2} | 600 {272.2} | 600 {272.2} |
| Voltage Running load amps§ | | | |
| 120V/1 phase/60 hz (control and mixer) | 8.5 | 8.5 | 8.5 |
| 220V/1 phase/60 hz (control and mixer) | 4.25 | 4.25 | 4.25 |
| 220V/1 phase/50 hz (control) | 0.15 | 0.15 | 0.15 |
| 220V/3 phase/50 hz (mixer) | 2.2 | 2.2 | 2.2 |
| 400V/3 phase/50 hz (mixer) | 1.1 | 1.1 | 1.1 |
| Compressed air requirements | | | |
| Discharge valves | 80 psi @ 0.2 ft ³ /min {5.5 bars @ 0.09 liters/sec}; 1/4 in. NPT fitting | | |
| Compressed air feeder | 40 psi @ 2.0 ft ³ /min {2.8 bars @ 0.94 liters/sec}; 1/4 in. NPT fitting | | |
| Maximum loader sizes** | | | |
| Number of 20 inch loaders | 2 | 2 | 3 |
| Number of 15 inch loaders | 2 | 4 | 6 |

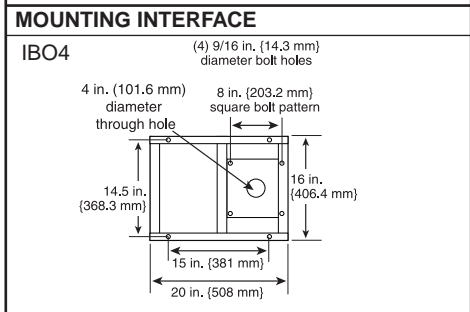
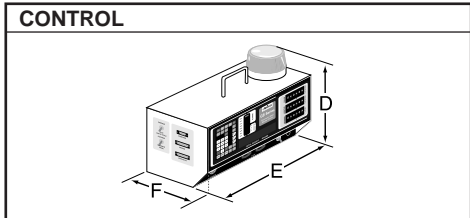

SPECIFICATION NOTES:

* Maximum throughput rates are based on 35 lbft³ pelletized material and using all dispense valves. Use of feeders for minor ingredients will reduce this rate. Refer to the selection guide for more specific throughput information.

† The optional flow control valve will add 6.5 in. {165 mm} to the total height. We recommend using the flow control valve when mounting the blender to a stand, surge bin or hopper.

‡ Feeders will increase depth dimensions. Please refer to feeder specification.

§ Each auger feeder requires an additional 1 amp @ 120V or 0.5 amp @ 240V.

** Maximum loader sizes may be used only when the loader is adjacent to loaders of a smaller diameter.



SPECIFICATIONS

GRAVIMETRIC BATCH BLENDERS
AutoWeigh GB1840 and 1860 Models

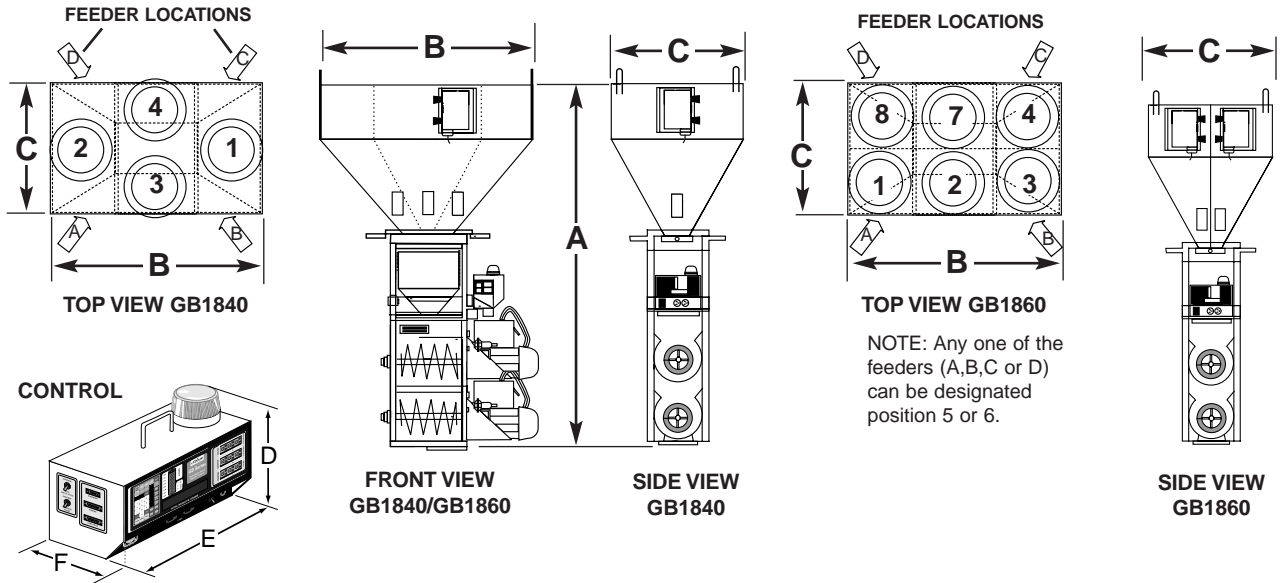

| MODELS | GB1840 | GB1860 |
|--|---|----------------|
| Performance characteristics | | |
| Batch size lbs {g} | 39.7 {18000} | 39.7 {18000} |
| Maximum throughput lbs/hr {kg/hr}* | 4114 {1870} | 2566 {1166} |
| Bin Capacity - Main Ingredient ft ³ {liter} | 6.7 {189.7} | 3.8 {107.6} |
| Bin Capacity - Minor Capacity ft ³ {liter} | 3.8 {107.6} | 3.8 {107.6} |
| Maximum number of materials | 8 | 10 |
| Number of discharge valves | 4 | 6 |
| Number of additive feeders | up to 4 | up to 4 |
| Control software (# of components) | 4 or 12 | 12 |
| Dimensions inches {mm} | | |
| A - Height above mounting plate | 93 {2362.2} | 93 {2362.2} |
| B - Width† | 56 {1421.4} | 56 {1421.4} |
| C - Depth† | 34 {863.6} | 34 {863.6} |
| D - Controller height | 11.25 {285.75} | 11.25 {285.75} |
| E - Controller width | 12.25 {311.15} | 12.25 {311.15} |
| F - Controller depth | 8.19 {208.03} | 8.19 {208.03} |
| Weight lbs {kg} | | |
| Installed | 730 {331} | 730 {331} |
| Shipping | 850 {385.5} | 850 {385.5} |
| Voltage Running load amps‡ | | |
| 110V/1 phase/60hz (control) | 0.3 | 0.3 |
| 220V/1 phase/60hz (mixer) | 8.2 | 8.2 |
| 220V/1 phase/60hz (control) | 0.2 | 0.2 |
| 220V/1 phase/60hz (mixer) | 8.2 | 8.2 |
| 220V/1 phase/50hz (control) | 0.2 | 0.2 |
| 220V/3 phase/50hz (mixer) | 4.4 | 4.4 |
| 400V/3 phase/50hz (mixer) | 2.2 | 2.2 |
| Compressed air requirements | | |
| Discharge valves | 80 psi @ 0.2 ft ³ /min {5.5 bars @ 0.09 liters/sec} 1/4 in. NPT fitting | |
| Maximum loader sizes § | | |
| Number of 20 inch loaders | 2 | 3 |
| Number of 15 inch loaders | 4 | 6 |

MOUNTING INTERFACE

The diagram shows a rectangular mounting plate with a 15 in. {381 mm} width and a 16 in. {406.4 mm} height. It features a 4 in. {101.6 mm} diameter through hole and four 9/16 in. {14.3 mm} diameter bolt holes arranged in an 8 in. {203.2 mm} square pattern. The overall width is 20 in. {508 mm} and the overall height is 14.5 in. {368.3 mm}. The bolt holes are labeled 'IB04'.

SPECIFICATION NOTES

- * Maximum throughput rates are based on 35 lb/ft³ pelletized material and using all dispense valves. Use of feeders for minor ingredients will reduce this rate. Refer to the selection guide for more specific throughput information.
- † Feeders will increase width dimensions. Please refer to feeder specification.
- ‡ Each auger feeder requires an additional 1 amp @ 120V or 0.5 amp @ 240V.
- § Maximum loader sizes may be used only when the loader is adjacent to loaders of a smaller diameter.



SPECIFICATIONS

**GRAVIMETRIC BATCH BLENDERS
WSBM Series models**

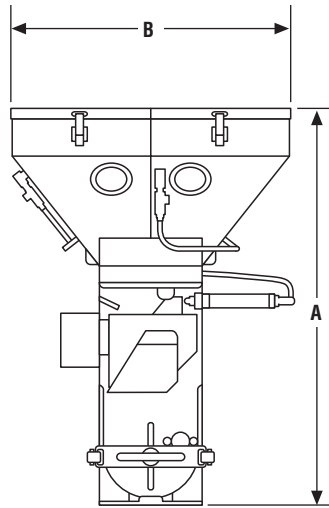

**IB06 Loader Mounting Interface
6.5in (165 mm)**

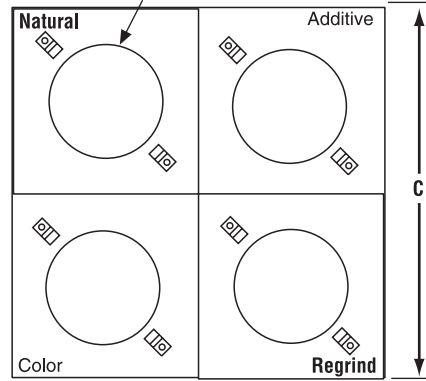

CONTROL (REMOTE MOUNTED)

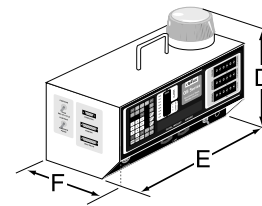

| MODELS | WSBM22 | WSBM131 | WSBM140 |
|--|--|----------------|----------------|
| Performance characteristics | | | |
| Batch size lbs {g} | 0.882 {400} | 0.882 {400} | 0.882 {400} |
| Maximum throughput lbs/hr {kg/hr}* | 97 {44} | 111 {50} | 132 {60} |
| Bin capacity - standard bins ft ³ {liter} | 0.4 {5.7} | 0.4 {5.7} | 0.4 {5.7} |
| Maximum number of materials | 4 | 4 | 4 |
| Number of standard dispensing valves | 2 | 3 | 4 |
| Number of micro dispensing valves | 2 | 1 | 0 |
| Control software (# of components) | 4 or 12 | 4 or 12 | 4 or 12 |
| Dimensions inches {mm} | | | |
| A - Height above mounting plate | 27.25 {693} | 27.25 {693} | 27.25 {693} |
| B - Width | 21.75 {552.4} | 21.75 {552.4} | 21.75 {552.4} |
| C - Depth | 21.75 {552.4} | 21.75 {552.4} | 21.75 {552.4} |
| D - Controller height | 11.25 {285.75} | 11.25 {285.75} | 11.25 {285.75} |
| E - Controller width | 12.25 {311.15} | 12.25 {311.15} | 12.25 {311.15} |
| F - Controller depth | 8.19 {208.03} | 8.19 {208.03} | 8.19 {208.03} |
| Weight lbs {kg} | | | |
| Installed | 60 {27} | 60 {27} | 60 {27} |
| Shipping | 80 {36.3} | 80 {36.3} | 80 {36.3} |
| Voltage Running load amps | | | |
| 120V/1 phase 50/60 hz | 1.0 | 1.0 | 1.0 |
| 220V/1 phase 50/60 hz | 0.5 | 0.5 | 0.5 |
| Compressed air requirements | | | |
| | 40 psi @ 1 ft ³ /min { bars @ 0.47 liters/sec} 1/4 in. NPT fitting | | |
| Material filling options | | | |
| Self-contained vacuum loader | ML8 | | |
| Central vacuum receiver | DL8 | | |
| Hand-fill | flat lid | | |

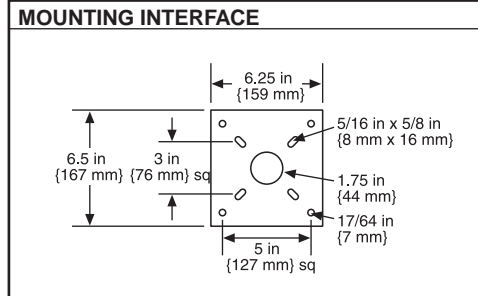

SPECIFICATION NOTES:

* Maximum throughput rates are based on using all dispense valves dispensing no more than 1.0% colorant or additive per each micropulsing valve. Refer to the selection guide for more specific throughput information.

APPLICATION NOTE:

Handfill unless otherwise specified.

If you will be using this blender for central blending applications, it will be necessary to use a flow control valve with an air solenoid.



SPECIFICATIONS

**GRAVIMETRIC BATCH BLENDERS
WSB 100 and 100R Models**

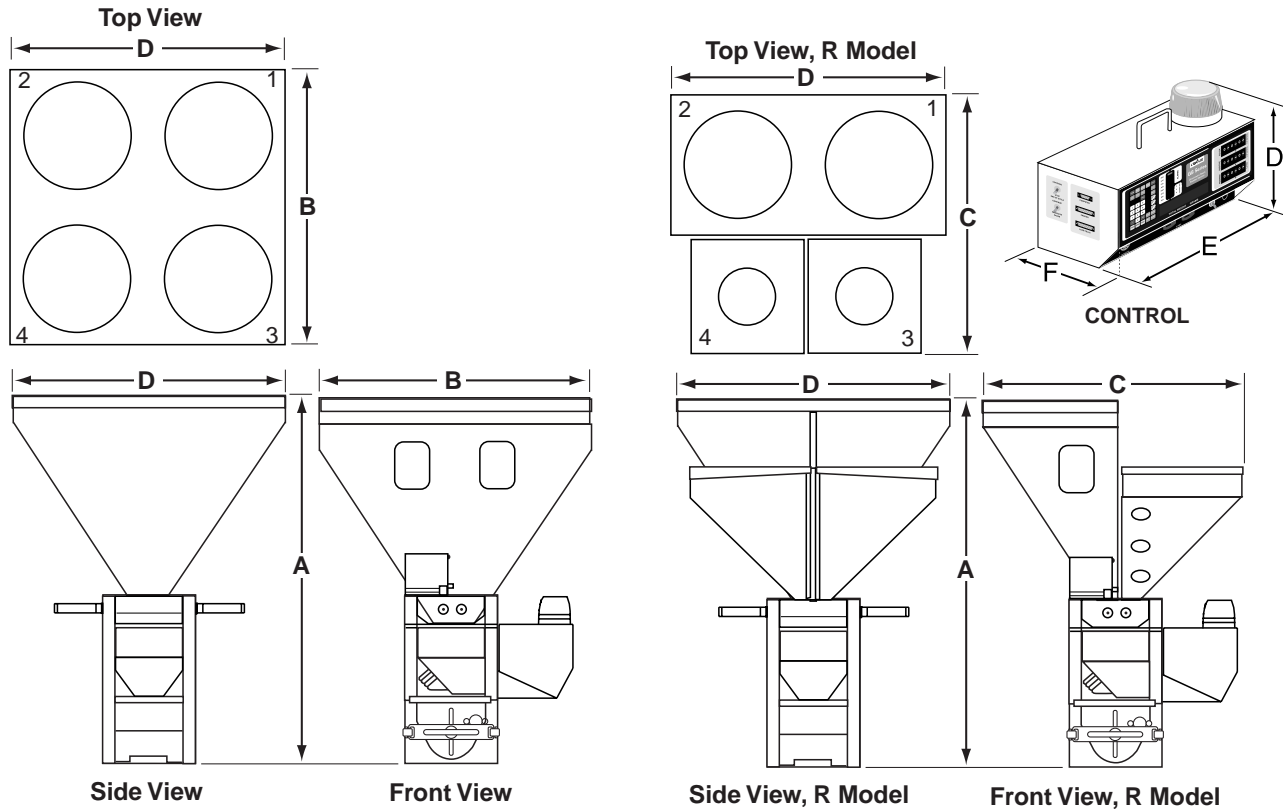

| MODELS | WSB122 | WSB131 | WSB140 |
|---|--|----------------|----------------|
| Performance characteristics | | | |
| Batch size lbs {g} | 2.2 {1000} | 2.2 {1000} | 2.2 {1000} |
| Maximum throughput lbs/hr {kg/hr}* | 200 {91} | 280 {128} | 450 {204} |
| Bin capacity - main ingredient ft ³ {liter} | 1.0 {28.3} | 1.0 {28.3} | 1.0 {28.3} |
| Bin capacity - minor ingredient ft ³ {liter} | 1.0 {28.3} | 1.0 {28.3} | 1.0 {28.3} |
| Maximum number of materials | 4 | 4 | 4 |
| Number of discharge valves | 2 | 3 | 4 |
| Number of micro pulsing valves | 2 | 1 | 0 |
| Control software (# of components) | 4 or 12 | 4 or 12 | 4 or 12 |
| Dimensions inches {mm} | | | |
| A - Height above mounting plate† | 38.9 {989.6} | 38.9 {989.6} | 38.9 {989.6} |
| B - Width | 33.2 {843.3} | 33.2 {843.3} | 33.2 {843.3} |
| C - Width R (removable bins) | 30.2 {766.3} | 30.2 {766.3} | 30.2 {766.3} |
| D - Depth | 31.4 {797.6} | 31.4 {797.6} | 31.4 {797.6} |
| E - Controller height | 11.25 {285.75} | 11.25 {285.75} | 11.25 {285.75} |
| F - Controller width | 12.25 {311.15} | 12.25 {311.15} | 12.25 {311.15} |
| G - Controller depth | 8.19 {208.03} | 8.19 {208.03} | 8.19 {208.03} |
| Weight lbs {kg} | | | |
| Installed | 200 {90.7} | 200 {90.7} | 200 {90.7} |
| Shipping | 300 {136.1} | 300 {136.1} | 300 {136.1} |
| Voltage Total amps | | | |
| 120V/1 phase/50-60 hz | 2.0 | 2.0 | 2.0 |
| 240V/1 phase/50-60 hz | 1.0 | 1.0 | 1.0 |
| Compressed air requirements | | | |
| Discharge valves | 60 psi @ 0.2 ft ³ /min { 4.1 bars @ 0.09 liters/sec}; 1/4 in. NPT fitting | | |
| Micro pulsing valves | 60 psi @ 0.2 ft ³ /min { 4.1 bars @ 0.09 liters/sec}; 1/4 in. NPT fitting | | |

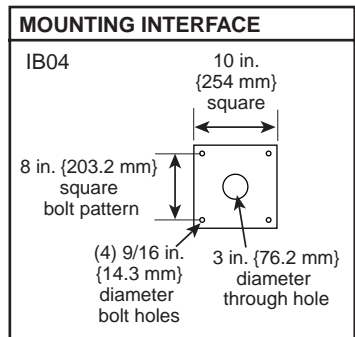

SPECIFICATION NOTES:

R model has removable bins with vertical valves. Removable bins can support an 8-inch loader or vacuum receiver. Stationary bins can support a 12-inch loader or vacuum receiver. Maximum throughput for a 140R model is 437 lb/hr {198.2 kg/hr}. Minor ingredient bin capacity is 0.7 ft³ {19.8 liter}.

* Throughput rates are based on bins with each micropulsing valve dispensing no more than 1% colorant and/or additive material.

† The optional flow control valve adds 3.5 in. {88.9 mm} to total height.

SPECIFICATIONS

**GRAVIMETRIC BATCH BLENDERS
WSB 220 and 420 Models**

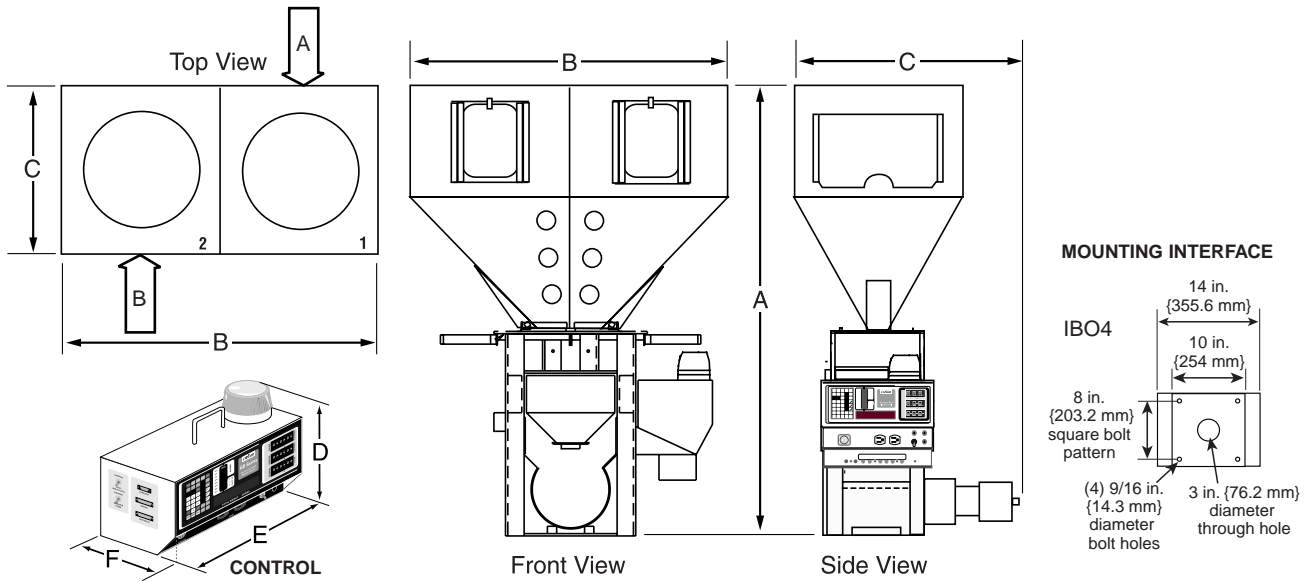

| MODELS | WSB220 | WSB221 | WSB222 | WSB420 | WSB421 | WSB422 |
|---|---|----------------|----------------|----------------|----------------|----------------|
| Performance characteristics | | | | | | |
| Batch size lbs {g} | 4.4 {2000} | 4.4 {2000} | 4.4 {2000} | 8.8 {4000} | 8.8 {4000} | 8.8 {4000} |
| Maximum throughput lbs/hr {kg/hr}* | 1239 {562} | 575 {261} | 540 {245} | 1966 {892} | 700 {318} | 680 {308} |
| Bin capacity - each ft ³ {liter} | 2.0 {56.6} | 2.0 {56.6} | 2.0 {56.6} | 2.0 {56.6} | 2.0 {56.6} | 2.0 {56.6} |
| Maximum number of materials | 2 | 3 | 4 | 2 | 3 | 4 |
| Number of discharge valves | 2 | 2 | 2 | 2 | 2 | 2 |
| Number of additive feeders | 0 | 1 | 2 | 0 | 1 | 2 |
| Control software (# of components) | 4 or 12 | 4 or 12 | 4 or 12 | 4 or 12 | 4 or 12 | 4 or 12 |
| Dimensions inches (mm) | | | | | | |
| A - Height above mounting plate† | 48 {1217.9} | 48 {1217.9} | 48 {1217.9} | 54 {1370.3} | 54 {1370.3} | 54 {1370.3} |
| B - Width ‡ | 34.4 {873.8} | 34.4 {873.8} | 34.4 {873.8} | 34.4 {873.8} | 34.4 {873.8} | 34.4 {873.8} |
| C - Depth‡ | 24.75 {628.6} | 24.75 {628.6} | 24.75 {628.6} | 24.4 {619.8} | 24.4 {619.8} | 24.4 {619.8} |
| D - Controller height | 11.25 {285.75} | 11.25 {285.75} | 11.25 {285.75} | 11.25 {285.75} | 11.25 {285.75} | 11.25 {285.75} |
| E - Controller width | 12.25 {311.15} | 12.25 {311.15} | 12.25 {311.15} | 12.25 {311.15} | 12.25 {311.15} | 12.25 {311.15} |
| F - Controller depth | 8.19 {208.03} | 8.19 {208.03} | 8.19 {208.03} | 8.19 {208.03} | 8.19 {208.03} | 8.19 {208.03} |
| Weight lbs (kg) | | | | | | |
| Installed | 220 {100} | 260 {118} | 300 {136} | 245 {111} | 285 {129} | 325 {147} |
| Shipping | 325 {147} | 265 {120} | 405 {183} | 350 {159} | 390 {177} | 430 {195} |
| Voltage Total amps§ | | | | | | |
| 120V/1 phase/50-60 Hz | 4.8 | 4.8 | 4.8 | 4.8 | 4.8 | 4.8 |
| 240V/1 phase/50-60 Hz | 2.5 | 2.5 | 2.5 | 2.5 | 2.5 | 2.5 |
| Compressed air requirements | | | | | | |
| Discharge valves | 80 psi @ 0.2 ft ³ /min. {5.5 bars @0.09 liters/sec}, 1/4 in. NPT fitting | | | | | |
| Compressed air feeder | 40 psi @ 2 ft ³ /min. {2.8 bars @0.94 liters/sec}, 1/4 in. NPT fitting | | | | | |

SPECIFICATION NOTES:

Each bin compartment will support a 12-inch to 15-inch loader or vacuum receiver.

* Throughput rates are based on using no more than 5% additive or colorant material total in either the CAF3 compressed air or F03 auger feeder. Always refer to the selection guide for specific throughput information.

† The optional butterfly control flow control valve adds 3.5 in. {88.9 mm} to the total height. We recommend using the flow control valve when mounting the blender to a stand, surge bin or hopper.

‡ Feeders will increase width and depth dimensions. Please refer to feeder specifications.

§ Each additional auger feeder requires an additional 1 amp @ 120V or 0.5 amps @ 240V.

SPECIFICATIONS

**GRAVIMETRIC BATCH BLENDERS
WSB 240/440 and 240/440R Models**

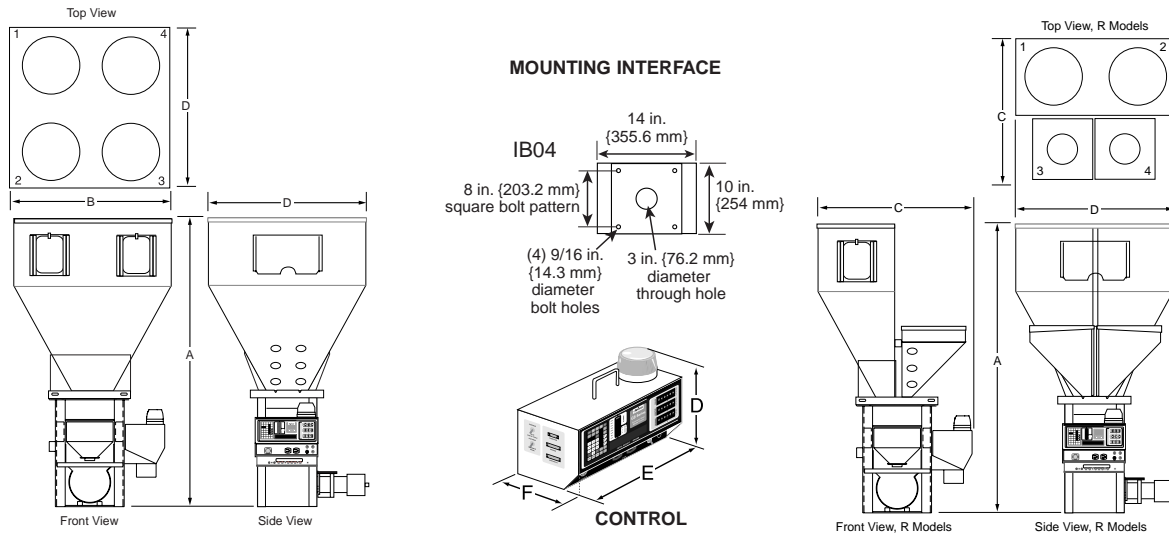

| MODELS | WSB240 | WSB241 | WSB242 | WSB440 | WSB441 | WSB442 |
|---|---|----------------|----------------|----------------|----------------|----------------|
| Performance characteristics | | | | | | |
| Batch size lbs {g} | 4.4 {2000} | 4.4 {2000} | 4.4 {2000} | 8.8 {4000} | 8.8 {4000} | 8.8 {4000} |
| Maximum throughput lbs/hr {kg/hr}* | 993 {451} | 678 {308} | 518 {235} | 1645 {748} | 983{446} | 704 {319} |
| Bin capacity - main ingredient ft ³ {liter} | 3.5 {99.12} | 3.5 {99.12} | 3.5 {99.12} | 3.5 {99.12} | 3.5 {99.12} | 3.5 {99.12} |
| Bin capacity - minor ingredient ft ³ {liter} | NA | 0.5 {14.16} | 0.5 {14.16} | NA | 0.5 {14.16} | 0.5 {14.16} |
| Maximum number of materials | 4 | 5 | 6 | 4 | 5 | 6 |
| Number of discharge valves | 4 | 4 | 4 | 4 | 4 | 4 |
| Number of additive feeders | 0 | 1 | 2 | 0 | 1 | 2 |
| Control software (# of components) | 4 or 12 | 12 | 12 | 4 or 12 | 12 | 12 |
| Dimensions inches {mm} | | | | | | |
| A - Height above mounting plate† | 59.75 {1517.5} | 59.75 {1517.5} | 59.75 {1517.5} | 65.75 {1669.9} | 65.75 {1669.9} | 65.75 {1669.9} |
| B - Width ‡ | 34.4 {873.8} | 34.4 {873.8} | 34.4 {873.8} | 34.4 {873.8} | 34.4 {873.8} | 34.4 {873.8} |
| C - Width R (removable bins)‡ | 32.2 {817.9} | 32.2 {817.9} | 32.2 {817.9} | 32.2 {817.9} | 32.2 {817.9} | 32.2 {817.9} |
| D - Depth‡ | 34.4 {873.8} | 34.4 {873.8} | 34.4 {873.8} | 34.4 {873.8} | 34.4 {873.8} | 34.4 {873.8} |
| E - Controller height | 11.25 {285.75} | 11.25 {285.75} | 11.25 {285.75} | 11.25 {285.75} | 11.25 {285.75} | 11.25 {285.75} |
| F - Controller width | 12.25 {311.15} | 12.25 {311.15} | 12.25 {311.15} | 12.25 {311.15} | 12.25 {311.15} | 12.25 {311.15} |
| G - Controller depth | 8.19 {208.03} | 8.19 {208.03} | 8.19 {208.03} | 8.19 {208.03} | 8.19 {208.03} | 8.19 {208.03} |
| Weight lbs {kg} | | | | | | |
| Installed | 230 {104} | 270 {122} | 310 {140} | 255 {116} | 295 {134} | 335 {152} |
| Shipping | 335 {152} | 375 {170} | 415 {188} | 360 {163} | 400 {181} | 440 {200} |
| Voltage Total amps § | | | | | | |
| 120V/1 phase/50-60 Hz | 4.8 | 4.8 | 4.8 | 4.8 | 4.8 | 4.8 |
| 240V/1 phase/50-60 Hz | 2.5 | 2.5 | 2.5 | 2.5 | 2.5 | 2.5 |
| Compressed air requirements | | | | | | |
| Discharge valves | 80 psi @ 0.2 ft ³ /min. {5.5bars @ 0.09 liters/sec}, 1/4 in. NPT fitting | | | | | |
| Compressed air feeder | 40 psi @ 2 ft ³ /min. {2.8bars @ 0.94 liters/sec}, 1/4 in. NPT fitting | | | | | |

SPECIFICATION NOTES:

R models have removable bins. The removable bins can support 8-inch loaders. Stationary bin compartments can support 12-inch to 15-inch loaders.

* Throughput rates are based on using the F03 auger feeder dispensing no more than 2% per additive or colorant. Maximum throughput rates for R models are: WSB240R with no feeders 864 lb/hr; with one feeder 619 lb/hr; with two feeders 483 lb/hr. For WSB440R model with no feeder 1326 lb/hr; with one feeder, 864 lb/hr; with two feeders 640 lb/hr.

† The optional butterfly flow control valve adds 3.5 in. {88.9 mm} to the total height. We recommend using the flow control valve when mounting the blender to a stand, surge bin or hopper.

‡ Feeders will increase width and depth dimensions. Please refer to feeder specifications.

§ Each auger feeder requires an additional 1 amp @ 120V or 0.5 amp @ 240V.



SPECIFICATIONS

**GRAVIMETRIC BATCH BLENDERS
WSB 920, 940, 950 and 960 Models**

NOTE: Loader configuration is the same for all models.

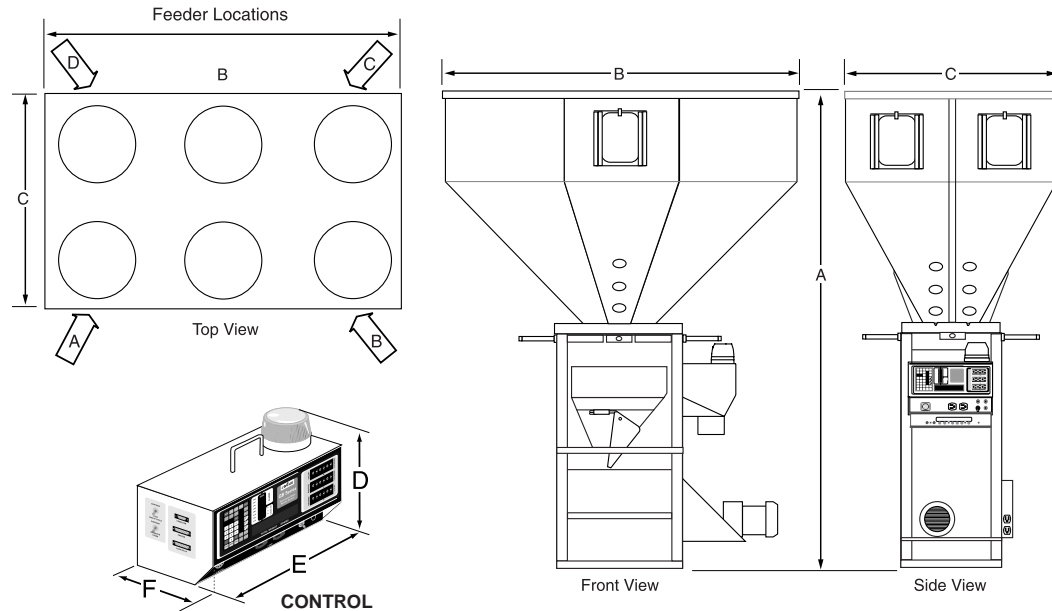

| MODELS | WSB920 | WSB940 | WSB950 | WSB960 |
|---|---|----------------|----------------|----------------|
| Performance characteristics | | | | |
| Batch size lbs {g} | 19.8 {9000} | 19.8 {9000} | 19.8 {9000} | 19.8 {9000} |
| Maximum throughput lbs/hr {kg/hr}* | 5200 {2359} | 3300 {1487} | 2492 {1132} | 2124 {965} |
| Bin capacity - main ingredient ft ³ {liter} | 6.7 {189.7} | 6.7 {189.7} | 6.7 {189.7} | NA |
| Bin capacity - minor ingredient ft ³ {liter} | NA | 3.8 {107.6} | 3.8 {107.6} | 3.8 {107.6} |
| Maximum number of materials | 6 | 8 | 9 | 10 |
| Number of discharge valves | 2 | 4 | 5 | 6 |
| Number of additive feeders | up to 4 | up to 4 | up to 4 | up to 4 |
| Control software (# of components) | 4 or 12 | 4 or 12 | 12 | 12 |
| Dimensions inches {mm} | | | | |
| A - Height above mounting plate | 74 {1880.7} | 74 {1880.7} | 74 {1880.7} | 74 {1880.7} |
| B - Width† | 56 {1421.4} | 56 {1421.4} | 56 {1421.4} | 56 {1421.4} |
| C - Depth† | 34.4 {875.3} | 34.4 {875.3} | 34.4 {875.3} | 34.4 {875.3} |
| D - Controller height | 11.25 {285.75} | 11.25 {285.75} | 11.25 {285.75} | 11.25 {285.75} |
| E - Controller width | 12.25 {311.15} | 12.25 {311.15} | 12.25 {311.15} | 12.25 {311.15} |
| F - Controller depth | 8.19 {208.03} | 8.19 {208.03} | 8.19 {208.03} | 8.19 {208.03} |
| Weight lbs {kg} | | | | |
| Installed | 480 {218} | 480 {218} | 480 {218} | 480 {218} |
| Shipping | 600 {272.2} | 600 {272.2} | 600 {272.2} | 600 {272.2} |
| Voltage Running load amps ‡ | | | | |
| 120V/1 phase/60 hz (control and mixer) | 8.5 | 8.5 | 8.5 | 8.5 |
| 220V/1 phase/60 hz (control and mixer) | 4.3 | 4.3 | 4.3 | 4.3 |
| 220V/1 phase/50 hz (control) | 0.15 | 0.15 | 0.15 | 0.15 |
| 220V/3 phase/50 hz (mixer) | 2.2 | 2.2 | 2.2 | 2.2 |
| 400V/3 phase/50 hz (mixer) | 1.1 | 1.1 | 1.1 | 1.1 |
| Compressed air requirements | | | | |
| Discharge valves | 80 psi @ 0.2 ft ³ /min {5.5 bars @ 0.09 liters/sec}; 1/4 in. NPT fitting | | | |
| Compressed air feeder | 40 psi @ 2.0 ft ³ /min {2.8 bars @ 0.94 liters/sec}; 1/4 in. NPT fitting | | | |
| Maximum loader sizes§ | | | | |
| Number of 20 inch loaders | 2 | 2 | 2 | 3 |
| Number of 15 inch loaders | 2 | 4 | 5 | 6 |

MOUNTING INTERFACE

IB04 (4) 9/16 in. {14.3 mm} diameter bolt holes

4 in. {101.6 mm} diameter through hole

8 in. {203.2 mm} square bolt pattern

14.5 in. {368.3 mm}

16 in. {406.4 mm}

15 in. {381 mm}

20 in. {508 mm}

SPECIFICATION NOTES:

* Maximum throughput rates are based on using all dispense valves. Use of feeders for minor ingredients will reduce this rate.

† Feeders will increase width and depth dimensions. Please refer to feeder specification.

‡ Each auger feeder requires an additional 1 amp @ 120V or 0.5 amp @ 240V.

§ Maximum loader sizes may be used only when the loader is adjacent to loaders of a smaller size.

APPLICATION NOTE:

We recommend using a flow control valve when mounting the blender to a stand, surge bin or hopper.



SPECIFICATIONS

**GRAVIMETRIC BATCH BLENDERS
WSB 1840, 1850 and 1860 Models**

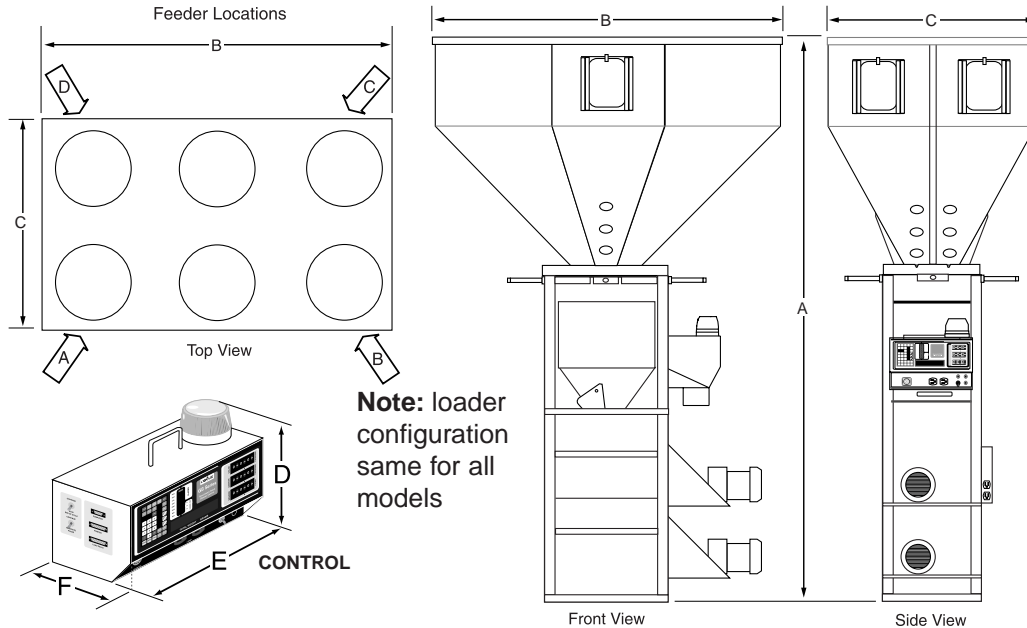

| MODELS | WSB1840 | WSB1850 | WSB1860 |
|--|---|----------------|----------------|
| Performance characteristics | | | |
| Batch size lbs (g) | 39.7 {18000} | 39.7 {18000} | 39.7 {18000} |
| Maximum throughput lbs/hr {kg/hr}* | 4114 {1866} | 3160 {1433} | 2566 {1164} |
| Bin Capacity - Main Ingredient ft ³ {liter} | 6.7 {189.7} | 6.7 {189.7} | 3.8 {107.6} |
| Bin Capacity - Minor Capacity ft ³ {liter} | 3.8 {107.6} | 3.8 {107.6} | 3.8 {107.6} |
| Maximum number of materials | 8 | 9 | 10 |
| Number of discharge valves | 4 | 5 | 6 |
| Number of additive feeders | up to 4 | up to 4 | up to 4 |
| Control Software (# of components) | 4 or 12 | 12 | 12 |
| Dimensions inches {mm} | | | |
| A - Height above mounting plate | 93 {2362.2} | 93 {2362.2} | 93 {2362.2} |
| B - Width† | 56.25 {1428.8} | 56.25 {1428.8} | 56.25 {1428.8} |
| C - Depth† | 34.4 {873.8} | 34.4 {873.8} | 34.4 {873.8} |
| D - Controller height | 11.25 {285.75} | 11.25 {285.75} | 11.25 {285.75} |
| E - Controller width | 12.25 {311.15} | 12.25 {311.15} | 12.25 {311.15} |
| F - Controller depth | 8.19 {208.03} | 8.19 {208.03} | 8.19 {208.03} |
| Weight lbs {kg} | | | |
| Installed | 730 {331} | 730 {331} | 730 {331} |
| Shipping | 850 {385.5} | 850 {385.5} | 850 {385.5} |
| Voltage Running load amps‡ | | | |
| 110V/1 phase/60hz (control) | 0.3 | 0.3 | 0.3 |
| 220V/1 phase/60hz (mixer) | 8.2 | 8.2 | 8.2 |
| 220V/1 phase/60hz (control) | 0.2 | 0.2 | 0.2 |
| 220V/1 phase/60hz (mixer) | 8.2 | 8.2 | 8.2 |
| 220V/1 phase/50hz (control) | 0.2 | 0.2 | 0.2 |
| 220V/3 phase/50hz (mixer) | 4.4 | 4.4 | 4.4 |
| 400V/3 phase/50hz (mixer) | 2.2 | 2.2 | 2.2 |
| Compressed air requirements | | | |
| Discharge valves | 80 psi @ 0.2 ft ³ /min {5.5 bars @ 0.09 liters/sec} 1/4 in. NPT fitting | | |
| Maximum loader sizes § | | | |
| Number of 20 inch loaders | 2 | 2 | 3 |
| Number of 15 inch loaders | 4 | 5 | 6 |

MOUNTING INTERFACE

IB04 (4) 9/16 in. {14.3 mm} diameter bolt holes

4 in. {101.6 mm} diameter through hole 8 in. {203.2 mm} square bolt pattern

SPECIFICATION NOTES:

* Maximum throughput rates are based on using all dispense valves and 35 lb/ft³ pelletized material. Use of feeders will reduce this rate.

† Feeders will increase width and depth dimensions. Please refer to feeder specifications.

‡ Each auger feeder requires an additional 1 amp @ 120V or 0.5 amp @ 240V.

§ Maximum loader sizes may be used only when the loader is adjacent to loaders of a smaller diameter.



THE INFORMATION CONTAINED IN THIS DRAWING IS THE SOLE PROPERTY OF MAGUIRE PRODUCTS, INC. ANY REPRODUCTION IN PART OR WHOLE WITHOUT THE WRITTEN PERMISSION OF MAGUIRE PRODUCTS, INC. IS PROHIBITED.

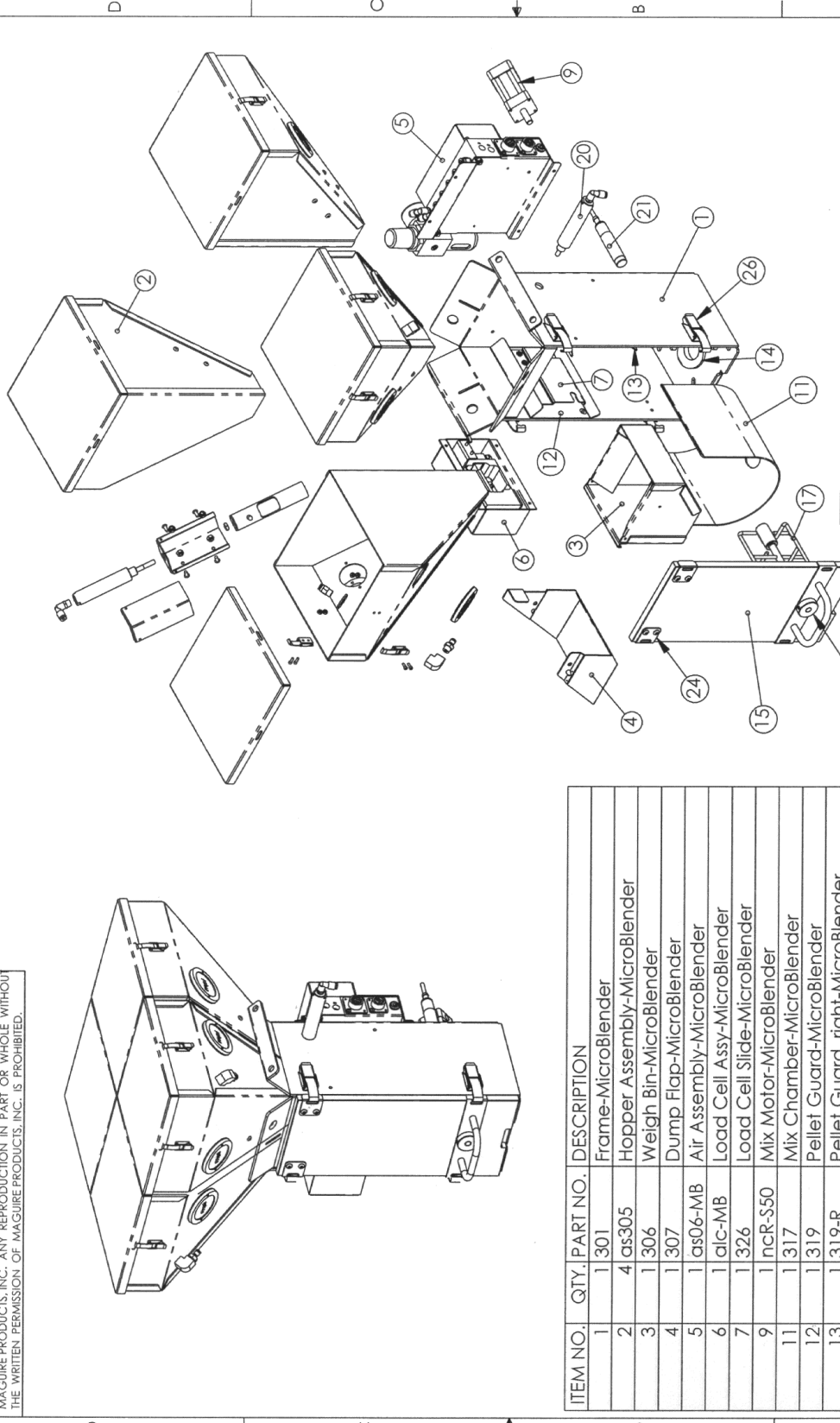

MAGUIRE

MicroBlender
Isometric Exploded View

| | | | |
|--------------------------|----------|-------|-----|
| SIZE | DWG. NO. | NAME | OF |
| A | EXPL-MB | SHEET | 1 |
| File Name: WSB-MB Xplode | | SCALE | 1:8 |

UNLESS OTHERWISE SPECIFIED
DIMENSIONS ARE IN INCHES
TOLERANCES ARE:
FRACTIONS DECIMALS ANGLES
±1/32 .XX±.02 ± 1
 .XXX±.010

| | | |
|----------------------|-----|------|
| MATERIAL | --- | |
| FINISH | --- | |
| DO NOT SCALE DRAWING | | |
| REV | ECN | DATE |
| - | - | - |

| ITEM NO. | QTY. | PART NO. | DESCRIPTION |
|----------|------|----------|--|
| 1 | 1 | 301 | Frame-MicroBlender |
| 2 | 4 | as305 | Hopper Assembly-MicroBlender |
| 3 | 1 | 306 | Weigh Bin-MicroBlender |
| 4 | 1 | 307 | Dump Flap-MicroBlender |
| 5 | 1 | as06-MB | Air Assembly-MicroBlender |
| 6 | 1 | alc-MB | Load Cell Assy-MicroBlender |
| 7 | 1 | 326 | Load Cell Slide-MicroBlender |
| 9 | 1 | ncR-350 | Mix Motor-MicroBlender |
| 11 | 1 | 317 | Mix Chamber-MicroBlender |
| 12 | 1 | 319 | Pellet Guard-MicroBlender |
| 13 | 1 | 319-R | Pellet Guard, right-MicroBlender |
| 14 | 1 | 318 | Saddle-MicroBlender |
| 15 | 1 | 380 | Front Window-MicroBlender |
| 17 | 1 | as325 | Mix Blade Assembly |
| 18 | 1 | 323 | Collar-MicroBlender Mix shaft |
| 20 | 1 | ncv13 | Air Cyl-1/2 stroke, heavy spring w/ bumper |
| 21 | 1 | asps-03 | Level Sensor-18m w/ twist plug |
| 24 | 2 | 1886-L | Latch Plate, small-MicroBlender |
| 26 | 4 | hl04 | Latch, Southco Series 50 short |

THE INFORMATION CONTAINED IN THIS DRAWING IS THE SOLE PROPERTY OF MAGUIRE PRODUCTS, INC. ANY REPRODUCTION IN PART OR WHOLE WITHOUT THE WRITTEN PERMISSION OF MAGUIRE PRODUCTS, INC. IS PROHIBITED.

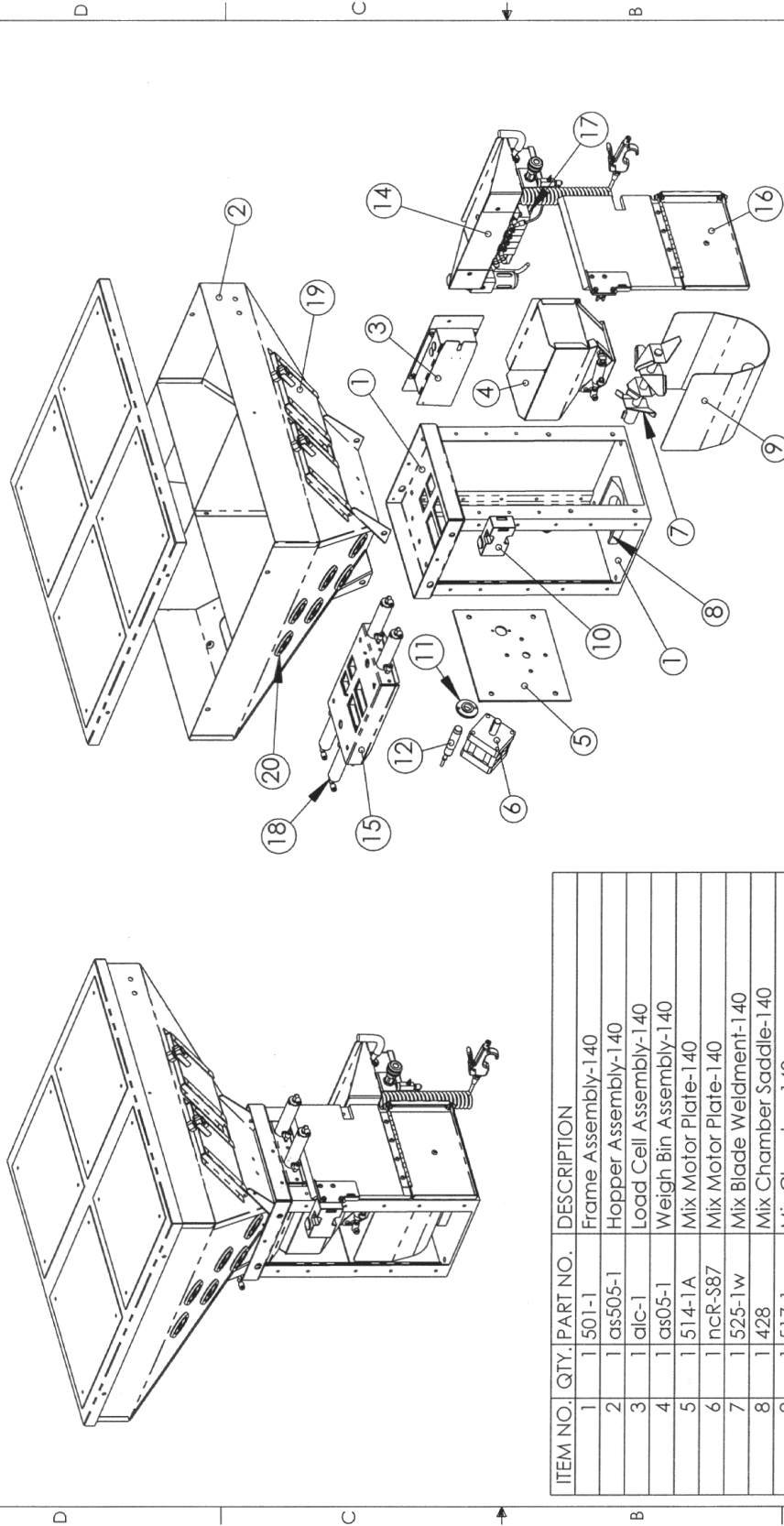

| ITEM NO. | QTY. | PART NO. | DESCRIPTION |
|----------|------|----------|---------------------------------------|
| 1 | 1 | 501-1 | Frame Assembly-140 |
| 2 | 1 | as505-1 | Hopper Assembly-140 |
| 3 | 1 | alc-1 | Load Cell Assembly-140 |
| 4 | 1 | as05-1 | Weigh Bin Assembly-140 |
| 5 | 1 | 514-1A | Mix Motor Plate-140 |
| 6 | 1 | incR-S87 | Mix Motor Plate-140 |
| 7 | 1 | 525-1w | Mix Blade Weldment-140 |
| 8 | 1 | 428 | Mix Chamber Saddle-140 |
| 9 | 1 | 517-1 | Mix Chamber-140 |
| 10 | 1 | esle | Safety Interlock Switch |
| 11 | 1 | 329 | Mount-18mm Proximity Sensor |
| 12 | 1 | asps-02 | Proximity Sensor |
| 14 | 1 | as06-7 | Air Solenoid Set-7 valve |
| 15 | 1 | as539-1 | Valve Assembly-140 |
| 16 | 1 | as583-1 | Front Door Assembly-140 |
| 17 | 1 | inv24-7 | Air Solenoid Set, 24V, 7 Valves |
| 18 | 4 | ncyl1.5 | Air Cylinder, 1 1/2 Stroke, 1.06 Bore |
| 19 | 4 | as505-1W | WSB Hopper Window Assy-small |
| 20 | 8 | psa13 | MPI Sight Glass |

MAGUIRE

WSB 140
Exploded View

| | | | |
|-----------------------------|----------|-------|--------|
| SIZE | DWG. NO. | SHEET | 1 OF 1 |
| A | EXPL-140 | NAME | Sheet1 |
| CAD FILE: 140 Exploded View | | | SCALE |
| | | | 1:2 |

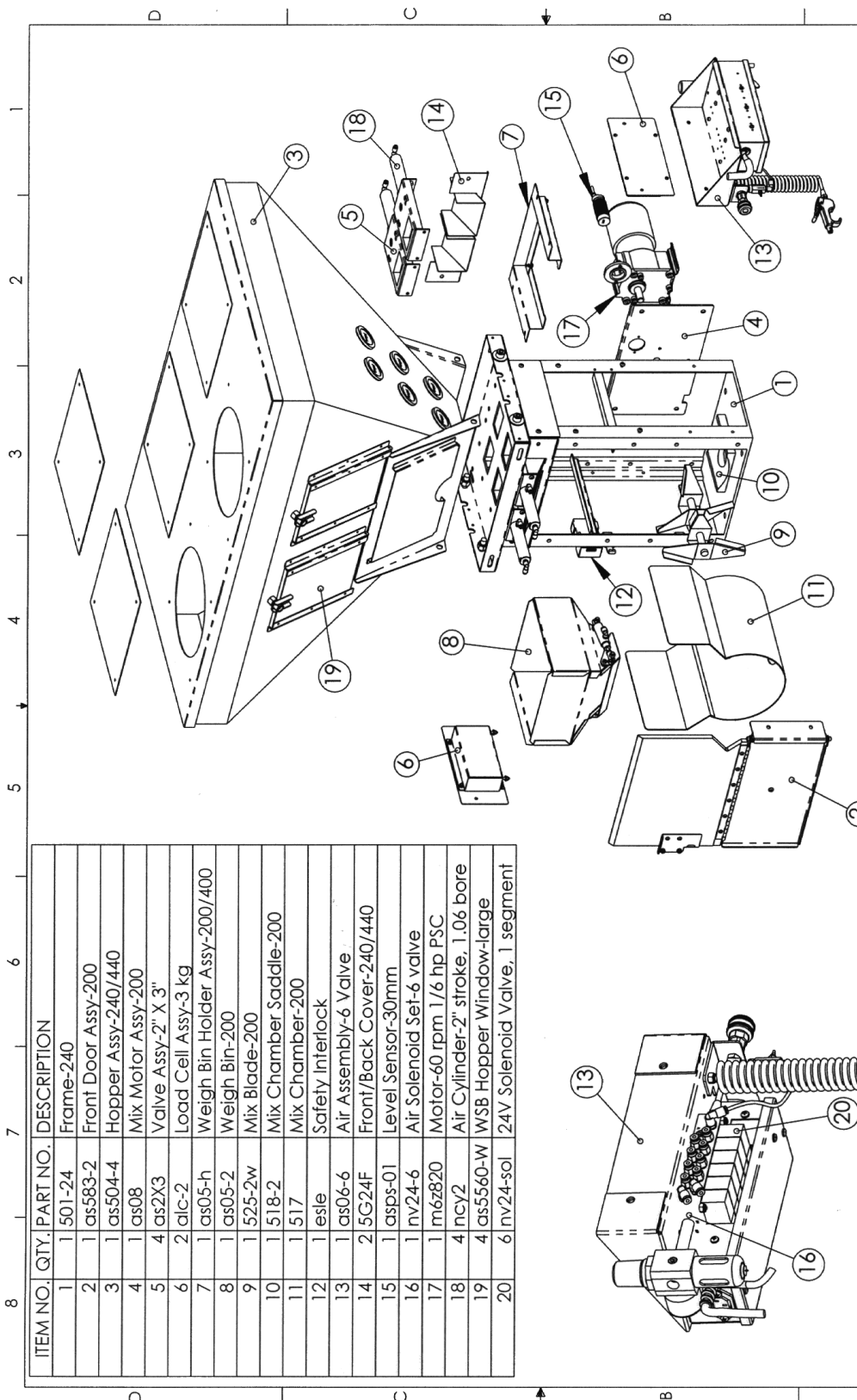

| ITEM NO. | QTY. | PART NO. | DESCRIPTION |
|----------|------|----------|-----------------------------------|
| 1 | 1 | 501-24 | Frame-240 |
| 2 | 1 | as583-2 | Front Door Assy-200 |
| 3 | 1 | as504-4 | Hopper Assy-240/440 |
| 4 | 1 | as08 | Mix Motor Assy-200 |
| 5 | 4 | as2X3 | Valve Assy-2" X 3" |
| 6 | 2 | alc-2 | Load Cell Assy-3 kg |
| 7 | 1 | as05-h | Weigh Bin Holder Assy-200/400 |
| 8 | 1 | as05-2 | Weigh Bin-200 |
| 9 | 1 | 525-2w | Mix Blade-200 |
| 10 | 1 | 518-2 | Mix Chamber Saddle-200 |
| 11 | 1 | 517 | Mix Chamber-200 |
| 12 | 1 | esle | Safety Interlock |
| 13 | 1 | as06-6 | Air Assembly-6 Valve |
| 14 | 2 | 5G24F | Front/Back Cover-240/440 |
| 15 | 1 | asps-01 | Level Sensor-30mm |
| 16 | 1 | nv24-6 | Air Solenoid Set-6 valve |
| 17 | 1 | m6z820 | Motor-60 rpm 1/6 hp PSC |
| 18 | 4 | ncy2 | Air Cylinder-2" stroke, 1.06 bore |
| 19 | 4 | as5560-W | WSB Hopper Window-large |
| 20 | 6 | nv24-sol | 24V Solenoid Valve, 1 segment |

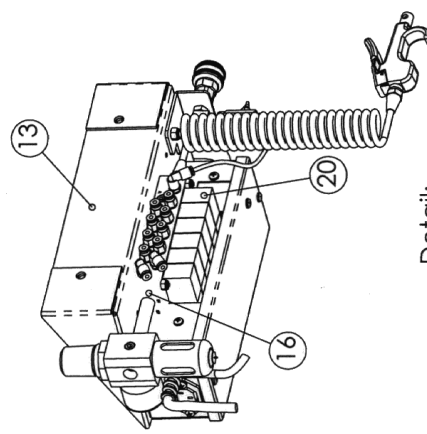

Detail:
Rear View of Controller Tray

MAGUIRE

WSB 240
Exploded View

UNLESS OTHERWISE SPECIFIED
DIMENSIONS ARE IN INCHES
TOLERANCES ARE:

| | | |
|-----------|-------------|--------|
| FRACTIONS | DECIMALS | ANGLES |
| ± 1/32 | .XX ± .02 | ± 1° |
| | .XXX ± .010 | |

MATERIAL: ---
FINISH: ---

DO NOT SCALE DRAWING

| REV | ECN | DATE |
|-----|-----|------|
| - | - | - |

| SIZE | DWG. NO. | SHEET | OF |
|------|----------|-------|----|
| A | EXPL-240 | 1 | 1 |

NAME: SHEET1
SCALE: 1:2

CAD FILE: WSB-240 Exploded

THE INFORMATION CONTAINED IN THIS DRAWING IS THE SOLE PROPERTY OF
MAGUIRE PRODUCTS, INC. ANY REPRODUCTION IN PART OR WHOLE WITHOUT
THE WRITTEN PERMISSION OF MAGUIRE PRODUCTS, INC. IS PROHIBITED.

8 7 6 5 4 3 2 1

| ITEM NO. | QTY. | PART NO. | DESCRIPTION |
|----------|------|----------|-----------------------------------|
| 1 | 1 | 501-420 | WSB 420 Frame |
| 2 | 1 | as583-4 | Front Door Assy-400 |
| 3 | 1 | as504 | Hopper Assy-220/420 |
| 4 | 1 | as08-4 | Mix Motor Assy-400 |
| 5 | 2 | as52 | Valve Assy-3" round |
| 6 | 2 | alc-4 | Load Cell Assy-3 kg |
| 7 | 1 | as05-h | Weigh Bin Holder Assy-200/400 |
| 8 | 1 | as05-4 | Weigh Bin-400 |
| 9 | 1 | 525-4w | Mix Blade-400 |
| 10 | 1 | 518-4 | Mix Chamber Saddle-400 |
| 11 | 1 | 517-4 | Mix Chamber-400 |
| 12 | 1 | esle | Safety Interlock |
| 13 | 1 | as06-4 | WSB Tray & Air Assy-4 valve |
| 14 | 2 | 5g22s | Side Enclosure-220/420 |
| 15 | 1 | asps-01 | Level Sensor-30mm |
| 16 | 1 | nv24-4 | Air Solenoid Set-4 valve |
| 17 | 1 | m6z818 | Motor-30 rpm 1/6 hp PSC |
| 18 | 2 | ncyl15 | Air Cylinder-3" stroke, 1.06 bore |
| 19 | 2 | as505-1w | WSB Hopper Window-small |
| 20 | 4 | nv24-sol | 24V Solenoid Valve, 1 segment |

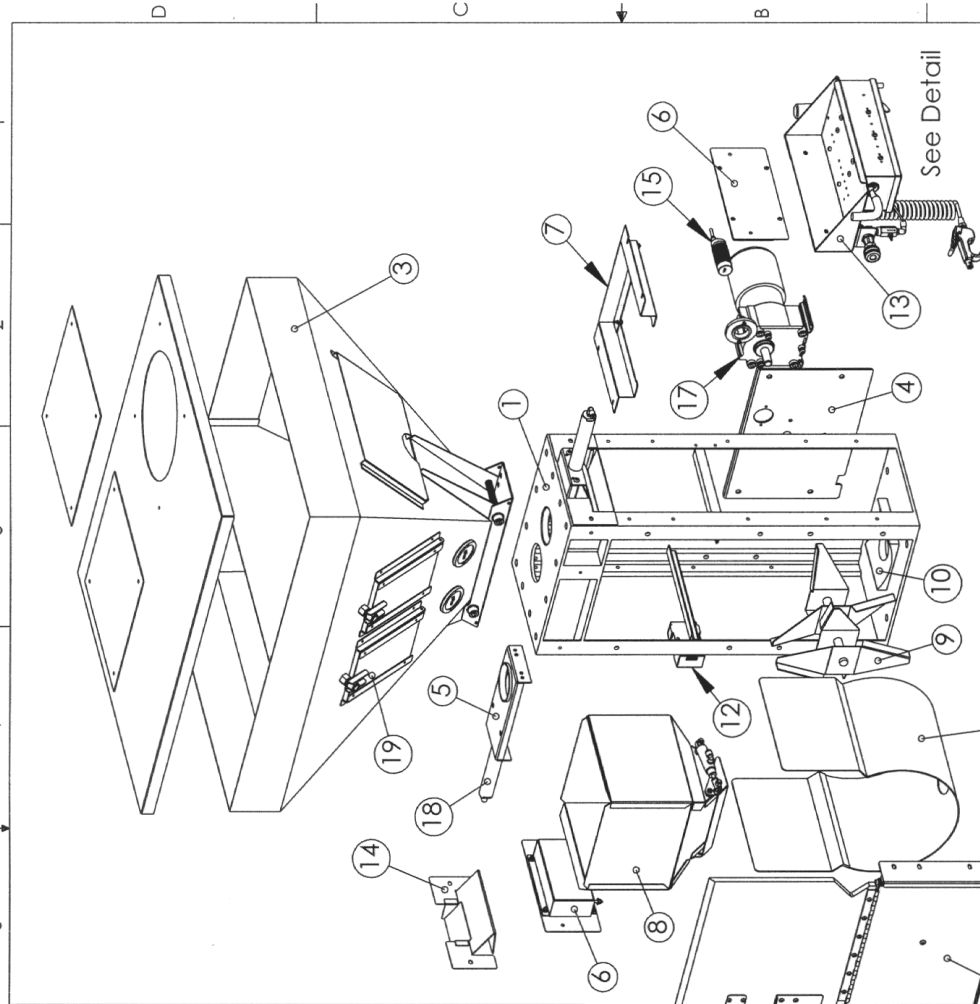

MAGUIRE

WSB 420 Exploded View

UNLESS OTHERWISE SPECIFIED
DIMENSIONS ARE IN INCHES
TOLERANCES ARE:

| FRACTIONS | DECIMALS | ANGLES |
|-----------|----------|--------|
| ± 1/32 | ± .01 | ± 1° |
| XXX ± .00 | | |
| XXX ± .00 | | |

| MATERIAL | FINISH |
|----------|--------|
| | |

| REV | ECN | DATE |
|-----|-----|------|
| - | - | - |

| SIZE | DWG. NO. | SHEET | OF |
|------|----------|-------|----|
| A | EXPL-420 | 1 | 1 |

DO NOT SCALE DRAWING

CAD FILE: WSR-420 Exploded

NAME: Sheet1

SCALE: 1:12

Detail:
Rear View of Controller Tray

THE INFORMATION CONTAINED IN THIS DRAWING IS THE SOLE PROPERTY OF
MAGUIRE PRODUCTS, INC. ANY REPRODUCTION IN PART OR WHOLE WITHOUT
THE WRITTEN PERMISSION OF MAGUIRE PRODUCTS, INC. IS PROHIBITED.

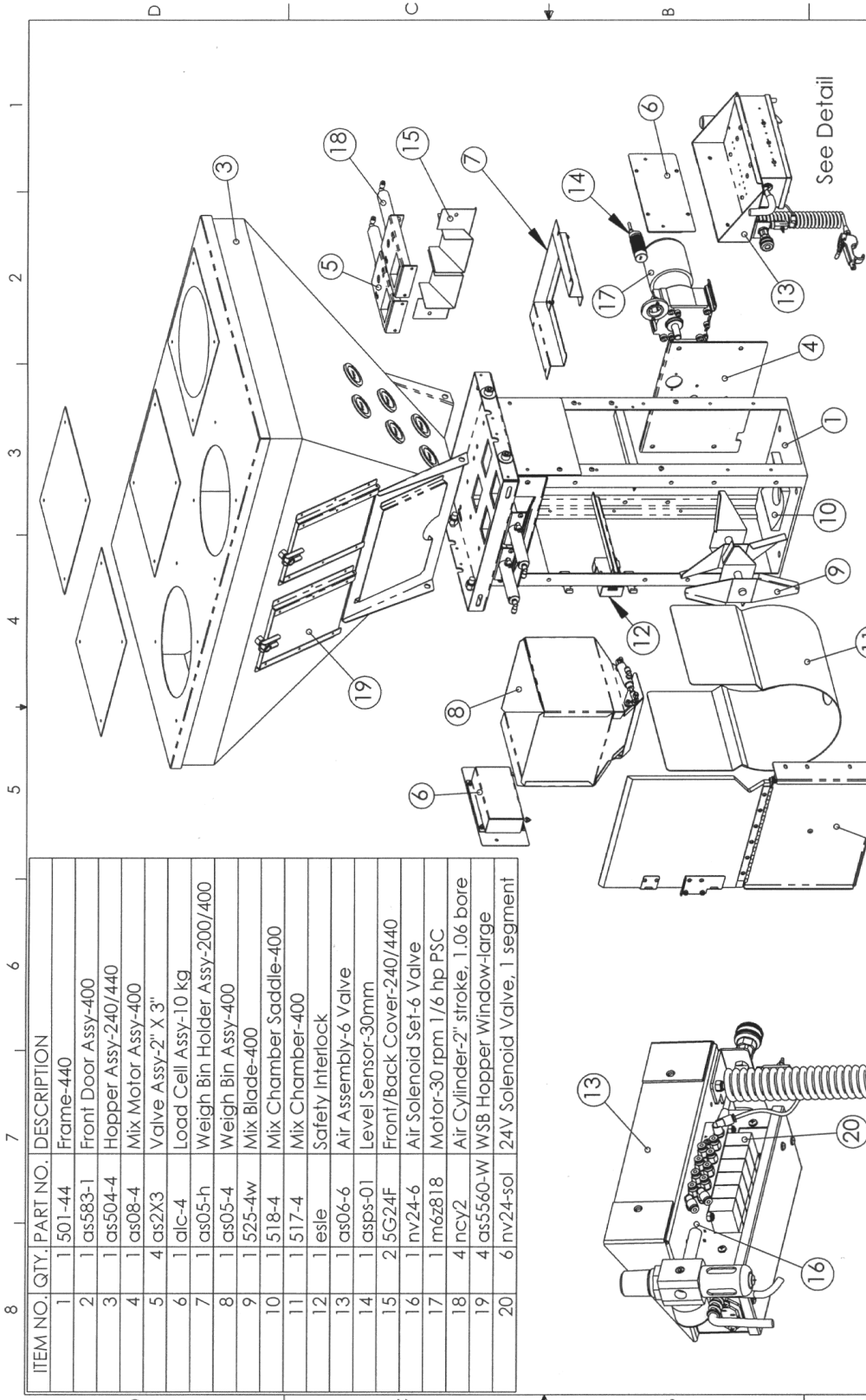

| ITEM NO. | QTY. | PART NO. | DESCRIPTION |
|----------|------|----------|-----------------------------------|
| 1 | 1 | 501-44 | Frame-440 |
| 2 | 1 | as583-1 | Front Door Assy-400 |
| 3 | 1 | as504-4 | Hopper Assy-240/440 |
| 4 | 1 | as08-4 | Mix Motor Assy-400 |
| 5 | 4 | as2X3 | Valve Assy-2" X 3" |
| 6 | 1 | alc-4 | Load Cell Assy-10 kg |
| 7 | 1 | as05-h | Weigh Bin Holder Assy-200/400 |
| 8 | 1 | as05-4 | Weigh Bin Assy-400 |
| 9 | 1 | 525-4w | Mix Blade-400 |
| 10 | 1 | 518-4 | Mix Chamber Saddle-400 |
| 11 | 1 | 517-4 | Mix Chamber-400 |
| 12 | 1 | esle | Safety Interlock |
| 13 | 1 | as06-6 | Air Assembly-6 Valve |
| 14 | 1 | asps-01 | Level Sensor-30mm |
| 15 | 2 | 5G24F | Front/Back Cover-240/440 |
| 16 | 1 | nv24-6 | Air Solenoid Set-6 Valve |
| 17 | 1 | m6z818 | Motor-30 rpm 1/6 hp PSC |
| 18 | 4 | ncv2 | Air Cylinder-2" stroke, 1.06 bore |
| 19 | 4 | as5560-w | WSB Hopper Window-large |
| 20 | 6 | nv24-sol | 24V Solenoid Valve, 1 segment |

MAGUIRE
 WSB 440
 Exploded View

UNLESS OTHERWISE SPECIFIED
 DIMENSIONS ARE IN INCHES
 TOLERANCES ARE:
 FRACTIONS DECIMALS ANGLES
 ±1/32 .XX ± .02 ±1°
 .XXX ± .010

| MATERIAL | FINISH | DO NOT SCALE | DRAWING |
|----------|--------|--------------|---------|
| | | | |

| REV | ECN | DATE |
|-----|-----|------|
| - | - | - |

THE INFORMATION CONTAINED IN THIS DRAWING IS THE SOLE PROPERTY OF
 MAGUIRE PRODUCTS, INC. ANY REPRODUCTION IN PART OR WHOLE WITHOUT
 THE WRITTEN PERMISSION OF MAGUIRE PRODUCTS, INC. IS PROHIBITED.

SIZE DWG. NO. SHEET 1 OF 1
 NAME EXPL-440
 SCALE 1:2
 CAD FILE: WSB-440 Exploded

WSB 940 HOPPER LID

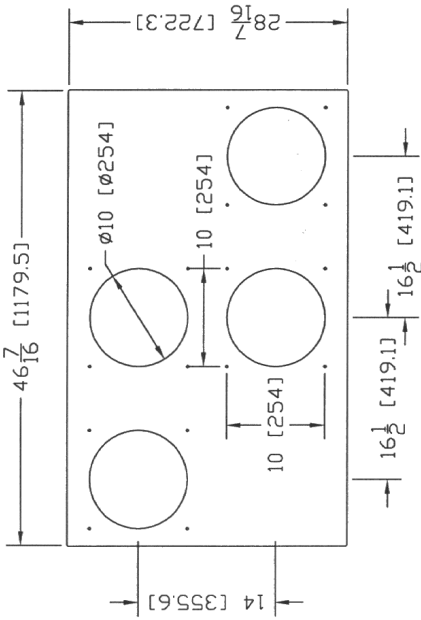

MODEL WSB-940
 * COMPARTMENTS 1 & 2 - 3.4 CU. FT. [96.3 LITRE]
 * COMPARTMENTS 3 & 4 - 1.2 CU. FT. [34 LITRE]

WSB 940 HOPPER-TOP VIEW

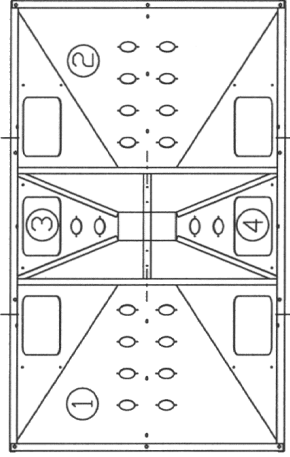

WSB 940 FRONT VIEW

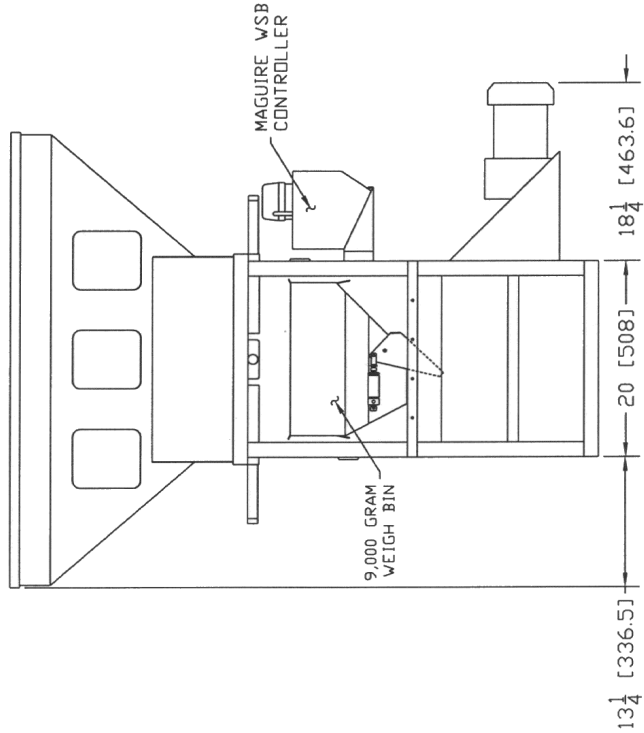

WSB 940 SIDE VIEW

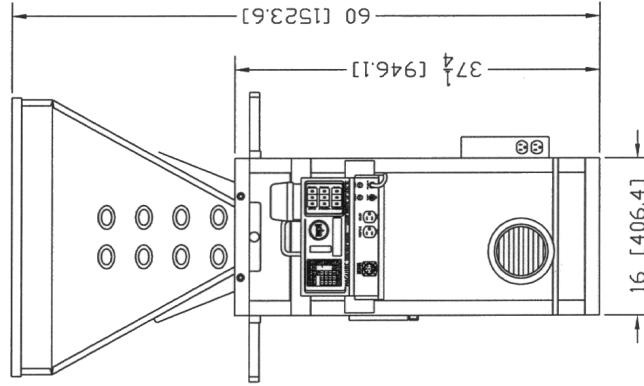

WSB-940 FOOTPRINT

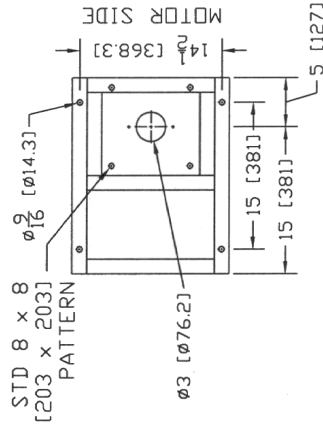

MAGUIRE WEIGH
 SCALE BLENDER
 MODEL WSB-940

| | |
|---|------------------------|
| Maguire Products Inc. Media, PA USA (610) 494-5353 FAX: (610) 494-6194 | DATE DRAWN 11/15/94 |
| DRAWN BY: CGC | SHEET: 1 OF 1 |
| DATE CHANGED: 8/14/97 | |

NOTE:
 COMPARTMENTS 1 & 2 ARE APPROX. 6.6 CU FT [185 LITRE]
 COMPARTMENTS 3 & 4 ARE APPROX. 2.5 CU FT [70 LITRE]

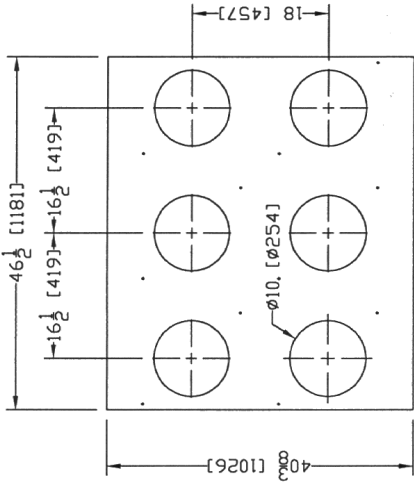

WSB-1840/1860 HOPPER LID

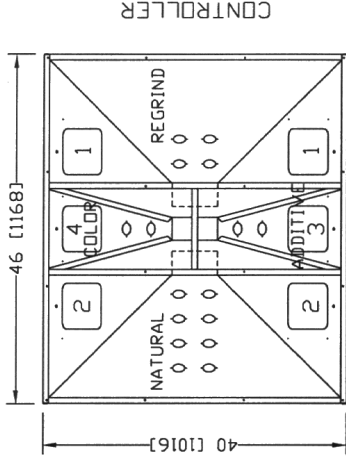
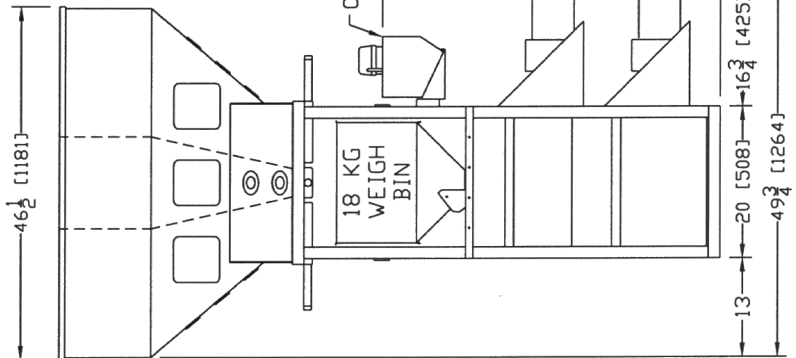

CONTROLLER

HOPPER ALSO AVAILABLE IN
 304 STAINLESS STEEL

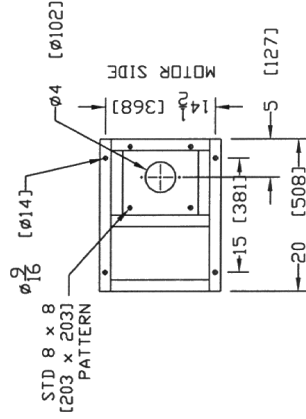
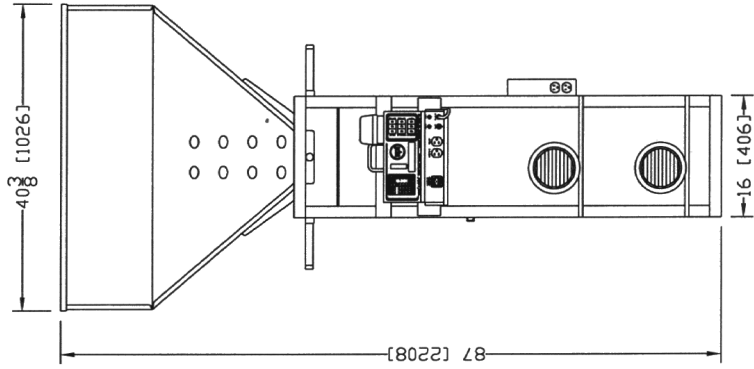

WSB-1800 SERIES
 FOOTPRINT



WSB-1840
 PICTORIAL

Maguire Products Inc.
 Media, PA USA
 (610) 459-4300
 FAX: (610) 459-2700

DRAWN BY: CGC
 DATE DRAWN: 9/15/94
 SHEET: 1 OF 1
 DATE CHANGED: 1/24/97