

Dependable, Customizable Central Cooling Modules

ESE Series Central Chillers are designed for cooling applications between 10 and 250 tons, and can be linked with one control to cool up to 1,500 tons. Water-cooled and remote air-cooled options are available in a wide range of sizes, with a choice of single or dual refrigerant circuits.

These chillers are designed to work in a system. At any point before or after installation, you can link a control panel for up to six chillers with up to twelve total refrigeration circuits.



Model ESEW-100D

Capacities From 10 to 250 Tons

The Conair ESE Central Chillers provide up to 1,500 tons of cooling capacity in a proven design - one that is compact, reliable, and simple. Installation is quick and easy with compact chillers that come with electrical components and sensors already mounted and wired for you.

If your process changes, you don't need to replace the whole machine - you can add new ESE Chillers to the line, and keep them all controllable from a single unit. What's more, the ESE's non-ozone depleting R-410A refrigerant make it a cost-efficient and environmentally-friendly chilling option, easily matched to growing system layouts.

▶ Resilient construction

ESE Chillers are built in an ISO 9001-certified facility using the highest quality materials available, including stainless steel evaporators to resist corrosion. Scroll compressors are direct-drive and hermetic to minimize the need for maintenance. Water-cooled models are equipped with a filtration system to keep out debris and prevent clogs.

▶ Simple installation and maintenance

The compact chiller is factory wired and piped, ready to be connected and activated upon arrival. Components are easy to access thanks to the multi-leveled galvanized steel frame.

▶ Robust PLC control system

The ESE enables quick monitoring and control, using a clear, simple-to-understand display. A single high-resolution LCD touch-screen interface can be connected to up to 6 chillers with individual settings for each. There are also functions available for automating run time and low-load cycling limits to extend compressor life.

▶ NEMA-12 standard control panels

The ESE's NEMA-12 control panel features UL-508A safety certification. The control circuit is isolated from static interference, to ensure stability and precision as you manage your cooling processes.



How it Works

Process fluid enters through the process return connection to the recirculation tank. The recirculation pump moves it through the brazed plate evaporator cooled by R-410A refrigerant, back to the tank, and out through the process supply connection.

Remote air-cooled ESER model:

The brazed plate evaporator is supplied refrigerant from a remote air condenser, provided with the ESER model chiller.

Water-cooled ESEW model (flow diagram below):

Refrigerant is provided from a shell and tube water cooling condenser, which can be supplied with condenser water from a preexisting cooling tower or a reservoir provided as an option.

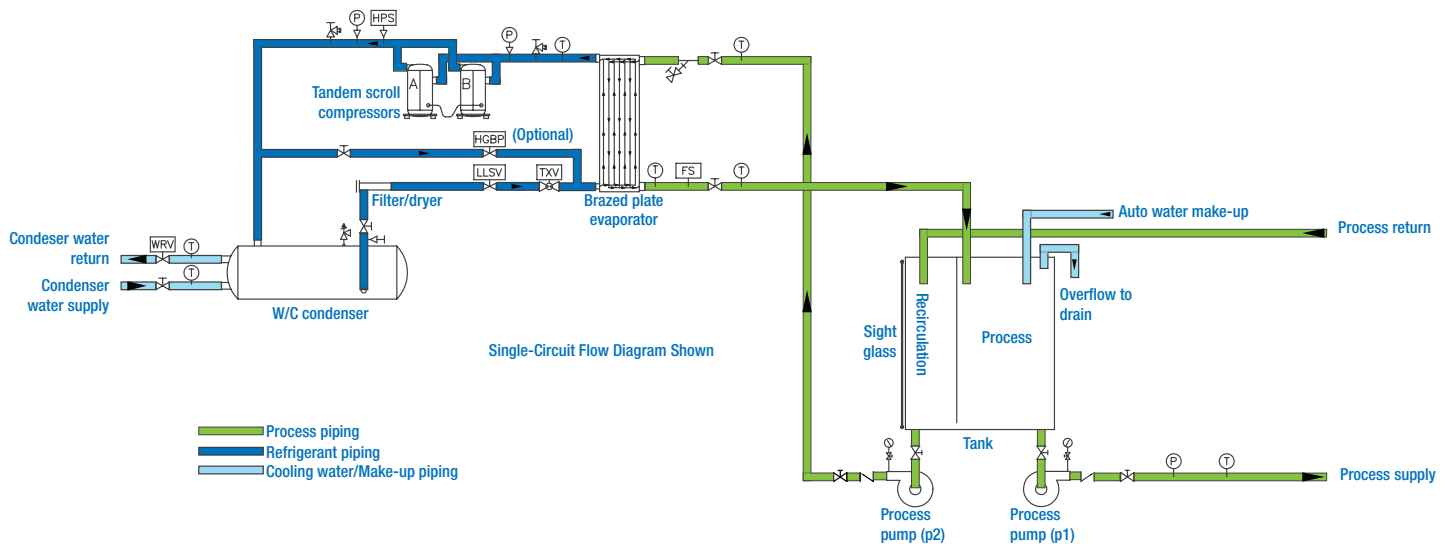

Options

- Hot gas bypass valve**
 Install a failsafe for low- or variable-volume systems to minimize heat changes due to compressor cycling.
- Integral reservoir and pumping system**
 Provide the central chiller with a stainless steel reservoir and pumping system already piped, insulated, and wired for a faster installation. (Available on chillers up to 160 tons.)
- Rotary non-fused disconnect switch**
 5 kA SCCR (Short Circuit Current Rating) rotary non-fused disconnect switch for safe power lock-outs.
- Extended 5 year compressor parts warranty**
 Extend the standard 12 month compressor parts warranty to 60 months for those applications where there is a need for an added level of compressor parts warranty coverage.
- ModBUS RTU communications port***
 Install a RS-485 connector on the PLC which is located inside the control cabinet.
- BACnet communications port***
 Add a ModBUS expansion cassette to the PLC, a ModBUS to BACnet gateway, as well as a RS-485 connector.
- LonWorks communications port***
 Add a ModBUS expansion cassette to the PLC, a ModBUS to LonWorks gateway, as well as a RS-485 connector.

* Note that the ESE Chiller is only able to operate using one communications port option, so only one communications port option is available.



Specifications

ESEW and ESER model chillers

Diagrams shown with water-cooled integral reservoir and pumping system option. Dimensions A, B, and C reflect chillers without reservoir.

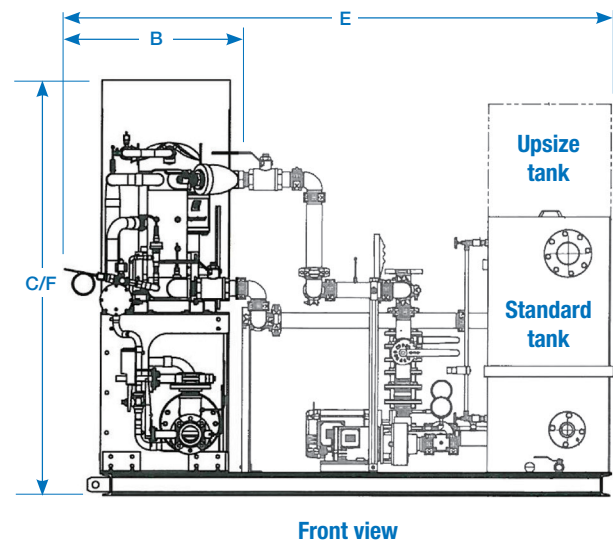
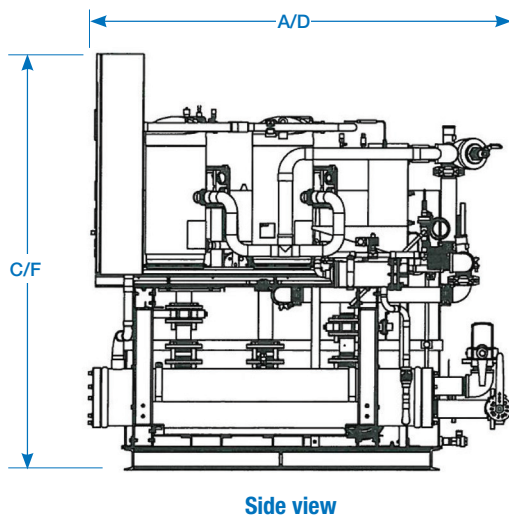
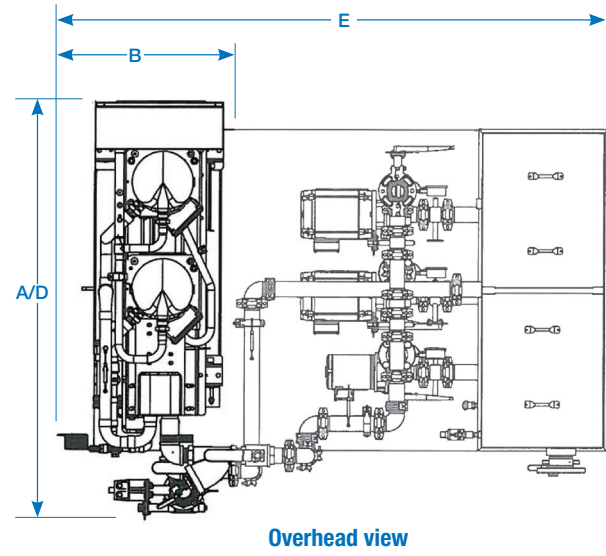
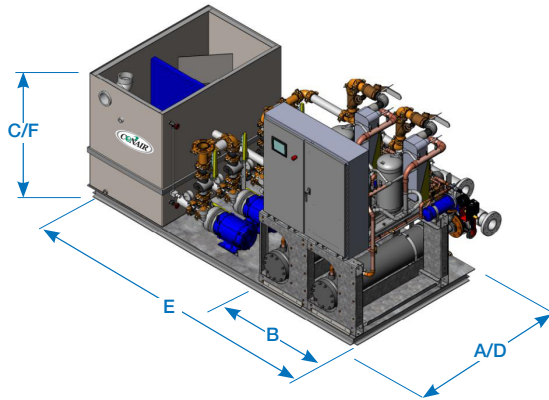

Specification Notes (see following pages)

Remote air-cooled models:

- * Cooling capacity when cooling water with 50°F set point, 60°F return, 95°F condenser air, R-410A refrigerant.
- † MCA is minimum circuit ampacity (for wire sizing).

Water-cooled models:

- ** Cooling capacity when cooling water with 50°F set point, 60°F return, 85°F condenser water, R-410A refrigerant.
- †† MCA is minimum circuit ampacity (for wire sizing). MOP is maximum overcurrent protection, used for sizing main power protection device.
- †† To keep the shipping dimensions within a 102 inch width for standard flatbed shipping, the condenser inlet manifold is removed for shipment.

Operating weight varies based on system refrigeration charge and operating conditions.

Specifications may change without notice. Check with a Conair representative for the most current information.



Specifications Water-Cooled Single-Circuit Chiller 60 Hz

Model	ESEW-010S	ESEW-015S	ESEW-020S	ESEW-025S	ESEW-030S	ESEW-040S	ESEW-050S	ESEW-060S	ESEW-080S	ESEW-100S	ESEW-120S
Performance characteristics											
Cooling capacity** tons	10.9	16.1	22.2	27.3	32.6	42.2	53.3	68.4	86.2	110.0	128.0
Setpoint range °F {°C}	20 to 80 {-2.6 to 26}										
Compressors (qty)	2	2	2	2	2	2	2	2	2	3	
Process fluid in/out - Standard	1 1/2 inch		2 inch		2 1/2 inch		3 inch	4 inch			
Process fluid in/out - High Flow	2 inch	2 1/2 inch		3 inch		4 inch			N/A	6 inch	
Condenser water in/out inches	1 1/2	2		2 1/2		3		4			
Dimensions, weights, amps (chiller only)											
A - Length inches {mm}	68 {1727}	72 {1828}	75 {1905}		77 {1956}	102 {2591}	92 {2337}	102 {2591}		123 {3124}	125 {3175}
B - Width inches {mm}	30 {762}					36 {914}			30 {762}		
C - Height inches {mm}	68 {1727}									70 {1778}	71 {1803}
Shipping weight lbs {kg}	990 {449}	1072 {486}	1150 {522}	1189 {539}	1339 {607}	1763 {800}	1802 {817}	2294 {1041}	2467 {1119}	3230 {1465}	3250 {1475}
Operating weight lbs {kg}	1005 {456}	1092 {495}	1179 {535}	1222 {554}	1376 {624}	1823 {827}	1872 {849}	2380 {1080}	2557 {1160}	3330 {1511}	3350 {1520}
MCA @ 460/3/60 ^{††} amps	23	34	41	53	61	70	86	124	165	205	238
MOP @ 460/3/60 ^{††} amps	30	45	50	70	80	100	110	175	225	250	300
Dimensions, weights, amps (chiller with standard flow reservoir option, 10°F ΔT process, 10°F ΔT chiller)											
Reservoir capacity gal {l}	275 {1041}						450 {1703}		N/A	N/A	
Pump models (process/chiller)	5D/1.5A				7.5D/2A	10D/2A	10D/3A		15D/3A	N/A	N/A
Process connection size in	1 1/2		2		2 1/2		3		4	N/A	N/A
Condenser water in/out inches	1 1/2	2		2 1/2		3		4		N/A	N/A
D - Length inches {mm}	99 {2515}						102 {2591}	114 {2896}		N/A	N/A
E - Width inches {mm}	68 {1727}	72 {1829}	75 {1905}		78 {1981}	98 {2489}	102 {2591}	101 {2565}	101 {2565}	N/A	N/A
F - Height inches {mm}	73 {1854}									N/A	N/A
Shipping Weight lbs {kg}	2337 {1060}	2418 {1097}	2496 {1132}	2537 {1151}	2769 {1256}	3238 {1469}	3374 {1530}	4147 {1881}	4370 {1982}	N/A	N/A
Operating Weight lbs {kg}	4631 {2101}	4712 {2137}	4790 {2173}	4831 {2191}	5063 {2297}	5532 {2509}	5668 {2571}	7901 {3584}	8124 {3685}	N/A	N/A
MCA @ 460/3/60 amps	33	43	49	60	72	83	99	132	178	N/A	N/A
MOP @ 460/3/60 amps	40	50	60	80	100	110	125	175	250	N/A	N/A
Dimensions, weights, amps (chiller with high flow reservoir option 1, 5°F ΔT process, 10°F ΔT chiller)											
Reservoir capacity gal {l}	400 {1514}						650 {2461}		N/A	N/A	
Pump models (process/chiller)	5D/1.5A	7.5D/1.5A	10D/1.5A		10D/2A	15D/2A	15D/3A	20D/3A	25D/3A	N/A	N/A
Process connection size	2 inch	2 1/2 inch		3 inch		4 inch			6 inch	N/A	N/A
Condenser water in&out	1 1/2 inch	2 inch		2 1/2 inch		3 inch		4 inch		N/A	N/A
D - Length inches {mm}	99 {2515}						102 {2591}	114 {2896}		N/A	N/A
E - Width inches {mm}	68 {1727}	72 {1829}	75 {1905}		78 {1981}	98 {2489}	102 {2591}	101 {2565}		N/A	N/A
F - Height inches {mm}	73 {1854}									N/A	N/A
Shipping Weight lbs {kg}	2850 {1293}	2950 {1338}	3100 {1406}	3150 {1429}	3450 {1565}	4000 {1814}	4250 {1928}	4950 {2245}	5750 {2608}	N/A	N/A
Operating Weight lbs {kg}	6200 {2812}	6300 {2858}	6450 {2926}	6500 {2948}	6800 {3084}	7350 {3334}	7600 {3447}	10,400 {4717}	11,200 {5080}	N/A	N/A
MCA @ 460/3/60 ^{††} amps	33	48	58	70	79	95	112	155	204	N/A	N/A
MOP @ 460/3/60 ^{††} amps	40	60	70	90	100	125	125	200	250	N/A	N/A



Specifications Water-Cooled Dual-Circuit Chiller 60 Hz

Model	ESEW-020D	ESEW-030D	ESEW-040D	ESEW-050D	ESEW-060D	ESEW-080D	ESEW-100D	ESEW-120D	ESEW-160D	ESEW-200D	ESEW-240D	
Performance characteristics												
Cooling capacity** tons	21.7	32.1	44.3	54.7	65.2	84.5	106.7	136.9	171.0	220.0	256.0	
Setpoint range °F [°C]	20 to 80 {-2.6 to 26}											
Compressors circuit 1 (qty)	2									3		
Compressors circuit 2 (qty)	2									3		
Process fluid in/out - Standard inches	2	2 1/2		3			4		6			
Process fluid in/out - High Flow inches	2 1/2	3	4			6		N/A	8			
Condenser water in/out inches	2	2 1/2	3		4			6				
Dimensions, weights, amps (chiller only)												
A - Length inches {mm}	76 {1930}	77 {1956}	80 {2032}	81 {2057}	87 {2210}	117 {2972}	113 {2870}	119 {3023}	120 {3048}	139 {3531}	141 {3581}	
B - Width inches {mm}	48 {1219}	49 {1245}	50 {1270}		52 {1321}	51 {1295}	52 {1321}	54 {1372}		60 {1524}		
C - Height inches {mm}	68 {1727}									71 {1803}		
Shipping weight lbs {kg}	1925 {748}	2093 {949}	2255 {1025}	2343 {1063}	2657 {1205}	3516 {1595}	3595 {1631}	4361 {1978}	4736 {2148}	5780 {2622}		
Operating weight lbs {kg}	1055 {479}	2133 {968}	2315 {1051}	2409 {1093}	2731 {1199}	3636 {1649}	3735 {1694}	4533 {2056}	4916 {2230}	5980 {2713}		
MCA @ 460/3/60 ^{††} amps	42	64	77	99	116	132	162	233	311	391	457	
MOP @ 460/3/60 ^{††} amps	50	70	90	110	125	150	175	250	350	450	500	
Dimensions, weights, amps (chiller with standard flow reservoir option, 10°F ΔT process, 10°F ΔT chiller)												
Reservoir size gal {l}	275 {1041}				450 {1703}		700 {2650}		1000 {3785}	N/A	N/A	
Pump models (process/chiller)	5D/1.5A	7.5D/2A	10D/2A	10D/3A		15D/3A	15D/5A	20D/7.5F	25D/10E	N/A	N/A	
Process connection size inches	2	2 1/2		3			4		6	N/A	N/A	
Condenser water in/out inches	2	2 1/2	3		4			6		N/A	N/A	
D - Length inches {mm}	123 {3124}				135 {3429}				148 {3759}	N/A	N/A	
E - Width inches {mm}	74 {1880}		77 {1956}	78 {1981}	81 {2057}	98 {2489}	102 {2591}#	111 {2819}#		N/A	N/A	
F - Height inches {mm}	73 {1854}			75 {1905}			79 {2007}		90 {2286}	N/A	N/A	
Shipping Weight lbs {kg}	3486 {1581}	3748 {1700}	3948 {1791}	4086 {1853}	4546 {2062}	5390 {2445}	6067 {2752}	7160 {3248}	8168 {3705}	N/A	N/A	
Operating Weight lbs {kg}	5780 {2622}	6042 {2741}	6229 {2825}	6362 {2886}	8300 {3765}	9144 {4148}	11,936 {5414}	12,999 {5896}	16,510 {7489}	N/A	N/A	
MCA @ 460/3/60 ^{††} amps	53	78	95	118	134	158	190	267	359	N/A	N/A	
MOP @ 460/3/60 ^{††} amps	60	90	110	125	150	175	225	300	400	N/A	N/A	
Dimensions, weights, amps (chiller with high flow reservoir option 1, 5°F ΔT process, 10°F ΔT chiller)												
Reservoir size gal {l}	400 {1514}				650 {2461}			1000 {3785}			N/A	N/A
Pump models (process/chiller)	10D/1.5A	10D/2A	15D/2A	15D/3A	20D/3A	25D/3A	30D/5A	40D/7.5F	40D/10E	N/A	N/A	
Process connection size inches	2 1/2	3	4			6				N/A	N/A	
Condenser water in/out inches	2	2 1/2	3		4			6				
D - Length inches {mm}	123 {3124}				135 {3429}				148 {3759}	N/A	N/A	
E - Width inches {mm}	74 {1880}		77 {1956}	78 {1981}	81 {2057}	98 {2489}	102 {2591}#	111 {2819}#	111 {2819}#	N/A	N/A	
F - Height inches {mm}	73 {1854}			75 {1905}			79 {2007}		90 {2286}	N/A	N/A	
Shipping Weight lbs {kg}	5950 {2699}	6400 {2903}	6750 {3062}	6950 {3152}	8950 {4060}	10,300 {4672}	13,050 {5919}	14,150 {6418}	18,500 {8391}	N/A	N/A	
Operating Weight lbs {kg}	7200 {3266}	7650 {3470}	8000 {3629}	8200 {3719}	10,900 {4944}	12,250 {5557}	16,250 {7371}	17,250 {7824}	19,500 {8845}	N/A	N/A	
MCA @ 460/3/60 ^{††} amps	61	81	102	125	147	172	210	292	377	N/A	N/A	
MOP @ 460/3/60 ^{††} amps	70	90	110	125	150	200	250	300	400	N/A	N/A	



Specifications Remote Air-Cooled Single-Circuit Chiller 60 Hz

Model	ESE-010S	ESE-015S	ESE-020S	ESE-025S	ESE-030S	ESE-040S	ESE-050S	ESE-060S	ESE-080S	ESE-100S	ESE-120S	
Performance characteristics												
Cooling capacity* tons	10.0	14.9	20.4	25.2	30.1	38.9	48.9	63.6	78.7	101.0	119.0	
Setpoint range °F {°C}	20 to 80 {-2.6 to 26}											
Compressors (qty)	2											
Process fluid in/out - Standard inches	1 1/2		2		2 1/2		3	4				
Process fluid in/out - High Flow inches	2	2 1/2		3		4			N/A	6		
Refrigerant discharge line inches	7/8	1 1/8		1 3/8		1 5/8			2 1/8			
Refrigerant liquid line inches	5/8	7/8		1 1/8			1 3/8	1 5/8	2 1/8			
Dimensions, weights, amps (chiller only)												
A - Length inches {mm}	64 {1626}	65 {1651}	68 {1727}		74 {1880}	102 {2594}	99 {2515}	102 {2594}		123 {3124}	125 {3175}	
B - Width inches {mm}	30 {762}						36 {914}			30 {762}		
C - Height inches {mm}	68 {1727}										64 {1626}	
Shipping weight lbs {kg}	897 {407}	1024 {465}	1060 {481}	1076 {488}	1202 {545}	1554 {705}	1588 {720}	1995 {905}	2161 {980}	2820 {1279}		
Operating weight lbs {kg}	912 {414}	1044 {474}	1090 {494}	1109 {503}	1239 {562}	1614 {732}	1658 {752}	2081 {944}	2251 {1021}	2920 {1325}		
MCA @ 460/3/60 ⁺ amps	23	34	41	53	61	70	86	124	165	205	238	
MOP @ 460/3/60 ⁺ amps	30	45	50	70	80	100	110	175	225	250	300	
Dimensions, weights, amps (chiller with standard flow reservoir option, 10°F ΔT process, 10°F ΔT chiller)												
Reservoir capacity gal {l}	275 {1041}						450 {1703}			N/A	N/A	
Pump models (process/chiller)	5D/1.5A				7.5D/2A	10D/2A	10D/3A		15D/3A	N/A	N/A	
Process connection size inches	1 1/2		2		2 1/2		3		4	N/A	N/A	
Refrigerant discharge line inches	7/8	1 1/8		1 3/8		1 5/8			2 1/8	N/A	N/A	
Refrigerant liquid line inches	5/8	7/8		1 1/8			1 3/8	1 5/8	N/A	N/A		
D - Length inches {mm}	99 {2515}						102 {2591}	114 {2896}			N/A	N/A
E - Width inches {mm}	66 {1676}		67 {1702}		71 {1803}	98 {2489}	102 {2501}	101 {2565}			N/A	N/A
F - Height inches {mm}	73 {1854}										N/A	N/A
Shipping Weight lbs {kg}	2267 {1028}	2370 {1075}	2407 {1092}	2423 {1099}	2628 {1092}	3030 {1374}	3158 {1432}	3846 {1745}	4063 {1893}	N/A	N/A	
Operating Weight lbs {kg}	4561 {2069}	4664 {2116}	4701 {2132}	4717 {2140}	4922 {2233}	5324 {2415}	5452 {2473}	7600 {3447}	7817 {3546}	N/A	N/A	
MCA @ 460/3/60 ⁺ amps	33	43	49	60	72	83	99	132	178	N/A	N/A	
MOP @ 460/3/60 ⁺ amps	40	50	60	80	100	110	125	175	250	N/A	N/A	
Dimensions, weights, amps (chiller with high process flow reservoir option, 5°F ΔT process, 10°F ΔT chiller)												
Reservoir capacity gal {l}	400 {1514}						650 {2461}			N/A	N/A	
Pump models (process/chiller)	5D/1.5A	7.5D/1.5A	10D/1.5A		10D/2A	15D/2A	15D/3A	20D/3A	25D/3A	N/A	N/A	
Process connection size inches	2	2 1/2		3		4			6	N/A	N/A	
Refrigerant discharge line inches	7/8	1 1/8		1 3/8		1 5/8			2 1/8	N/A	N/A	
Refrigerant liquid line inches	5/8	7/8		1 1/8			1 3/8	1 5/8	N/A	N/A		
D - Length inches {mm}	99 {2515}						102 {2591}	114 {2896}			N/A	N/A
E - Width inches {mm}	66 {1676}		67 {1702}		71 {1803}	98 {2489}	102 {2591}			N/A	N/A	
F - Height inches {mm}	73 {1854}										N/A	N/A
Shipping weight lbs {kg}	2800 {1270}	2950 {1338}		3000 {1361}	3300 {1497}	3750 {1701}	4000 {1814}	4600 {2087}	5350 {2427}	N/A	N/A	
Operating weight lbs {kg}	6150 {2790}	6300 {2858}		6350 {2880}	6650 {3016}	7100 {3221}	7350 {3334}	10,050 {4559}	10,800 {4899}	N/A	N/A	
MCA @ 460/3/60 ⁺ amps	33	48	58	70	79	95	112	15	204	N/A	N/A	
MOP @ 460/3/60 ⁺ amps	40	60	70	90	100	125	125	200	250	N/A	N/A	



Specifications Remote Air-Cooled Dual-Circuit Chiller 60 Hz

Model	ESE-020D	ESE-030D	ESE-040D	ESE-050D	ESE-060D	ESE-080D	ESE-100D	ESE-120D	ESE-160D	ESE-200D	ESE-240D
Performance characteristics											
Cooling capacity* tons	20.4	29.9	40.7	50.5	60.2	77.8	97.7	127.2	157.5	201.0	237.0
Setpoint range °F {°C}	20 to 80 {-2.6 to 26}										
Compressors circuit 1 (qty)	2									3	
Compressors circuit 2 (qty)	2									3	
Process fluid in/out - Standard inches	2	2 1/2		3		4			6		
Process fluid in/out - High Flow inches	2 1/2	3	4			6			N/A	8	
Refrig. discharge line/circuit in.	7/8	1 1/8		1 3/8		1 5/8			2 1/8		
Refrig. liquid line/circuit inches	5/8	7/8		1 1/8			1 3/8	1 5/8	2 1/8		
Dimensions, weights, amps (chiller only)											
A - Length inches {mm}	76 {1930}	77 {1956}	80 {2032}	81 {2057}	87 {2210}	117 {2972}	113 {2870}	116 {2946}	120 {3048}	139 {3531}	141 {3581}
B - Width inches {mm}	48 {1219}					49 {1245}			51 {1295}	60 {1524}	
C - Height inches {mm}	68 {1727}									65 {1651}	
Shipping weight lbs {kg}	1722 {721}	1760 {798}	1834 {832}	2091 {949}	2335 {1059}	3061 {1388}	3129 {1419}	3820 {1733}	4069 {1846}	5350 {2427}	5370 {2436}
Operating Weight lbs {kg}	1752 {795}	1800 {817}	1894 {859}	2157 {978}	2409 {1092}	3181 {1445}	3269 {1483}	3992 {1811}	4249 {1927}	5500 {2495}	5570 {2527}
MCA @ 460/3/60 ⁺ amps	42	64	77	99	116	132	162	233	311	391	457
MOP @ 460/3/60 ⁺ amps	50	70	90	110	125	150	175	250	350	450	500
Dimensions, weights, amps (chiller with standard flow reservoir option, 10°F ΔT process, 10°F ΔT chiller)											
Reservoir size gal {}	275 {1041}				450 {1703}		700 {2650}		1000 {3785}	N/A	N/A
Pump models (process/chiller)	5D/1.5A	7.5D/2A	10D/2A	10D/3A		15D/3A	15D/5A	20D/7.5F	25D/10E	N/A	N/A
Process connection size inches	2	2 1/2		3		4			6	N/A	N/A
Refrig. discharge line/circuit in.	7/8	1 1/8		1 3/8		1 5/8			2 1/8	N/A	N/A
Refrig. liquid line/circuit inches	5/8	7/8		1 1/8			1 3/8	1 5/8	N/A	N/A	
D - Length inches {mm}	123 {3124}				135 {3429}			148 {3759}		N/A	N/A
E - Width inches {mm}	66 {1676}		67 {1702}	68 {1727}	71 {1803}	99 {2515}		98 {2489}	101 {2565}	N/A	N/A
F - Height inches {mm}	72 {1829}			75 {1905}			78 {1981}	79 {2007}	90 {2286}	N/A	N/A
Shipping Weight lbs {kg}	3335 {1513}	3634 {1649}	3624 {1644}	3814 {1730}	4224 {1916}	5040 {2286}	5628 {2553}	6478 {2938}	7499 {3402}	N/A	N/A
Operating Weight lbs {kg}	5629 {2553}	5928 {2689}	5918 {2684}	6109 {2771}	7978 {3619}	8794 {3989}	11,467 {5201}	12,317 {5587}	15,841 {7185}	N/A	N/A
MCA @ 460/3/60 ⁺ amps	53	78	95	118	134	158	190	267	359	N/A	N/A
MOP @ 460/3/60 ⁺ amps	60	90	110	125	150	175	225	300	400	N/A	N/A
Dimensions, weights, amps (chiller with high flow reservoir option 1, 5°F ΔT process, 10°F ΔT chiller)											
Reservoir size gal {}	400 {1514}				650 {2461}		1000 {3785}			N/A	N/A
Pump models (process/chiller)	10D/1.5A	10D/2A	15D/2A	15D/3A	20D/3A	25D/3A	30D/5A	40D/7.5F	40D/10E	N/A	N/A
Process connection size inches	2 1/2	3	4			6			N/A	N/A	
Refrig. discharge line/circuit in.	7/8	1 1/8		1 3/8		1 5/8			2 1/8	N/A	N/A
Regrig. liquid line/circuit inches	5/8	7/8		1 1/8			1 3/8	1 5/8	N/A	N/A	
D - Length inches {mm}	123 {3124}				135 {3429}			148 {3759}		N/A	N/A
E - Width inches {mm}	66 {1676}		67 {1702}	68 {1727}	71 {1803}	99 {2515}		98 {2489}	101 {2565}	N/A	N/A
F - Height inches {mm}	72 {1829}			75 {1905}			78 {1981}	79 {2007}	90 {2286}	N/A	N/A
Shipping weight lbs {kg}	3850 {1746}	4200 {1905}	4400 {1996}	4550 {2064}	5050 {2291}	6250 {2835}	7300 {3311}	8100 {3674}	10,300 {4672}	N/A	N/A
Operating weight lbs {kg}	7200 {3266}	7550 {3425}	7750 {3515}	7900 {3583}	10,500 {4763}	11,700 {5307}	15,650 {7099}	16,450 {7462}	18,650 {8459}	N/A	N/A
MCA @ 460/3/60 ⁺ amps	61	81	102	125	147	172	210	292	377	N/A	N/A
MOP @ 460/3/60 ⁺ amps	70	90	110	125	150	200	250	300	400	N/A	N/A



Reservoir Pump Specifications

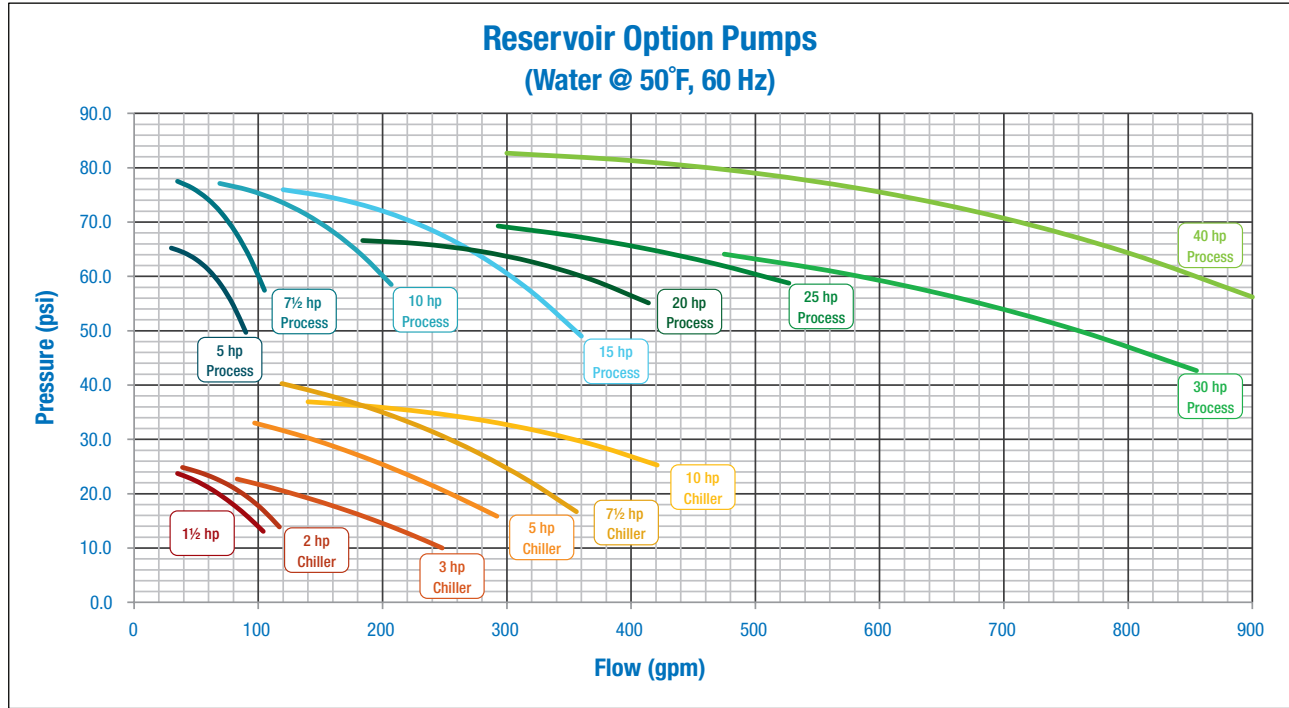

Air Condenser Specifications

Circuit	Model	Chiller model used with*	Dimensions inches {mm}			Shipping weight lb {kg}	Number of fans	MCA @ 460/3/60 amps†	MOP @ 460/3/60 amps†	Refrig. lines inches	
			Length	Width	Height					Inlet per circuit	Outlet per circuit
Single-circuit	KCM014	ESER-010S	83 {2108}	43 {1092}	48 {1219}	415 {188}	2	2.6	15	1 3/8	1 1/8
	KCL023	ESER-015S	113 {2870}	45 {1143}	54 {1372}	680 {308}	2	7.0	15	2 1/8	1 3/8
	KCL030	ESER-020S	113 {2870}	45 {1143}	54 {1372}	720 {327}	2	7.0	15	2 1/8	1 5/8
	KCL037	ESER-025S	113 {2870}	45 {1143}	54 {1372}	1050 {476}	2	7.0	15	2 1/8	1 5/8
	KCL045	ESER-030S	168 {4267}	45 {1143}	54 {1372}	1075 {488}	3	10.1	15	2 5/8	1 5/8
	KCL056	ESER-040S	168 {4267}	45 {1143}	54 {1372}	1450 {658}	3	10.1	15	2 5/8	2 1/8
	KCL068	ESER-050S	223 {5664}	45 {1143}	54 {1372}	1475 {669}	4	16.0	20	2 5/8	2 1/8
	KCL095	ESER-060S	278 {7061}	45 {1143}	54 {1372}	1950 {885}	5	16.0	20	3 1/8	2 5/8
	KCL110	ESER-080S	333 {8458}	45 {1143}	54 {1372}	2300 {1043}	6	21.0	25	3 1/8	2 5/8
	S-GVV 090. 1/4-N(2).M	ESER-100S	223 {5664}	51 {1295}	69 {1753}	3000 {1371}	4	24.0	25	3 1/8	3 1/8
S-GVV 090. 1/5-N(2).M	ESER-120S	271 {6883}	51 {1295}	69 {1753}	3625 {1644}	5	30.0	35	3 1/8	3 1/8	
Dual-circuit	KCM034	ESER-020D	83 {2108}	83 {2108}	48 {1219}	830 {376}	4	4.9	15	1 5/8	1 1/8
	KCL047	ESER-030D	113 {2870}	87 {2210}	54 {1372}	1275 {578}	4	16.0	20	2 1/8	1 3/8
	KCL060	ESER-040D	113 {2870}	87 {2210}	54 {1372}	1525 {692}	4	16.0	20	2 1/8	1 5/8
	KCL074	ESER-050D	113 {2870}	87 {2210}	54 {1372}	1525 {692}	4	16.0	20	2 1/8	1 5/8
	KCL090	ESER-060D	168 {4267}	87 {2210}	54 {1372}	2050 {930}	6	21.0	25	2 5/8	1 5/8
	KCL112	ESER-080D	168 {4267}	87 {2210}	54 {1372}	1175 {533}	6	21.0	25	2 5/8	2 1/8
	KCL137	ESER-100D	223 {5664}	87 {2210}	54 {1372}	2800 {1270}	8	31.0	35	2 5/8	2 1/8
	KCL190	ESER-120D	278 {7061}	87 {2210}	54 {1372}	3700 {1678}	10	36.0	40	3 1/8	2 5/8
	KCL224	ESER-160D	333 {8458}	87 {2210}	54 {1372}	4400 {1996}	12	46.0	50	3 1/8	2 5/8
	S-GVD 090.1D/2 x4-M2.M	ESER-200D	225 {5715}	95 {2413}	112 {2845}	7800 {3538}	8	31.0	35.0	3 1/8 x 2	3 1/8 x 2
S-GVD 090.1D/2 5-M2.M	ESER-240D	275 {6985}	95 {2413}	112 {2845}	10,025 {4547}	10	38.0	40.0	3 5/8 x 2	3 5/8 x 2	

Specification Notes

* One condenser is required per chiller; dual-circuit chillers use one remote condenser that has two refrigeration circuits.
 † MCA is minimum circuit ampacity (for wire sizing). MOP is maximum overcurrent protection, used for sizing main power protection device. Operating weight varies based on system refrigeration charge and operating conditions.
 Operating weight varies based on system refrigerant charge and operating conditions.
 Specifications may change without notice. Check with a Conair representative for the most current information.

