

# Precision Pulling and Cutting for Medical Tubing Products

Conair's extensive experience in medical grade extrusion equipment offers processors a wide selection of precision pulling and cutting equipment for maximizing cleanliness, efficiency and precision.

Choose from small, medium or large, high-speed fly-knife cutters, mounted on precision rails for optimized positioning. And precision pullers, with belts of various sizes or pinch rollers with single or dual drive systems. Each of these selections can be ordered alone, or mounted together on a combined base, integrated with intuitive touch screen controls for the ultimate solution in cutting and pulling efficiency.



**Model MDL1-12S:0.25L**  
(Shown with stainless steel base option and misting system option.)

## Highly efficient microbore tubing production

Start with a movable/lockable stainless steel base cabinet and touchscreen control and add a cutter, a puller or both to provide the best possible production system available for microbore tubing production. Each cutter/puller MedLine package can also be equipped with fully integrated control of downstream take-away tables to keep the product moving and/or upstream feeding roll control for offline cutting operations.

MedLine fly-knife cutters are mounted on stainless steel rails for optimized positioning, assuring smooth, zero-friction tubing entry. Encased in clean, clear, highly visible plexiglass housings, cutters are offered in 0.25, 1.0 and 2.0 maximum tube sizes and are shipped complete with sized bushings for your tubing product. Up to 350 cuts per minute can be achieved with a precision, servo motor drive system.

Pullers are offered in belt models up to 3-inch {76.2 mm} wide and 20-inch {508 mm} long or advanced pinch rollers for high speed, minimal contact applications. Single or dual servo motors are supplied for highly controlled, precision pulling control.

### ▶ Precise pulling with servo motors

Independent servo motors with precision, inline, planetary gear reducers provide consistent, repeatable pulling with optimum torque and minimum drive system backlash.

### ▶ Eliminate belt slippage

The helical offset tooth design and self-tracking belts on the 1-12 puller provide a highly accurate and efficient puller drive system.

### ▶ Visible processing

All pinch rolls and cutters, as well as the 1-12 puller and the 2-12 puller, are equipped with 0.25 inch {6.4 mm} thick polycarbonate window guards that ease the string-up procedure by allowing the user to visually follow the microbore tubing through the pulling and cutting processes.

### ▶ Cutting capacity up to 2.0 inches

The 0.25L cutter can handle extrudates of up to 0.25 inches {6.4 mm} in diameter. Optional 1 inch {25 mm} or 2.0 inch {51 mm} cut capacities are available with the larger cutter models.

### ▶ Touchscreen control

The intuitive, 8-inch, chemical resistant digital operator control provides a user-friendly method to communicate with the Conair Combination Puller/Cutter. Optional 10-inch dedicated program screens for taper/bump/bubble tubing ease the setup process. An optional 15-inch control is also available.



## Features

01

### Simple conveyor setup

Cutting from above the conveyor improves discharge interface.

02

### Visible cutter head

Clear knife guard lets you view the rotating cutter head and blade(s) during operation. Designed for easy access!

03

### Built-in stainless steel particulate/overflow tray

Collects waste lubricant and material with each pass of the cutter blades. A fitting is provided for ease of draining.

04

### Stainless steel cabinet

An optional stainless steel cabinet is available for medical applications.

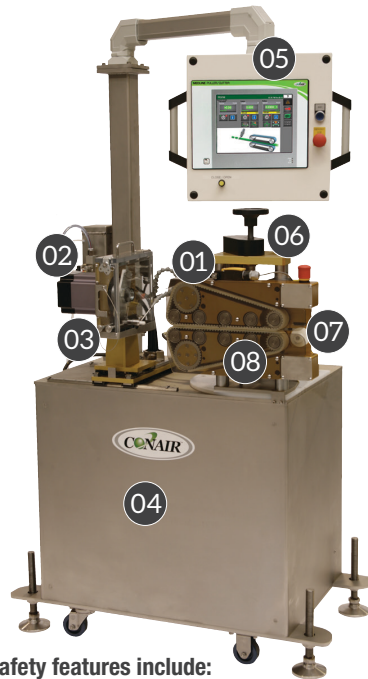

### Safety features include:

- Easy-to-reach emergency stop buttons\*
- Polycarbonate knife guard
- Upper and lower clear polycarbonate belt guards
- Heavy-duty lockdown screws

\* The MedLine models include two independent emergency shutdown switches that, once pressed, will disconnect power to the entire unit and must be reset to restart the puller/cutter.

05

### Optimum eye-level monitoring

Controls are at eye-level and within easy reach.

06

### Precisely control belt tension

Adjust puller belts and control tension on your material by opening or closing the belts with an easy turn or servo boom. Wheel or servo control. Digital belt gap sensor also available.

07

### Centered, guided material

An adjustable roller guides material onto the puller belts.

08

### Precise pulling

Opposing belts uniformly draw material through to the cutter.

## Puller Features / Options

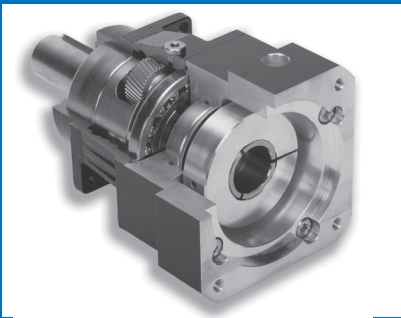

Keep your process running smooth with independent precision planetary gearhead reducers. The MedLine pullers feature helical gearing and gear tooth microgeometry reducers that allow you to produce flaw-free product.

\* Optional on heavy duty models only.

**Independent servo puller motors**  
with low backlash planetary gearheads.

### Remote belt speed control option

*Exclusive* remote control digital potentiometer eases start-up by allowing you to conveniently adjust your belt puller speed while making extruder adjustments. You can dial in your precise speed with the 36 position rotary control knob; virtually eliminating variations due to voltage/noise fluctuations associated with analog controls.

### Digital belt gap sensor and readout option

Allows you to set and measure belt gap, to three decimal places, for consistent belt traction.

### Choice of in-line planetary gear reducer ratios

Reducer ratios can be selected to optimize puller performance based on your application.

### Optional intuitive taper/bump/bubble software.

A digital, positional control is added to the puller servo drive along with a programmable controller (PLC) enabling you to program up to 32 speed variations and 32 analog air pressure adjustments that can be stored for repeatable tube profiling. This combination of air pressure and speed control allow you to produce a high quality, consistent end-product.

**3 inch {76 mm}, 4 inch {102 mm}, or 6 inch {152 mm} dual servo driven pinch rolls.**

## Configuration and Naming

The MedLine Puller/Cutter Series can be configured in many different ways to suit your application perfectly. All MedLine Puller/Cutter models have the same cabinet design. The MedLine can be a medical application puller/cutter combination, a medical puller, or a medical cutter.

The model name/number is determined by the configuration that is desired.

### Pulling information

The first digit in the model name following the MDL (MedLine) distinguishes the difference between a belt puller and a pinch roll.

If the first digit is a number, the number represents the width of the puller belt. The second number represents the length of the belt.

If the third digit is the letter R, the puller utilizes a pinch roll puller. The first and second digits represent the pinch roll diameter and width, respectively.

If the unit is a cutter-only MedLine, this first number will be 0-00.

Single or Dual Servo pulling. This spot in the model will be S for single servo pullers, and D for dual servo pullers.

The colon in the model name separates the puller information and the cutter information.

### Cutting information

The second number represents the diameter capacity of the cutter. If the unit is a puller only MedLine, this second number will be 0.00.

Light or Heavy Duty. An L will appear in this space if this is a light-weight model. The H will appear if this is Heavy Duty.

**MDL**  -     :

For example, a MDL1-12S:0.25 is a MedLine that has a puller with 1 inch wide belt, 12 inches long, driven by a single servo. It has a cutter capable of cutting 0.25 inch diameter material.

A MDL6-3RD:0.00 is a MedLine that has a pinch roll 6 inches in diameter, 3 inches wide, driven by dual servos. It has a no cutting head.

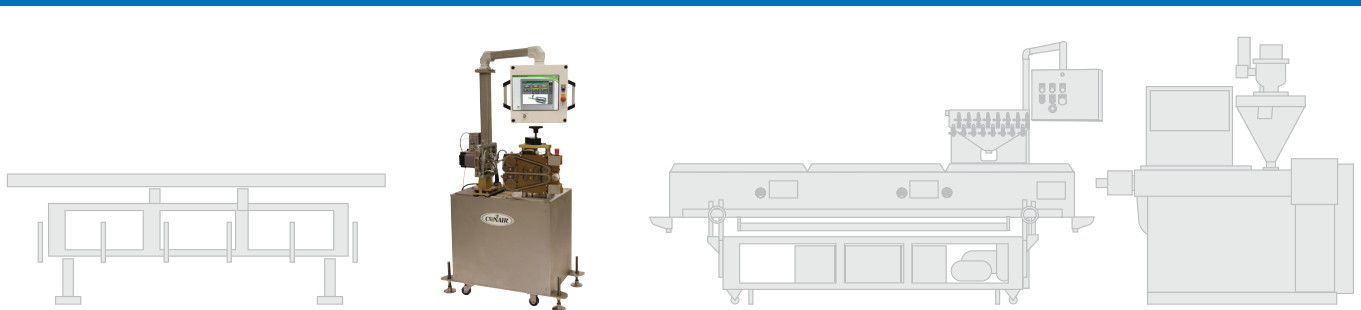

The MedLine Puller/Cutter is used in-line, downstream from the extruder and tank, to pull, cut, or pull and cut product which can then be transferred to a Medical Take Away Conveyor or coiled onto a Conair ATC coiler.

# Configuring the Right MedLine for you

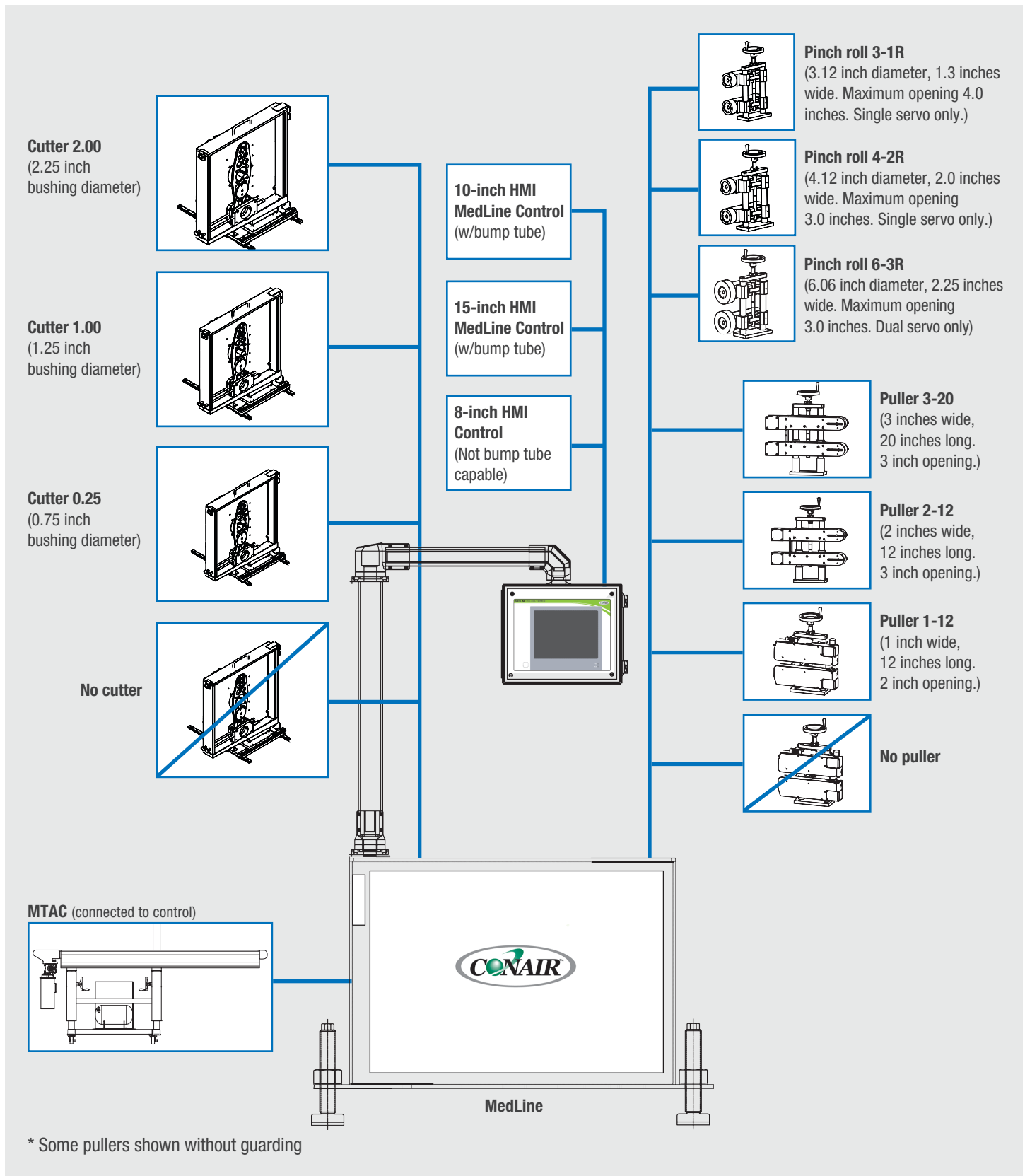

## Control



The MedLine Puller/Cutter touchscreen control, available in standard 8-inch or optional 10, or 15-inch models, provides a graphical interface designed for easy navigation by even novice operators through clear multi-lingual icons and actions optimized for commonly requested functions. Two software selections are offered to match processing and final product needs:

- Standard software accommodates all straight tubing applications and about 85% of common taper tube applications, and features easy to use controls, with all set-up data included on a single page.
- Optional software is offered for more complex, multi-step, taper tubing applications and features sophisticated, yet easy to understand adjustments for pulling and cutting coordinated programming. A Conair exclusive.

Regardless of software choice, each includes easily changed cutting modes, adjustment of blade speed, up to three quality control settings, recipe storage, control of a takeaway conveyor, multiple levels of security and communication with other devices. All Conair controls are designed in a common, friendly, international style, making learning a new piece of equipment easy and comfortable.

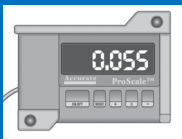

### Digital Belt Gap Sensor

This option allows you to set the zero point for the belt gap, and then set and measure belt gap to three decimal places.

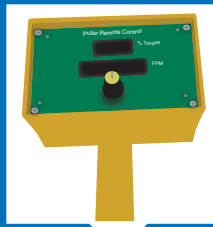

### Digital Remote Control

This optional control allows the puller's speed to be fine-tuned from down the line to 36 programmable settings.

## Options

- 10-inch HMI screen
- Stainless steel cabinet
- Left-to-right puller motion
- Variable blade speed in both demand and flywheel cutting modes
- Bushing lubrication system
- Scrap mode
- 2-inch cut capacity
- Bushing sizes to 2.25 inch {57mm}
- Multiple length and batch counts
- Follower cutting mode
- Digital belt gap sensor
- Tapered/bubble control tube / profile software
- Gauging interface
- Optional package for multi-lumen control
- Two 120 Volt ACC auxiliary outlets with maximum 12 amps
- Pinch roll puller units
- Stainless steel blank cutter bushings
- CE certification
- UL certification

## Dimensional Specifications

Models	MedLine*			
<b>Performance characteristics</b>				
Extrudate capacity inches {mm} dia.	0.25 - 2.00 {6.4 - 50.8}			
Blade drive motor (3000 rpm) cutter Hp {kW}	3.25 - 4.4 {2.4 - 3.3}			
Servo puller drive motor Hp {kW}	1.5 - 2.0 {1.2 - 1.5}			
<b>Dimensions inches {mm}</b>				
A - Height	71.0 {1803.4}			
B - Height to centerline, ±2 {±50.8}	42.0 {1067.0}			
C - Width	40.0 {1016.0}			
D - Depth	27.0 - 36.0 {685.8 - 914.4}			
Belt width ±3/8 {±9.5}	1.0 - 3.0 {25.4 - 76.2}			
Belt traction length	12.0 - 20.0 {304.8 - 508.0}			
<b>Reducer ratio/belt speed</b>				
Available speeds <sup>†</sup> ft/min	1.4 to 140	2.5 to 250	5.5 to 550	10 to 700
<b>Weight lb {kg}</b>				
Installed	715.0 - 790.0 {324.0 - 358.4}			
Shipping	700.0 - 800.0 {317.5 - 363.0}			
<b>Voltage Full load amps<sup>‡</sup></b>				
460V/3 phase/60Hz	Consult Conair			
<b>HMI control</b>	Touchscreen			

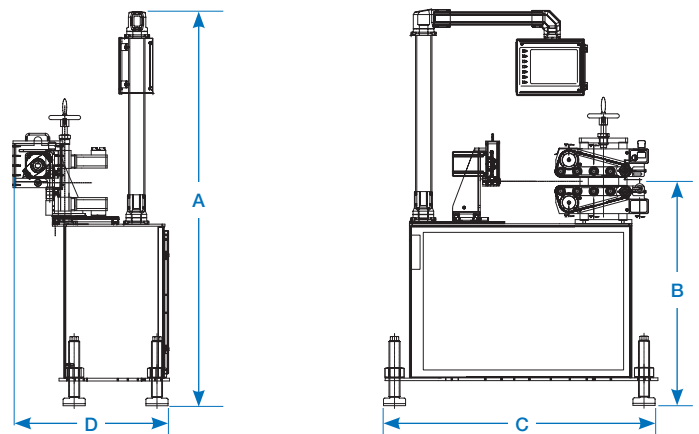

### Specification Notes

\* Specifications will vary based upon configuration selected. See the next page for specifications for individual components.

<sup>†</sup> Examples of possible speeds are shown. Belt speeds will vary depending on drive type (single or dual).

<sup>‡</sup> FLA data for reference purposes only. Does not include any options or accessories on equipment. For full FLA detail for power circuit design of specific machines and systems, refer to the electrical diagrams of the equipment order and the nameplate applied to the machine.

Specifications may change without notice. Consult with a Conair representative for the most current information.



## Pulling Component Specification

Pinch Roll Puller Models	3-1	4-2	6-3
<b>Performance characteristics</b>			
Roller width inches {mm}	1.30 {33}	2.00 {51}	2.26 {57}
Roller diameter inches {mm}	3.20 {81}	4.12 {105}	6.06 {154}
Feed opening inches {mm}	4 {102}	3 {76}	3 {76}
Drive type	servo (single)	servo (single)	servo (dual)
Roller drive motor Hp {kW}	2 {1.5}	2 {1.5}	3.25 {2.4}
Roller speed* ft/min {m/min}	up to 250 {76}	up to 500 {152}	up to 1200 {366}

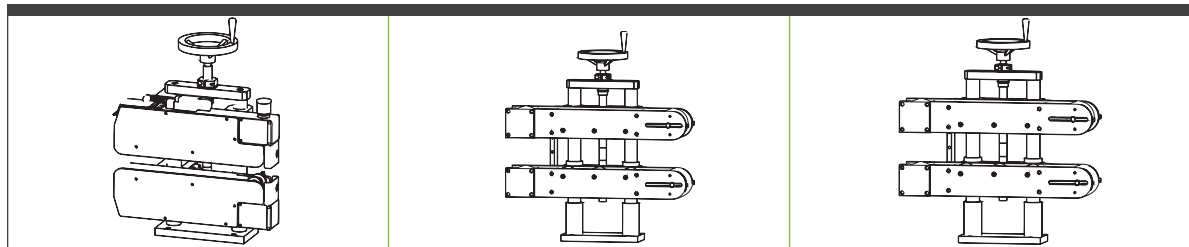
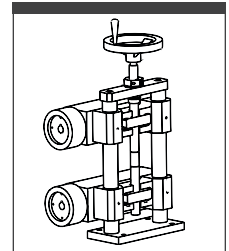

Belt Puller Models	1-12	2-12	3-20
<b>Performance characteristics</b>			
Belt width inches {mm}	1.0 {25.4}	2.00 {51}	3.0 {76}
Belt traction length inches {mm}	12.0 {305}	12.0 {305}	20.0 {508.0}
Feed opening inches {mm}	2.0 {50.8}	3.0 {76}	4.0 {102}
Drive type	servo (single or dual)		servo (single)
Belt drive motor Hp {kW}	(2) 1.0 Hp {0.75 kW}	(2) 2.0 Hp {1.5 kW}	
Belt speed ranges* ft/min {m/min}	1.4 - 140 {36 - 3600}	1.4 - 150 {36 - 3810}	
		2.5 - 250 {64 - 6350}	
		5.5 - 550 {140 - 13970}	
	10 - 750 {254 - 19050}	10 - 700 {254 - 17780}	

## Cutting Component Specifications

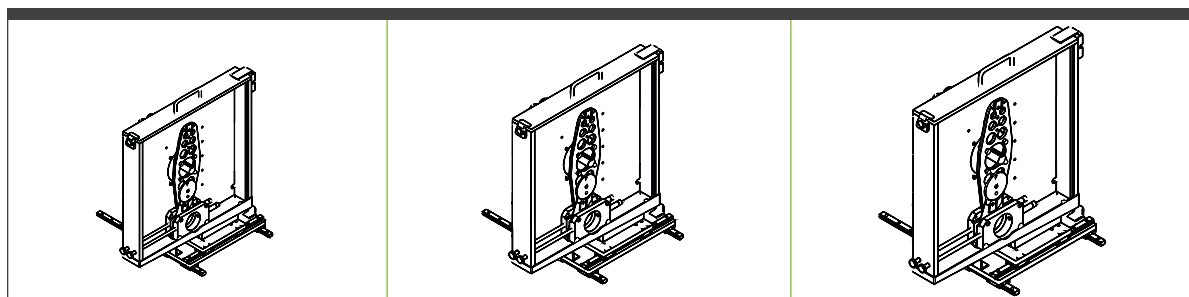

Cutter Models	0.25L	1.00L	2.0L	2.0H
<b>Performance characteristics</b>				
Extrudate capacity inches {mm} diameter	0.25 {6.35}	1.00 {25.4}†	2.00 {50.8}†	2.00 {50.8}
Bushing inches {mm} diameter	0.75	1.25	2.25	2.25
Blade drive motor Hp {kW}	3.25 {2.4}	3.25 {2.4}	4.4 {3.3}	4.4 {3.3}
High torque motor†	N/A	4.4 {3.3}	STD	STD
Feed direction	right-to-left	right-to-left	right-to-left	right-to-left
<b>Cutter head</b>				
Aluminum 2-position	Yes	Yes	NA	NA
Stainless steel 2-position†	NA	Yes	STD	STD
Roller speed* ft/min {m/min}	Yes‡	Yes‡	Yes‡	Yes‡

### Specification Notes

\* Examples of possible speeds are shown. Belt speeds will vary depending on drive type (single or dual).

† Dependent on material and wall thickness.

‡ Optional.

Specifications may change without notice. Consult with a Conair representative for the most current information.

