

Versatile Control For Vacuum Conveying

The Easy Loading Control (ELC) from Conair offers a simple-to-use interface for your conveying system.

With the ELC, loading parameter setup can be accomplished with a few simple steps. Available with two application specific models, the ELC is capable of handling all your conveying needs.



ELC-16 Control

Simple-to-Use Pendant for Conveying Control

The ELC is available as two models; the ELC-M and the ELC-16. The ELC-M is used for stand-alone hopper loader applications. The ELC-16 uses a CAN open network that allows up to 16 controls with receivers on one network cable, operated by a pump controller.

The ELC's optional ControlMate™ pendant uses the same type of intuitive interface as the ELC control, but allows the capability to change a total of 16 preset parameters to fine-tune your conveying needs. The ControlMate pendant can be used interchangeably with either the ELC-M or ELC-16 controls.

The ELC will ship mounted and connected to your loader or receiver when purchased from Conair. Installation of your loader or receiver with the ELC is as simple as bolting it to your material vessel and connecting your power and/or communication cables.

▶ Easy-to-read display

Both the ELC control module and optional ControlMate™ pendant have clearly visible display panels. Loading sequence symbols and LED indicators display exactly where your loader or receiver is in the conveying process.

▶ First-In/First-Out demand loading

The ELC-16 control module comes standard with First-In/First-Out (FIFO) demand. Unlike earlier loading controls, the ELC-16 does not load receivers based on traditional demand loops. Instead, the receivers are loaded based on the order of demand for material.

▶ Configure for priority receiver demand

Use the optional ControlMate pendant to activate priority demand for your ELC-16 control. This setting creates a second priority demand First-In/First-Out demand loop, that takes priority over the standard First-In/First-Out demand loop.

▶ Interchangeable ControlMate™ pendant

The addition of the optional ControlMate pendant allows the capability to alter up to 16 loading parameters for even more functionality. All loading changes are saved within the standard ELC module, so one ControlMate can be used with multiple ELC controls.



Control Models



ELC-16 control

A trunk cable supplies power and communications to up to 16 controls mounted on receivers from a central pump control via a CAN open network.

All ELC-16 controls are equipped with easy connections to the cables and junction boxes that make up the CAN open network.



ELC-M control

Used with a self-contained vacuum motor loader. The ELC-M is provided as standard with a three pronged power cable for easy installation.

ControlMate™ Pendant (optional)



ControlMate™ Pendant

The ControlMate pendant expands your loader's capabilities while providing convenient remote controls for your Access Loader. The ControlMate includes a 15 foot connection cable and handy holster.

A helpful graphic and array of LEDs, illustrate expanded loading functions like ratio loading and line purging while a three-digit numeric display shows each functions setting as it is selected.

• Interchangeable programming

One pendant can be moved from one ELC control to another to program advanced settings. The same ControlMate pendant can even be used with Conair's ELC-16 central vacuum controls. **Note:** ControlMate pendants hold no program data, so one pendant can be freely used with the entire family of Conair ELC controls. Data, once programmed with the ControlMate, safely resides in each ELC control.

• Change up to 16 parameters

The additional loading functions available with the ControlMate Pendant include:

- On/Off
- Unload Time
- Load Attempts
- Ratio Layers
- Ratio Percentage
- Purge Time
- Load Time
- Blowback
- Priority Demand
- Fill Sensor Logic
- Demand Sensor Logic
- Fill Sensor Present
- Load and Hold
- Purge / Adjustable Purge Valve (APV)
- Ratio Installed
- Blowback Installed

Note: Some ControlMate functions require additional components for their operation, ie: Ratio valve, purge valve.

ControlMate™ Function

01

Push the Function button  until the appropriate LED indicator is illuminated to change any loading parameter.

02

Use the (+) or (-) buttons located to the left of the Function button to change a loading parameter to your requirements.

03

Once your parameters are changed there is no need for further keys strokes, all parameters are instantly saved to the ELC control.



How it Works

ELC-M control

A signal from the loader's demand switch indicates to the ELC-M on the loader that it requires material to be conveyed to satisfy its demand. The ELC-M sends a signal to the vacuum motor on the loader to energize and start a loading cycle. The material is then drawn in by the loader's vacuum motor. If the hopper is filled, the demand switch will remain open (*Figure 1*) and no further load cycles will be needed. However, if the demand was not satisfied and the demand switch closes (*Figure 2*) the loader will continue with loading cycles until the demand is satisfied.

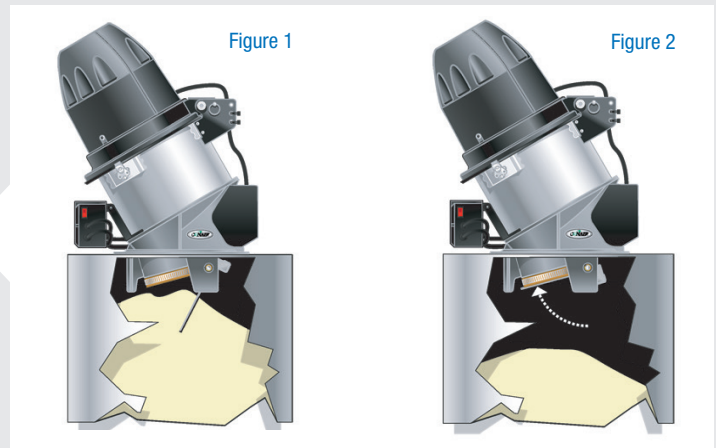

ELC-16 control

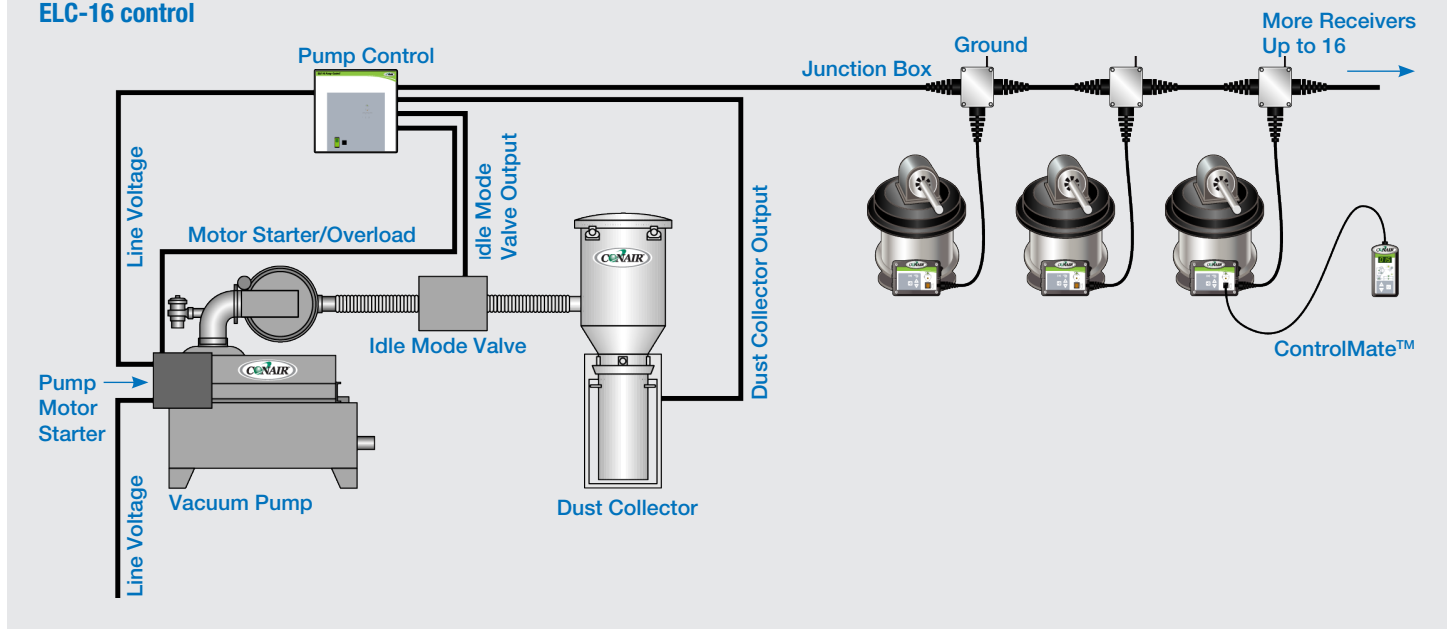

A signal from the receiver's demand switch indicates to the individually mounted ELC-16 on the receiver that it requires material to be conveyed to satisfy its demand. The ELC-16 then communicates its need for material to the pump control via a CAN open network. The demand signal from the ELC is then added to the pump control's queue. The vacuum pump control will then permit the receiver to load on a First-In/First-Out (FIFO) basis.

The ELC-16 control is used for a number of receivers (up to 16) on a CAN open network. The ELC-16 control uses First-In/First-Out (FIFO) for receiver demand. The FIFO setting works within your CAN open network and will allow the receiver that demanded material first to receive it first. For example, if there are four (4) receivers in a series that have demands for material, but the third receiver demanded material first, regardless of the receiver's physical location on the CAN open network, it will be provided with material.



Specifications

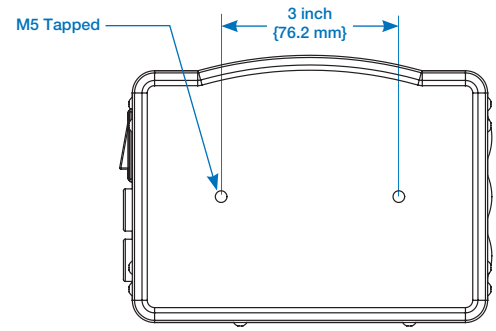
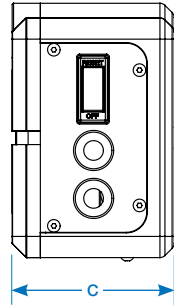
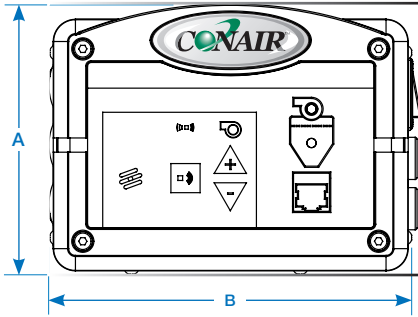

Models	ELC-M	ELC-16
Supply voltage	115VAC 50Hz, 230VAC 50/60Hz	115VAC
Pump control voltage	Full load amps	
230VAC/60Hz	N/A	0.64
400VAC/50Hz	N/A	0.37
460VAC/60Hz	N/A	0.32
Control dimensions	inches {mm}	
A - Height	4.5 {114.4}	
B - Width	6.0 {152.4}	
C - Depth	2.9 {73.0}	
Control weight	lb {kg}	
Installed	7.6 {3.4}	
Shipping	9.1 {4.1}	

Calculating ELC-16 system cable length

Total the distance from the vacuum pump power supply to the last loading station. Account for reasonable slack at each loading station for connections, cable routing, etc. Junction boxes must be provided to connect between the system trunk cable and each ELC-16 control.

Specification Notes

The ELC-16 system trunk cable is two, 4-conductor shielded twisted cables.

* FLA data for reference purposes only. Does not include any options or accessories on equipment. For full FLA detail for power circuit design of specific machines and systems, refer to the electrical diagrams of the equipment order and the nameplate applied to the machine.

Specifications may change without notice. Consult a Conair representative for the most current information.

Optional ControlMate™ Pendant and Cradle

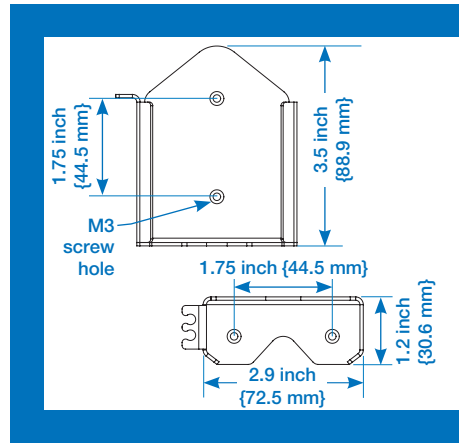
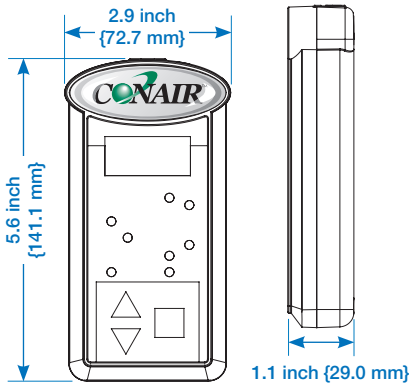

ControlMate™ Pendant Cradle

The ControlMate Pendant is provided with a surface mountable docking cradle for quick and easy retrieval. The cradle can be mounted to any vertical or horizontal surface by using M3 flat-head mounting screws.

A cable clip on the control cradle keeps the ControlMate's communication cable up and out of the way for neat installation. It can also be used for a permanent communication cable location when the ControlMate is being used elsewhere.

Optional ControlMate™ Pendant and Cradle

ELC-16 pump control

The ELC-16 pump control provides power and communications to all the ELC-16 controls within the CAN open network via a 4-conductor trunk cable. The pump control also provides the "start" signal to the vacuum pump used in the conveying process in the ELC-16 system. Cord grips are provided to allow interconnection with the ELC-16 system's trunk cable, dust collector and idle mode valve connections.

The pump control enclosure is equipped with wall mounting accommodations and can be mounted to a flat surface using the supplied mounting holes. The pump control should be located so access to its switches and viewing of its lights are not obstructed.

